

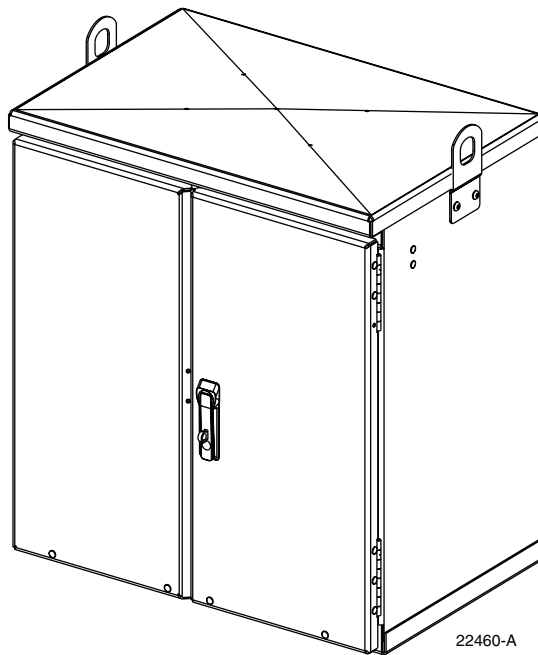

OmniReach[®] FDH 3000 288 Pole-Mount Cabinet

User Manual

ADCP-96-133 • Issue 1 • 04/2008



22460-A

COPYRIGHT

© 2008, ADC Telecommunications, Inc.
All Rights Reserved

REVISION HISTORY

ISSUE	DATE	REASON FOR CHANGE
1	04/2008	Original release

LIST OF CHANGES

The technical changes incorporated into this issue are listed below.

PAGE	IDENTIFIER	DESCRIPTION OF CHANGE
	-	Original release

TRADEMARK INFORMATION

ADC, ADC Telecommunications, and OmniReach are registered trademarks of ADC Telecommunications, Inc.

Telcordia is a registered trademark of Telcordia Technologies, Inc.

GORE is a registered trademark of W. L. Gore & Associates, Inc.

DISCLAIMER OF LIABILITY

Contents herein are current as of the date of publication. ADC reserves the right to change the contents without prior notice. **In no event shall ADC be liable for any damages resulting from loss of data, loss of use, or loss of profits and ADC further disclaims any and all liability for indirect, incidental, special, consequential or other similar damages. This disclaimer of liability applies to all products, publications and services during and after the warranty period.**

This publication may be verified at any time by contacting ADC's Technical Assistance Center at 1-800-366-3891, extension 73475 (in U.S.A. or Canada) or 952-917-3475 (outside U.S.A. and Canada), or by e-mail to connectivity_tac@adc.com.



ADC Telecommunications, Inc.
P.O. Box 1101, Minneapolis, Minnesota 55440-1101
In U.S.A. and Canada: 1-800-366-3891
Outside U.S.A. and Canada: (952) 938-8080
Fax: (952) 917-1717

TABLE OF CONTENTS

Content	Page
ABOUT THIS MANUAL	v
RELATED PUBLICATIONS	v
ADMONISHMENTS	v
GENERAL SAFETY PRECAUTIONS	v
STANDARDS CERTIFICATION	vi
LIST OF ACRONYMS AND ABBREVIATIONS	vi
1 DESCRIPTION	1
1.1 288 Pole-Mount Cabinet	1
2 BEFORE STARTING THE INSTALLATION	5
2.1 Installation Overview	5
2.2 Unpacking and Inspection	5
2.3 Cabinet Installation Hardware	6
2.4 Tools and Materials Required for Installation	6
3 MOUNTING THE POLE-MOUNT CABINET ON A UTILITY POLE	7
3.1 Installation Recommendations	7
3.2 Grounding System Installation	7
3.3 Mounting the Cabinet	7
4 FEEDER AND DISTRIBUTION CABLE CONFIGURATION INFORMATION	11
4.1 OSP Feeder Cable Configuration	11
4.2 OSP Distribution Cable Configuration	12
5 PLUG AND PLAY SPLITTER MODULE INSTALLATION	13
6 ROUTING AND CONNECTING THE SPLITTER OUTPUT FIBERS	16
6.1 Storing The Splitter Output Fibers	16
6.2 Enabling Service To a Subscriber	17
7 PASS-THROUGH ROUTING PROCEDURE	18
7.1 Sliding Adapter Pack Pass-Through Routing Procedure	18
7.2 Splitter Compartment Pass-Through Routing Procedure	20
8 FEEDER CABLE FIBER RE-ROUTING PROCEDURE	22
9 MAINTENANCE AND REPAIR PROCEDURES	25
9.1 Painting	25
9.2 Distribution Panel Adapter Replacement	25
9.3 Splitter Compartment Adapter Replacement	26
9.4 Replacing a Damaged Fiber or Connector	27
9.5 Door Gasket Replacement	28
9.6 Door Replacement	28
10 CUSTOMER INFORMATION AND ASSISTANCE	31

TABLE OF CONTENTS

Content	Page
---------	------

Blank

ABOUT THIS MANUAL

This publication describes the OmniReach FDH 3000 288 Pole-Mount Cabinet. Also included are procedures for mounting the cabinet, installing additional splitter modules, storing the splitter output fibers, connecting the splitter output fibers to the distribution fibers, and replacing damaged components.

RELATED PUBLICATIONS

Listed below are related manuals and their publication numbers. Copies of these publications can be ordered by contacting the ADC Technical Assistance Center at 1-800-366-3891, extension 73475 (in U.S.A. or Canada) or 1-952-917-3475 (outside U.S.A. and Canada).

Title	ADCP Number
Optical Fiber Connector Wet and Dry Cleaning Instructions	90-159
Plug And Play Splitter Installation Guide	96-087

ADMONISHMENTS

Important safety admonishments are used throughout this manual to warn of possible hazards to persons or equipment. An admonishment identifies a possible hazard and then explains what may happen if the hazard is not avoided. The admonishments — in the form of Dangers, Warnings, and Cautions — must be followed at all times. These warnings are flagged by use of the triangular alert icon (seen below) and are listed in descending order of severity of injury or damage and likelihood of occurrence.



Danger: *Danger is used to indicate the presence of a hazard that **will** cause severe personal injury, death, or substantial property damage if the hazard is not avoided.*



Warning: *Warning is used to indicate the presence of a hazard that **can** cause severe personal injury, death, or substantial property damage if the hazard is not avoided.*



Caution: *Caution is used to indicate the presence of a hazard that **will** or **can** cause minor personal injury or property damage if the hazard is not avoided.*

GENERAL SAFETY PRECAUTIONS



Warning: *Wet conditions increase the potential for receiving an electrical shock when installing or using electrically-powered equipment. To prevent electrical shock, never install or use electrical equipment in a wet location or during a lightning storm.*



Danger: *Do not look into the ends of any optical fiber. Exposure to laser radiation may result. Do not assume the laser power is turned-off or that the fiber is disconnected at the other end.*



Danger: *Use adequate lifting equipment when moving or installing Fiber Distribution Hub cabinets. Verify that the maximum lift weight rating of the equipment is sufficient to handle the weight of the cabinet.*



Danger: *Do not stand under a Fiber Distribution Hub cabinet as it is being hoisted into position for mounting. A failure of the lifting equipment or apparatus could result in serious personal injury and cause significant damage to the cabinet.*



Warning: *Before digging, check with all local utilities for the presence of buried cables or pipes. Contact with underground cables or pipes, especially electric power cables and gas service lines, could interrupt local utility service and cause serious personal injury and extensive property damage.*

STANDARDS CERTIFICATION

Telcordia: This equipment complies with the applicable sections of GR-3125-CORE.

LIST OF ACRONYMS AND ABBREVIATIONS

The acronyms and abbreviations used in this manual are detailed in the following list:

AWG	American Wire Gauge
C	Centigrade
F	Fahrenheit
FDH	Fiber Distribution Hub
FMS	Fiberglass Mounting Sleeve
FTTP	Fiber To The Premises
OSP	Outside Plant
PMF	Pad Mount Frame
PNP	Plug and Play

1 DESCRIPTION

This section provides a description of the OmniReach FDH 3000 288 pole-mount cabinet plus the cabinet specifications.

1.1 288 Pole-Mount Cabinet

The 288 pole-mount cabinet is a secure, above-ground, outdoor fiber optic distribution cabinet that is designed to hold the various optical components required for Fiber To The Premises (FTTP) distribution network applications. Designed for mounting on a utility pole, a typical 288 pole-mount cabinet is shown in [Figure 1](#).

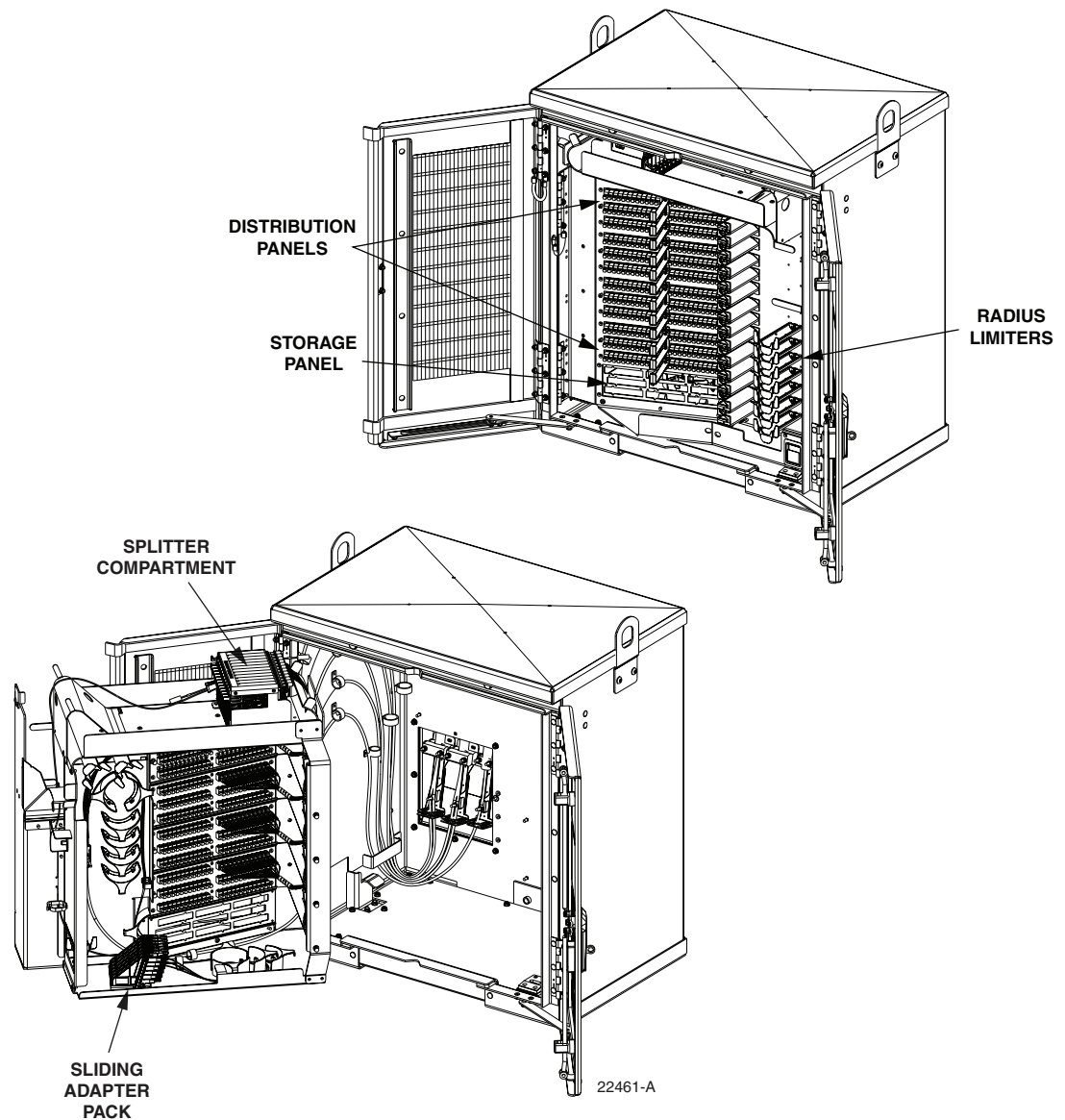

Figure 1. Typical 288 Pole-Mount Cabinet

The interior of the 288 pole-mount cabinet consists the following primary components:

Distribution Panels: Provide a point for connecting the splitter output fibers with the terminated distribution cable fibers. Each panel provides mounting spaces for 72 bulkhead adapters. Adapters for either UPC/SC or APC/SC style connectors are available.

Storage Panel: Provides a temporary “parking lot” for unused splitter output fibers. Each splitter module comes with a connector pack that mounts in the storage panel. Up to nine 8-position connector packs (72 fibers total) can be mounted in the storage panel.

Radius Limiters: Provide a place for storing excess slack from the splitter output fibers.

Splitter Compartment: Provides a place for mounting up to twelve splitters. Unused splitter slots can be used for pass-through fibers. The splitters specified for use with the 288 pole-mount cabinet are equipped with bend-optimized fibers.

Sliding Adapter Pack – Provides a place for terminating up to 36 spare feeder cable fibers. Spare feeder cable fibers may be used as replacements for broken fibers or for signal pass-through functions.

Grounding Studs – Provide a point for connecting a grounding wire to the exterior (rear side) of the cabinet. A 2-hole compression lug for #6 AWG copper cable and the required fasteners are provided.

The exterior shell of the cabinet is constructed of heavy gauge aluminum and is coated with an almond-colored finish. Each cabinet is equipped with two front doors that provide full front access to the optical components. The cabinet doors are equipped with a tamper-resistant latch that includes a hasp for a padlock, stainless steel hinges, and door catches that prevent accidental closing. Access to the cabinet requires a 216B key tool (accessory) to release the latch handle. Lifting eyes are provided for hoisting the cabinet into position for mounting.

The feeder and distribution cables enter/exit the cabinet from the back. A clamp secures each cable to the inside of the cabinet and a compression fitting secures the cable to the outside of the cabinet. The compression fitting also prevents dirt and moisture from entering the cabinet at the cable entry/exit point. Heat shrink sleeving is installed over the compression fittings for additional environmental protection. GORE membrane vents are provided to release any moisture that may accumulate within the cabinet.

The cabinet is designed for pole-mounting only. Mounting brackets for securing the cabinet to a wooden utility pole are included. The mounting brackets attach to the rear side of the cabinet. The fasteners for securing the brackets to the pole must be provided by the installer.

The cabinet is equipped with factory-installed outside plant (OSP) distribution and feeder cables. Ribbon and stranded type cables with dielectric construction are available. The cable stubs are 100 feet in length. An accessory kit is available (FD3-ACCPLCBLDWN) if downward routing of the cables is required. The specifications for the 288 pole-mount cabinet are provided in [Table 1](#).

Table 1. 288 Pole-Mount Cabinet Specifications

PARAMETER	SPECIFICATION
Cabinet	
Dimensions (H x W x D) (See Figure 2)	30 x 26.9 x 20.8 x inches (99.3 x 68.3 x 52.8 cm)
Weight (fully loaded)	80 lbs (36.3 kg)
Certification (pending)	GR-3125-CORE
Distribution panels (maximum)	4 (available fully loaded only)
Distribution ports	288 with four 72-port distribution panels
Distribution port adapters/connectors	UPC/SC or APC/SC,
Feeder/Distribution cable length	100 ft.
Splitter compartment splitter capacity	12 splitters
Splitter compartment adapter capacity	24 adapters
Splitter output fiber storage panel capacity	72 connectors
Sliding adapter pack capacity	36 adapters
Splitter Modules	
Splitter module input and output pigtails	Bend-optimized fiber terminated with UPC/SC or APC/SC connectors
Test bandpass	1260–1360 nm, 1480–1500 nm, 1550–1560 nm
Overall bandpass	1260–1625 nm
Return loss at test bandpass	≥55 dB
Maximum insertion loss at test bandpass	Note: Specification includes the loss from the input and output connectors
1 x 2	4.1 dB with UPC, 4.3 with APC
1 x 4	7.6 dB with UPC, 7.8 dB with APC
1 x 8	10.7 dB with UPC, 10.9 dB with APC
1 x 16	13.9 dB with UPC, 14.1 dB with APC
1 x 32	17.1 dB with UPC, 17.3 dB with APC
1 x 64	20.8 dB with UPS, 21 dB with APC
2 x 16	14.5 dB with UPC, 14.7 dB with APC
2 x 32	17.8 dB with UPC, 18 with APC

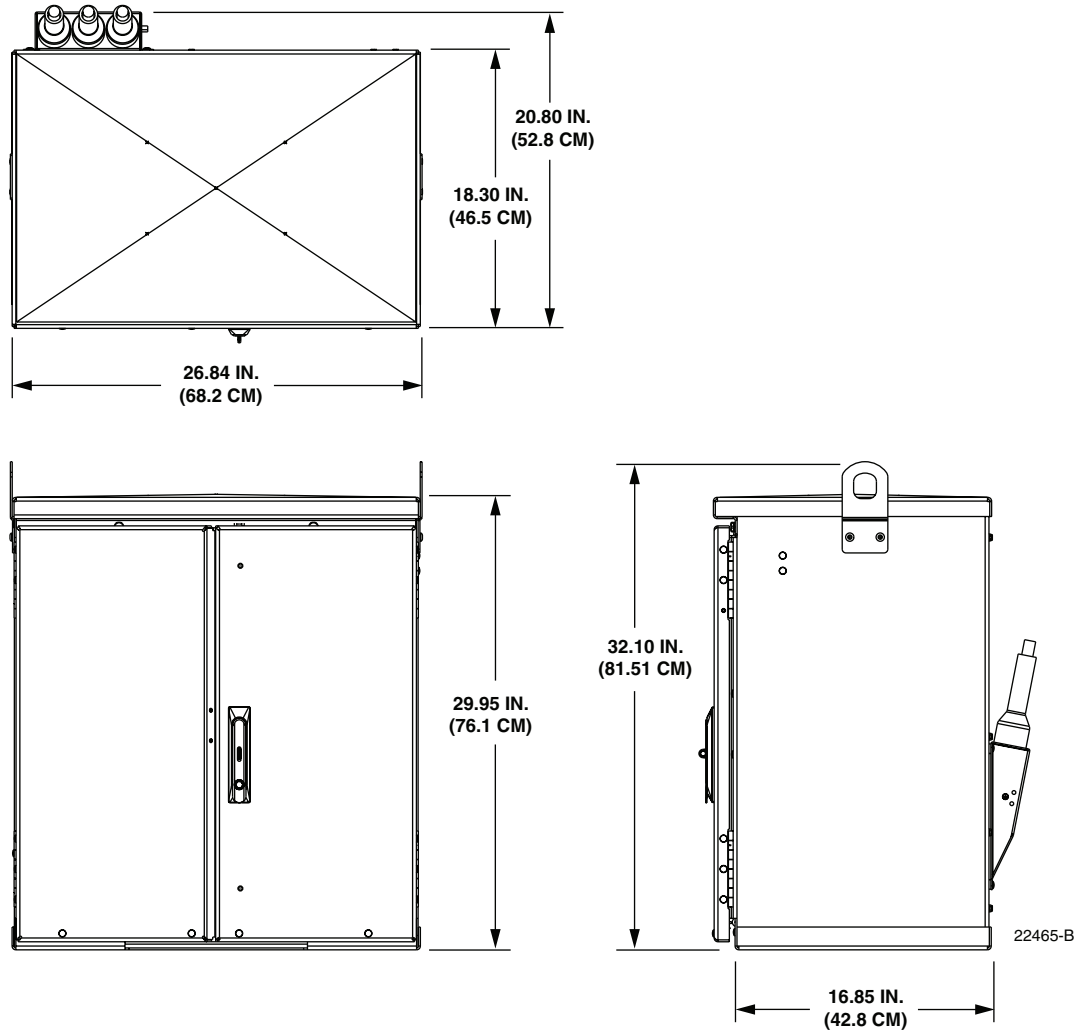

Figure 2. 288 Pole-Mount Cabinet Dimensions

2 BEFORE STARTING THE INSTALLATION

This section provides general installation considerations, unpacking and inspection procedures, and lists the tools and materials required for installing the 288 pole-mount cabinet.

2.1 Installation Overview

Installation of the cabinet involves the following main tasks:

Mounting the Cabinet – The cabinet must be secured to a utility pole. Mounting brackets (without the fasteners) are provided with the cabinet. The OSP feeder and distribution cables must be uncoiled and routed to a separate splice enclosure (not provided) after the cabinet is mounted.

Splitter Installation – The cabinet may be ordered with no splitters installed or with one or two splitters installed. If additional splitters are required, they must be ordered separately. All splitter modules that are ordered separately must be installed in the splitter compartment.

Splitter Output Fiber Connections – Service is provided by connecting the splitter output fiber connectors to the subscriber distribution ports. Unused output fibers are temporarily “parked” in the storage panel until they are needed for service.

2.2 Unpacking and Inspection

This section provides instructions for opening the shipping boxes, verifying that all parts have been received, and verifying that no shipping damage has occurred.

Use the following procedure to unpack and inspect the cabinet and all accessories:

1. Open the shipping carton(s) and carefully unpack the cabinet and any accessories from the protective packing material.
2. Open the cabinet doors (requires 216B key tool) and check for missing ship-along parts (see installation drawing included with cabinet) or broken parts. If there are damages, contact ADC (see [Section 10](#)) for an RMA (Return Material Authorization) and to reorder if replacement is required.

2.3 Cabinet Installation Hardware

The cabinet is shipped with various hardware parts (see [Table 2](#)) for securing the cabinet to a wooden utility pole. Verify that the parts specified are received.

Table 2. Cabinet Installation Hardware

ITEM	QUANTITY
Top bracket (ship-along)	1
Lower bracket (ship-along)	1
Backer plate (installed)	1
Clip plate (installed)	1

2.4 Tools and Materials Required for Installation

The following tools and materials are required for cabinet installation:

- Hammer
- Wire cutter
- Utility knife
- Screwdriver (flat blade)
- Tape measure
- Pen or marker
- 216B key tool (accessory - required to open cabinet door)
- Padlock (optional)
- Splicing equipment for splicing OSP feeder and distribution cables
- Lifting equipment for hoisting the cabinet into position for mounting
- 5/8- or 3/4-inch through-bolt/threaded-rod (1) with nut(s) and washer(s)
- Grounding system, copper wire, and grounding clamp (per local requirements)
- Compression lug crimper (for 2-hole compression lug)
- Power drill
- 1/2 x 3-1/2-inch lag screws (2) and 1/2-inch flat washers (2)
- Wood boring bit (5/8- or 3/4-inch) to drill holes for through-bolt/threaded-rod
- 3/8-inch drill bit to drill holes for 1/2-inch lag screws
- Appropriately sized wrenches for through-bolt/threaded-rod nut(s) and lag screws
- Conduit for OSP feeder and distribution cables (optional)
- Fasteners and hardware to secure conduit to pole (optional)

3 MOUNTING THE POLE-MOUNT CABINET ON A UTILITY POLE

The 288 pole-mount cabinet is specifically designed for mounting on a utility pole. A pole-mount bracket kit is provided with the cabinet.

3.1 Installation Recommendations

The site chosen for the installation must conform to all local codes and any permits required must be obtained prior to the start of installation. The location must be accessible and provide adequate parking for worker and vehicle safety.

The installed cabinet must not create a visual or physical obstruction to vehicular or pedestrian traffic or block pole-climbing access. Ensure that there is sufficient space on all sides to facilitate cabinet installation. The cabinet mounting brackets must be secured to the utility pole with through-bolts/threaded rods and lag screws (not provided).

The cabinet OSP distribution and feeder cables must be routed to a splice enclosure. If necessary, the cables may be protected by installing conduit between the cabinet and splice enclosure. The cabinet is equipped with a 12-, 24-, or 48-fiber feeder cable and either one 288-fiber distribution cable or two 144-fiber distribution cables.

3.2 Grounding System Installation

Install a grounding system (not provided) that meets all local electrical codes. Check local codes for ground system installation, use of clamps, wire size, and any other grounding requirements. Typically, #6 AWG solid copper wire is used for the grounding wire. Install the grounding system near the base of the utility pole for the ground wire connection. Leave sufficient slack in the grounding wire to allow it to be routed up the pole and connected to the cabinet.

3.3 Mounting the Cabinet

Use the 216B key tool to un-latch and open the cabinet door as needed during the mounting process. Use the following procedure to mount the cabinet on a utility pole:



Warning: Use appropriate lifting equipment when moving or installing the cabinet. Do not stand under the cabinet as it is being hoisted into position for installation. A failure of the lifting equipment could result in serious personal injury.

1. Locate where the cabinet will be mounted on the utility pole and place the top bracket in position for mounting as shown in [Figure 3](#).
2. Mark the location of the top bracket mounting hole on the pole.
3. Drill a 5/8- or 3/4-inch hole (equal to diameter of the through-bolt or threaded rod) into the pole at the point marked in step 2.

► **Note:** When the cabinet is mounted, the top of the cabinet will be 7.35 inches (18.7 cm) above the hole for the through-bolt.

4. Secure the top bracket to the pole using a through-bolt or threaded rod, flat washer(s), locking washer(s), and nut(s). Tighten nut(s) securely.

► **Note:** The fasteners specified in step 4 are not included with the cabinet and must be provided by the installer.

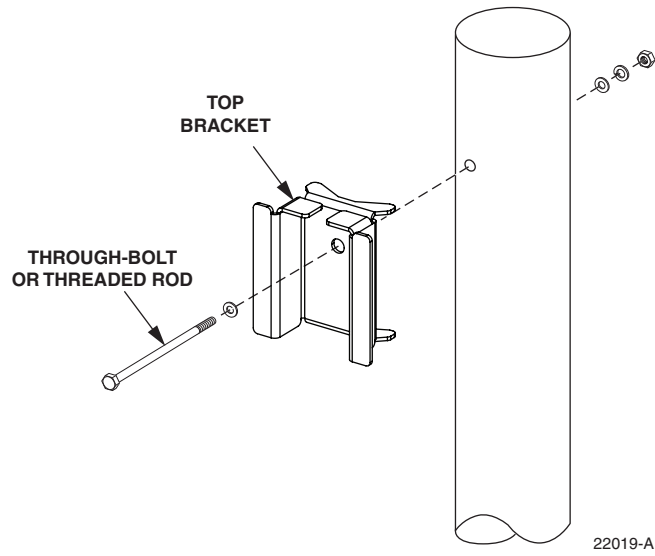

Figure 3. Securing The Cabinet Top Bracket To The Utility Pole

5. Locate the two bottom bracket mounting cap screws (shown in [Figure 4](#)) and the 7/32-inch hex key that are provided with the cabinet.

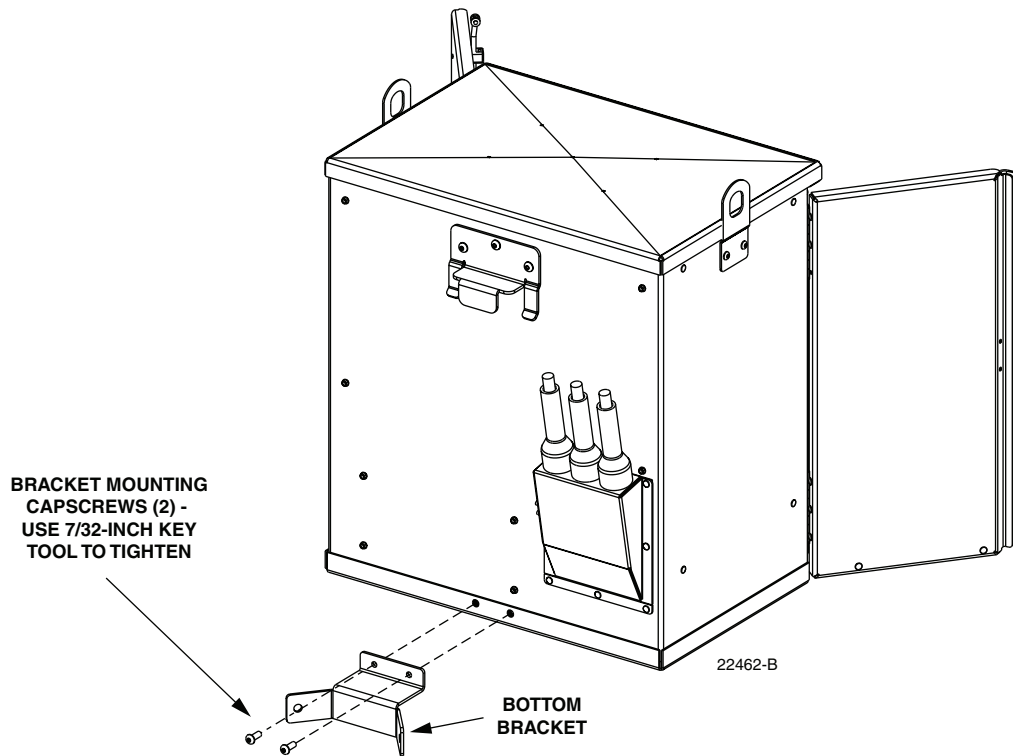

Figure 4. Securing Bottom Mounting Bracket to the Cabinet

6. Use two capscrews to secure the bottom bracket to the cabinet in the specified mounting location. Tighten each capscrew securely.
7. Using appropriate lifting equipment, hoist the cabinet into position for attachment to the utility pole.
8. Hang the cabinet from the installed top bracket as shown in [Figure 5](#). The clip plate on the back of the cabinet slips over the installed top bracket.

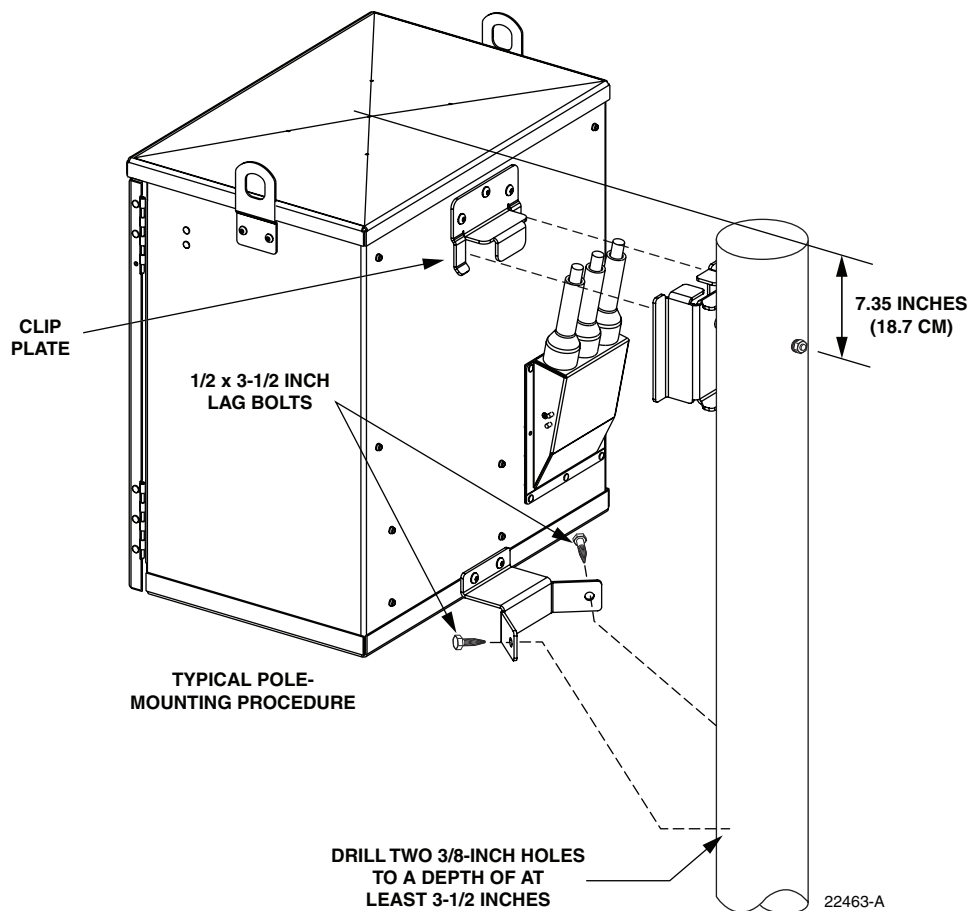

Figure 5. Mounting Cabinet on Pole

9. Check the cabinet to make sure it is level and adjust as needed.
 10. Using the bottom bracket as a template, drill two 3/8-inch holes into the pole to a depth of at least 3-1/2 inches (see [Figure 5](#)).
 11. Secure the bottom bracket to the utility pole using two 1/2 x 3-1/2-inch lag screws and two 1/2-inch flat washers. Tighten lag screws securely.
- **Note:** The fasteners specified in step 12 are not included with the cabinet and must be provided by the installer.
12. Route the feeder and distribution cables to the network splice enclosure (not provided) and splice to the appropriate network cables per local practice.

13. Route the #6 solid copper ground wire (installed in [Section 3.2](#)) up the pole to the bottom of the cabinet.
14. Remove the 2-hole compression lug, two 1/4-20 nuts, and two 1/4-inch star washers from the grounding studs at the rear of the cabinet as shown in [Figure 6](#).
15. Terminate the ground wire with the 2-hole compression lug removed from the back of the cabinet in Step 14.
16. Reattach the compression lug (with attached #6 AWG wire) to the cabinet using the two nuts and star washers removed in step 14. Tighten to 30 to 35 lbs-force inches (3.4 to 4.0 Nm) of torque.

NOTE: COMPRESSION LUG, 1/4-20 NUTS, AND STAR WASHERS PROVIDED WITH CABINET

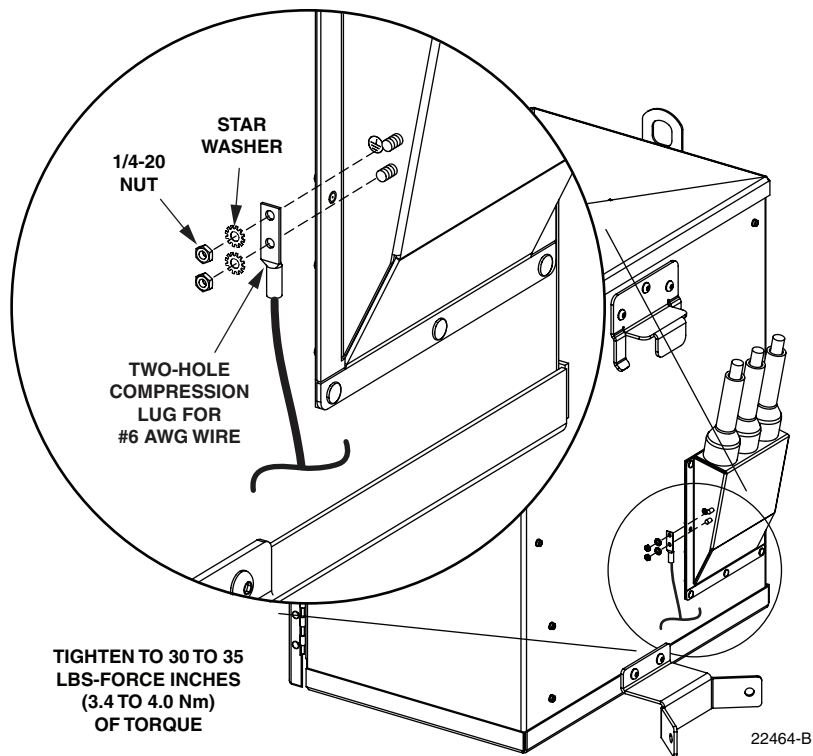

Figure 6. Grounding Cable Connection To Pole-Mount Cabinet

17. Using a 3/16-inch hex key (accessory), remove the screws that secure each lifting eye to the cabinet.
 18. Store the lifting eyes inside the cabinet and then reinstall the lifting eye screws in their original locations on either side of the cabinet.
- **Note:** Remove the lifting eyes to prevent them from being used by service workers as anchor points for safety straps. The lifting eyes are not designed to support the additional weight that could be applied in the event of a fall.

4 FEEDER AND DISTRIBUTION CABLE CONFIGURATION INFORMATION

The 288 pole-mount cabinet is equipped with pre-installed OSP feeder and distribution cables. The cable stub ends must be spliced to the network feeder and distribution cables at a separate splice enclosure (not provided). The feeder and distribution stub cables are 100 feet (30.5 meters) in length. The following sections describe how the cables are configured for splicing.

4.1 OSP Feeder Cable Configuration

The feeder cable may have a fiber count of 12, 24, or 48 fibers depending on the option ordered. Within the cabinet, the outer sheath of the cable is removed to expose the optical fiber subunits. Depending on the option ordered, the cable subunits are routed to the splitter compartment and/or the sliding adapter pack. The subunits are numbered for identification and the individual fibers are color-coded for identification. Always perform a light test before splicing to verify the port location for each fiber. A diagram of the feeder cable routing is shown in [Figure 7](#).

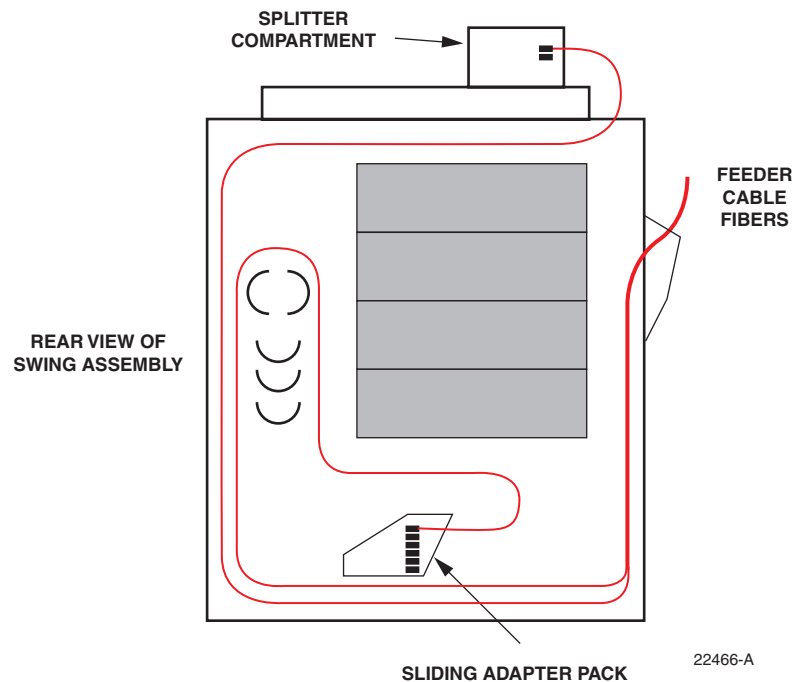

Figure 7. Feeder Cable Typical Configuration

The cabinet may be ordered with no splitters installed or with one or two splitters installed. Up to twelve splitters with either single or dual input ports may be mounted in the cabinet. Designation labels are provided on top of the splitter compartment for recording feeder cable and splitter module information. The splitters specified for use with the cabinet are equipped with bend-optimized fibers.

4.2 OSP Distribution Cable Configuration

Each distribution cable has a fiber count that is a multiple of 72. Either 1 or 2 distribution cables may be present depending on the cable fiber count. Within the cabinet, the outer sheath of each cable is removed to expose the optical fiber subunits. Each subunit is fanned out into 12 individual fibers, each of which is terminated with a connector.

The fiber subunits are routed to the back of each distribution panel. Each fiber connector is connected to a specified bulkhead adapter at the rear of the panel. Depending on the option ordered, the distribution panels may be equipped with either UPC/SC or APC/SC adapters. A diagram of the distribution cable configuration is shown in [Figure 8](#). Distribution cables with 144 or 288 fibers are available.

Designation labels are provided on the cabinet doors for recording subscriber information for each distribution panel port. The labels indicate the fiber number and cable number associated with each fiber port. The subunits are numbered for identification and the individual fibers are color-coded for identification. Always perform a light test before splicing to verify the port location for each fiber.

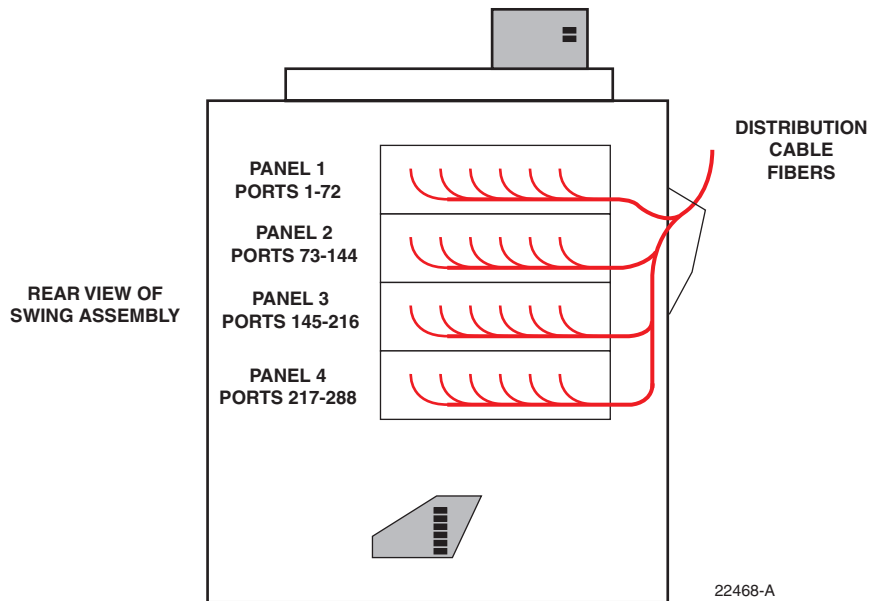

Figure 8. Distribution Cable Configuration

5 PLUG AND PLAY SPLITTER MODULE INSTALLATION

The 288 pole-mount cabinet can accommodate up to twelve splitter modules. Plug and play splitter modules are equipped with either one or two input connectors and up to thirty-two output fibers. The splitter modules insert into slots in the splitter compartment. Inserting a splitter into a slot connects the splitter input connector(s) to the feeder cable connector(s). The splitter output fibers may be either stored for later use or routed to the distribution panels for connection to the distribution ports. Additional instructions for installing plug and play splitter modules are provided in the FDH 3000 Plug and Play Splitter Installation Guide (ADCP-96-087). Use only splitters equipped with bend-optimized fibers.

Use the following procedure to install additional splitters in the cabinet:

1. Locate the next available splitter mounting position as shown in [Figure 9](#).

► **Note:** Install splitters in the order shown, beginning on the left side of the splitter compartment and then working toward the right.

2. Remove the dust cap assembly from the selected splitter slot.

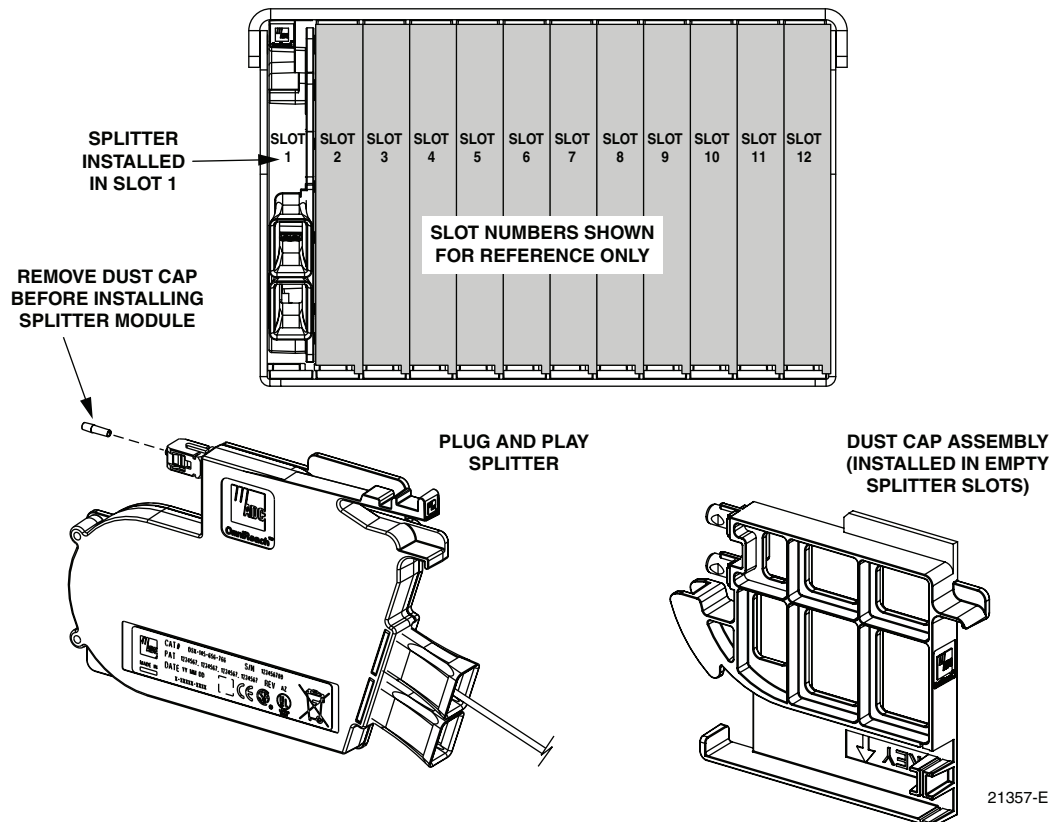

Figure 9. Splitter Module Mounting Slots

3. Remove the corresponding feeder cable connector(s) from the rear of the splitter compartment as shown in [Figure 10](#).



Warning: *Infrared radiation is invisible and can seriously damage the retina of the eye. Do not look into the ends of any optical fiber. Do not look directly into the optical adapters or connectors. Exposure to invisible laser radiation may result. An optical power meter should be used to verify active fibers. A protective cap or hood **MUST** be immediately placed over any radiating adapter or optical connector to avoid the potential of dangerous amounts of radiation exposure. This practice also prevents dirt particles from entering the adapter or connector.*

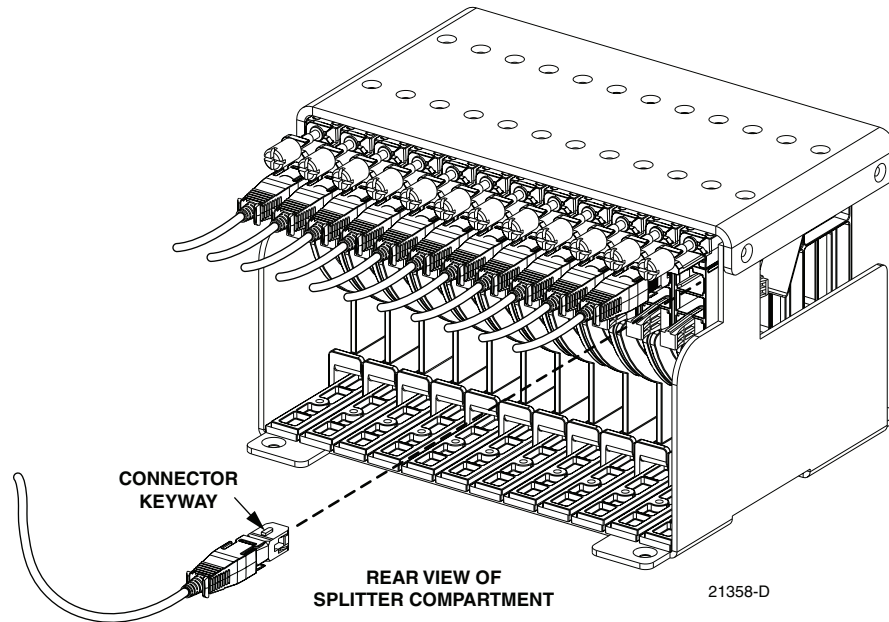

Figure 10. Feeder Cable Connector

4. Clean the feeder cable connector(s) as specified in the Optical Fiber Systems Cleaning and Mating Instructions (ADCP-90-159).
5. Reinstall the feeder cable connector(s) at the rear of the splitter compartment.
6. Remove the dust cap from the splitter connector (see [Figure 9](#)).
7. Insert the splitter into the mounting slot as shown in [Figure 11](#).
8. Route the splitter output fibers to the storage panel or to the designated subscriber port. Refer to [Section 6](#) for the routing procedure.

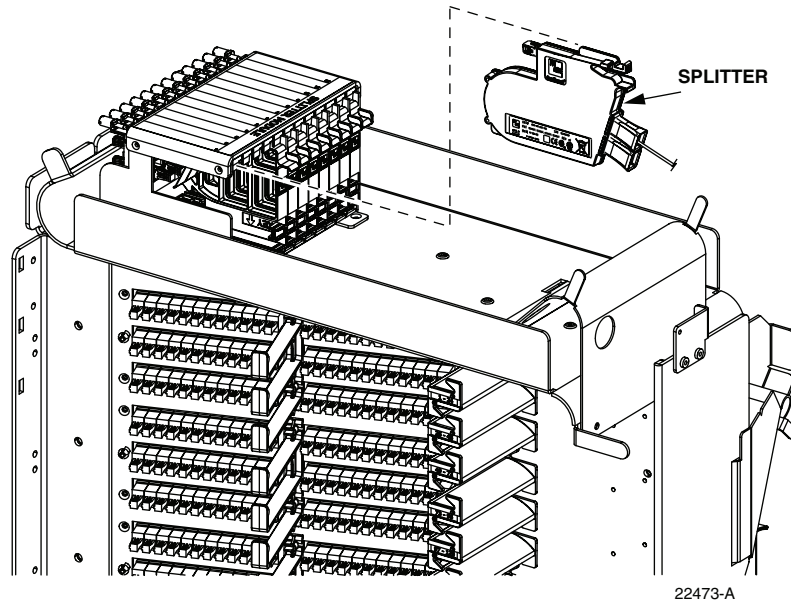

Figure 11. Splitter Installation

6 ROUTING AND CONNECTING THE SPLITTER OUTPUT FIBERS

The splitter modules are mounted at the top of the 288 pole-mount cabinet. When a splitter module is initially installed, the output fibers are routed to the storage panel located at the bottom of the cabinet. At the storage panel, the output fibers are temporarily “parked” until they are needed. Service to a subscriber is enabled by removing an unused output fiber from the storage panel, routing it to the appropriate distribution panel, and then connecting it to the subscriber port.

6.1 Storing The Splitter Output Fibers

Use the following procedure to store the splitter output fibers.

1. Following installation of a splitter module, locate an open connector pack slot in the storage panel at the bottom of the cabinet.
2. Insert the connector pack into the unused slot in the storage panel. Refer to the FDH 3000 Plug and Play Splitter Installation Guide (ADCP-96-087) provided with splitter modules for additional information on installing connector packs in the storage panel.
3. Use the radius limiters on the right side of the cabinet to store any excess fiber slack. Refer to [Figure 12](#) for the routing guidelines.

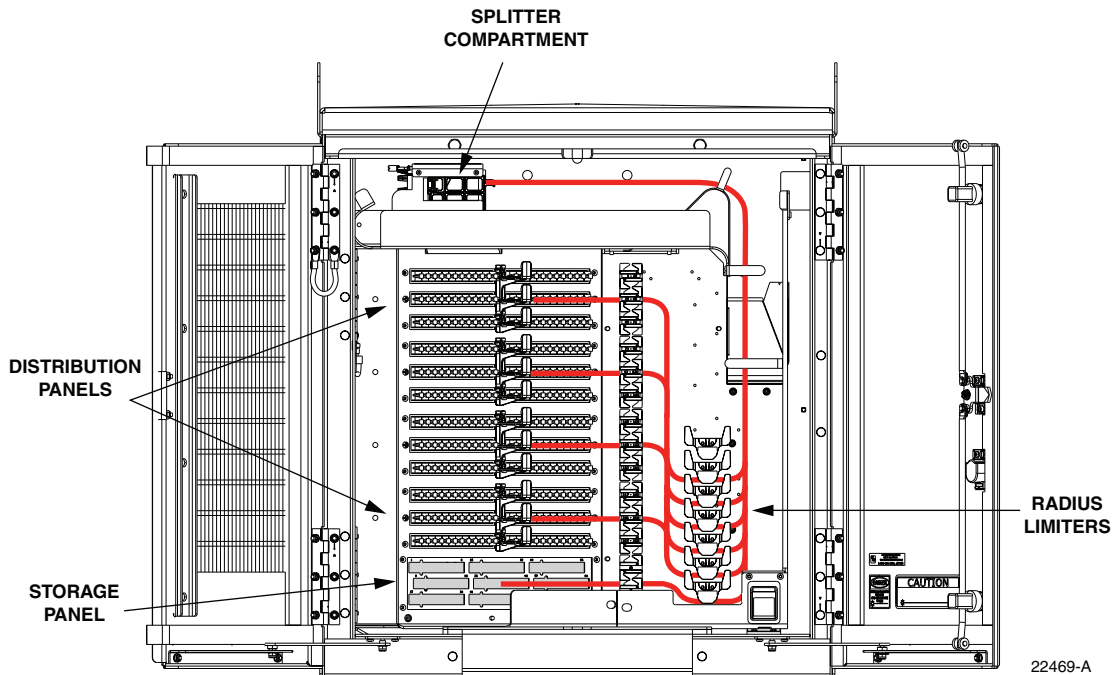

Figure 12. Routing Splitter Output Fibers

6.2 Enabling Service To a Subscriber

Use the following procedure to enable service to a subscriber:

1. Check the designation labels on the cabinet doors to determine the distribution panel and port number that corresponds to the address of the subscriber.
2. Locate the subscriber port on the specified distribution panel and remove both the adapter dust cap and the connector ferrule dust cap.
3. Select and remove an unused splitter output fiber from the storage panel and carefully work it free of any other fibers.



Warning: *Infrared radiation is invisible and can seriously damage the retina of the eye. Do not look into the ends of any optical fiber. Do not look directly into the optical adapters or connectors. Exposure to invisible laser radiation may result. An optical power meter should be used to verify active fibers. A protective cap or hood MUST be immediately placed over any radiating adapter or optical connector to avoid the potential of dangerous amounts of radiation exposure. This practice also prevents dirt particles from entering the adapter or connector.*

4. Remove the ferrule dust cap from the connector and then clean the connector as specified in the Optical Fiber Systems Cleaning and Mating Instructions (ADCP-90-159).
5. Connect the splitter output fiber connector to the subscriber port.
6. Use the radius limiters on the right side of the cabinet to store any excess fiber slack. Refer to [Figure 12](#) for the routing guidelines

7 PASS-THROUGH ROUTING PROCEDURE

Pass-through routing is used when it is necessary for a feeder cable optical signal to be routed directly to a distribution port. This involves connecting a patch cord between the terminated feeder cable connector and the appropriate distribution port. Because feeder cable fibers can be terminated at either the sliding adapter pack or the splitter compartment, two pass-through routing procedures are provided.

7.1 Sliding Adapter Pack Pass-Through Routing Procedure

Use the following procedure to route a jumper patch cord between the feeder cable sliding adapter pack and one of the distribution panels.

1. Locate the “pass-through” feeder cable connector on the sliding adapter pack.
2. Pull upward on the small tab on top of the adapter pack and lift the adapter pack to the access position as shown in [Figure 13](#)

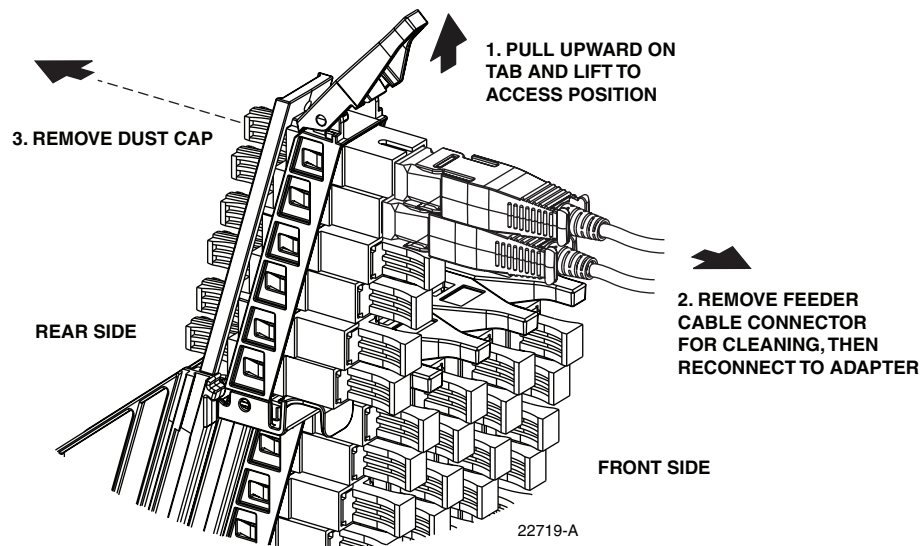

Figure 13. Adapter Pack Raised to Access Position



Warning: Infrared radiation is invisible and can seriously damage the retina of the eye. Do not look into the ends of any optical fiber. Do not look directly into the optical adapters or connectors. Exposure to invisible laser radiation may result. An optical power meter should be used to verify active fibers. A protective cap or hood **MUST** be immediately placed over any radiating adapter or optical connector to avoid the potential of dangerous amounts of radiation exposure. This practice also prevents dirt particles from entering the adapter or connector.

3. Remove the pass-through feeder cable connector from the front of the adapter pack.
4. Clean the feeder cable connector as specified in the Optical Fiber Systems Cleaning and Mating Instructions (ADCP-90-159).

5. Reinstall the pass-through feeder cable connector at the front side of the sliding adapter pack.
6. Remove the dust cap from the rear side of the sliding adapter pack bulkhead adapter.
7. Obtain a **1.9 meter** optical patch cord (accessory) for the pass-through connection.
8. Remove the ferrule dust cap from one of the patch cord connectors and then clean the connector as specified in the Optical Fiber Connector Wet and Dry Cleaning Instructions (ADCP-90-159) or by locally approved procedures.
9. Insert the patch cord connector into the sliding adapter pack bulkhead adapter.
10. Slide the adapter pack down into the closed position.
11. Route the pass-through patch cord to the front side of the swing-out assembly as shown in [Figure 14](#).

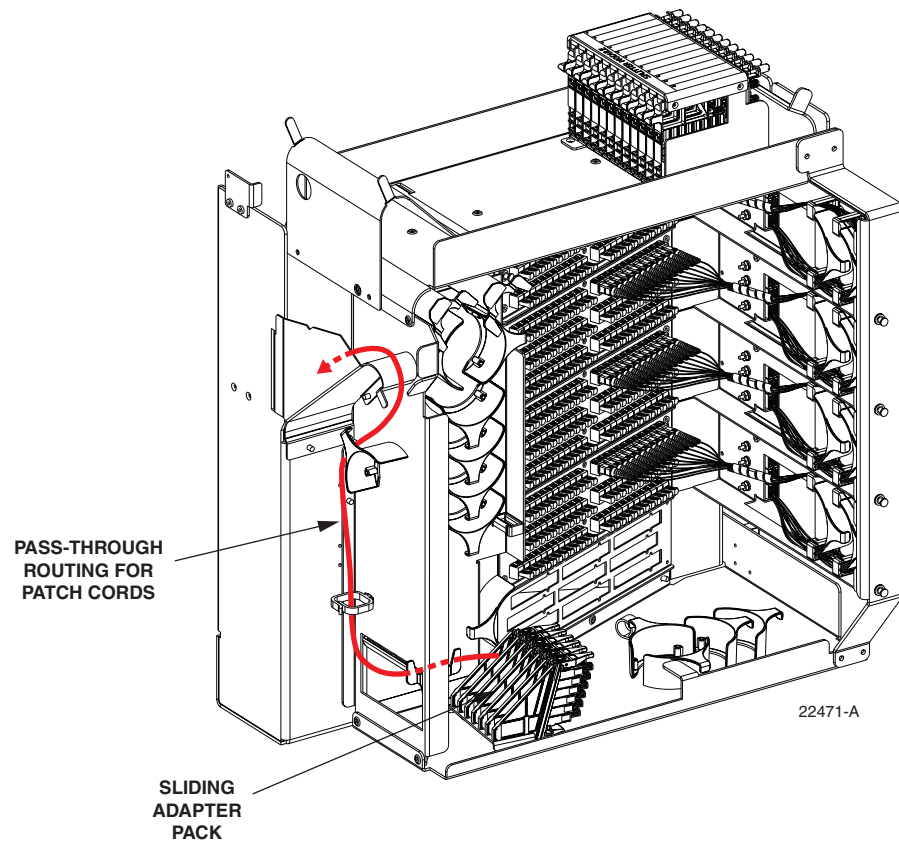

Figure 14. Routing Pass-Through Patch Cord From Sliding Adapter Pack

12. Locate the distribution panel and the optical port to which the pass-through patch cord is to be routed.
13. Refer to the procedures in [Section 6.2](#) to route the pass-through patch cord to the distribution panel and to connect the patch cord connector to the appropriate optical port.

7.2 Splitter Compartment Pass-Through Routing Procedure

Use the following procedure to route a jumper patch cord between the splitter compartment and one of the distribution panels.

1. Locate an open splitter mounting position.
2. Remove the dust cap assembly from the selected splitter slot.
3. Remove the feeder cable connector(s) from the rear of the splitter compartment (see [Figure 10](#)).



Warning: Infrared radiation is invisible and can seriously damage the retina of the eye. Do not look into the ends of any optical fiber. Do not look directly into the optical adapters or connectors. Exposure to invisible laser radiation may result. An optical power meter should be used to verify active fibers. A protective cap or hood **MUST** be immediately placed over any radiating adapter or optical connector to avoid the potential of dangerous amounts of radiation exposure. This practice also prevents dirt particles from entering the adapter or connector.

4. Clean the feeder cable connector(s) as specified in the Optical Fiber Systems Cleaning and Mating Instructions (ADCP-90-159).
5. Reinstall the feeder cable connector(s) at the rear of the splitter compartment.
6. Obtain a **1.3 meter** optical patch cord (accessory) for the pass-through connection.
7. Remove the ferrule dust cap from one of the patch cord connectors and then clean the connector as specified in the Optical Fiber Connector Wet and Dry Cleaning Instructions (ADCP-90-159) or by locally approved procedures.
8. Install the patch cord connector in the dust cap assembly as shown in [Figure 15](#).

► **Note:** Two patch cord connectors may be installed in the dust cap assembly if required.

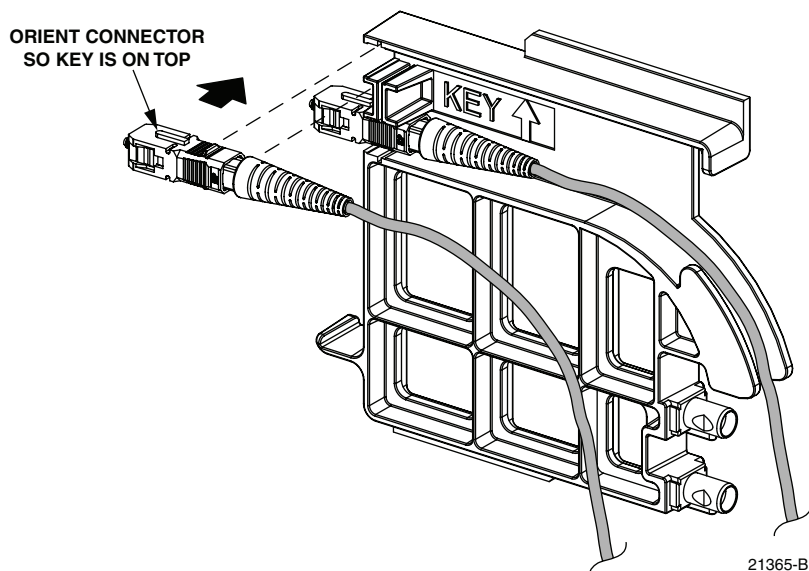

Figure 15. Installing Patch Cord Connector in Dust Cap Assembly

9. Connect the patch cord connector(s) to the feeder cable connector(s) by inserting the dust cap assembly into the splitter slot as shown in [Figure 16](#).
10. Locate the distribution panel and the optical port to which the pass-through patch cord is to be routed.
11. Refer to the procedures in [Section 6.2](#) to route the pass-through patch cord to the distribution panel and to connect the patch cord connector to the appropriate optical port.

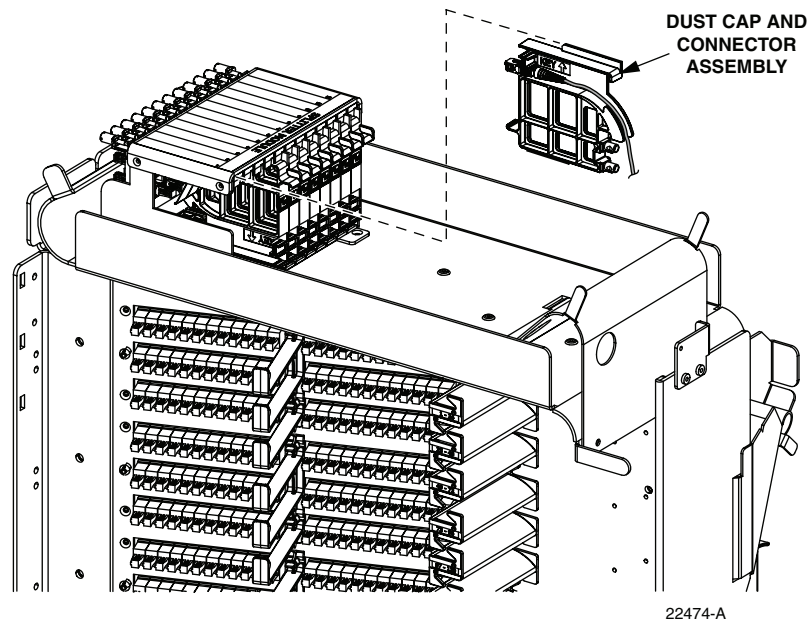

Figure 16. Inserting Dust Cap Assembly

8 FEEDER CABLE FIBER RE-ROUTING PROCEDURE

The feeder cable fibers may be terminated by the factory at either the sliding adapter pack or at the splitter compartment. Feeder cable fibers that were terminated at the sliding adapter pack may sometime require re-termination at the splitter compartment. Use the following procedure to re-route a feeder cable fiber from the sliding adapter pack to the splitter compartment.

1. At the sliding adapter pack, locate the feeder cable fiber that requires re-termination at the splitter compartment.
2. Pull upward on the small tab on top of the adapter pack and lift the adapter pack to the access position as shown in [Figure 13](#).

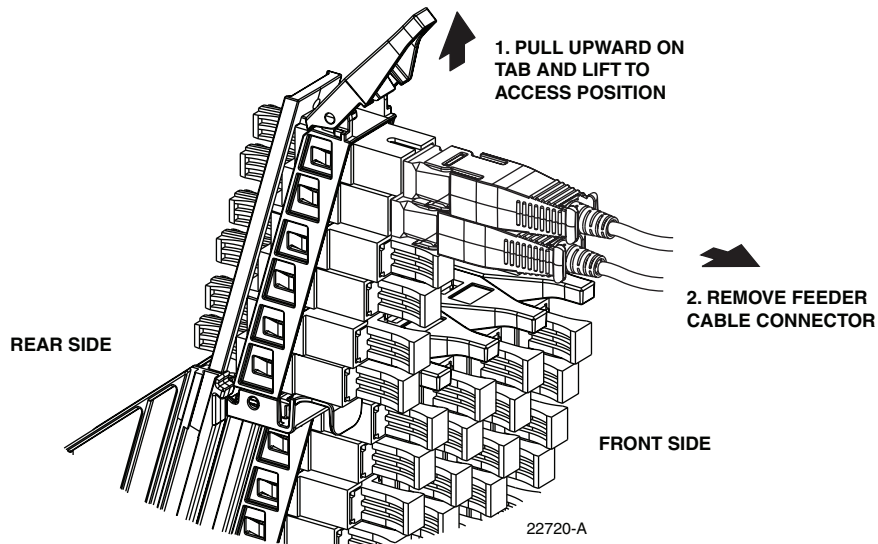

Figure 17. Adapter Pack Raised to Access Position

3. Disconnect the feeder cable connector from the front side of the sliding adapter pack and place a dust cap over the connector ferrule. This will protect the connector since it will be difficult to prevent the connector from contacting other objects during the re-routing procedure.



Warning: *Infrared radiation is invisible and can seriously damage the retina of the eye. Do not look into the ends of any optical fiber. Do not look directly into the optical adapters or connectors. Exposure to invisible laser radiation may result. An optical power meter should be used to verify active fibers. A protective cap or hood MUST be immediately placed over any radiating adapter or optical connector to avoid the potential of dangerous amounts of radiation exposure. This practice also prevents dirt particles from entering the adapter or connector.*

4. Place a dust cap over the exposed bulkhead adapter and then slide the adapter pack down to the closed position.
5. Carefully unwind the feeder fiber from the radius limiters located on the bottom and on the left side of the swing-out assembly. [Figure 18](#) shows the section of the fiber that will need to be released for re-routing. When necessary, backfeed the fiber to free the connector from the remaining fibers.

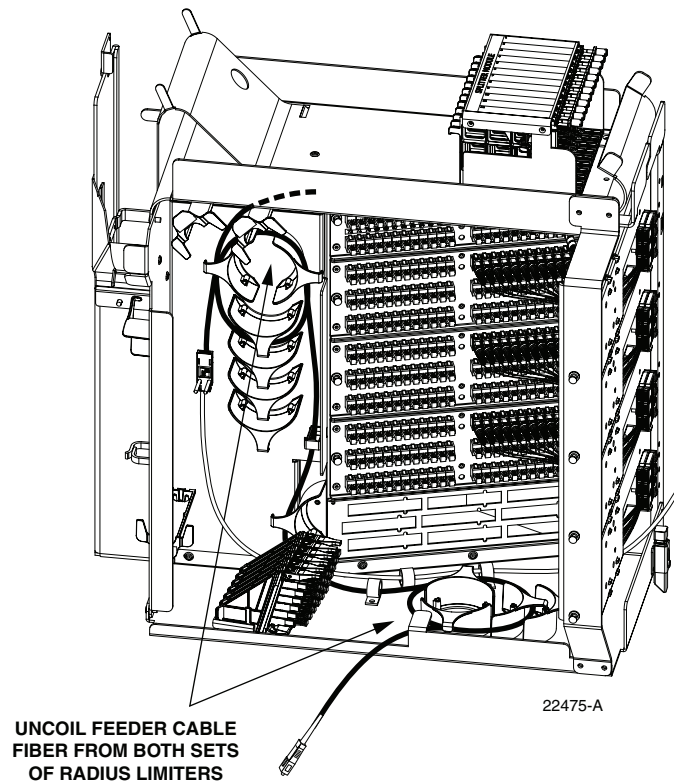

Figure 18. Uncoiling the Feeder Cable Fiber

6. When the feeder cable connector and fiber are free, pass the connector through the opening located behind the splitter compartment as shown in [Figure 19](#).
7. Remove the ferrule dust cap from the feeder cable connector and then clean the connector as specified in the Optical Fiber Connector Wet and Dry Cleaning Instructions (ADCP-90-159) or by locally approved procedures.
8. Insert the feeder fiber connector into the appropriate bulkhead adapter (remove dust cap from adapter) at the rear of the splitter compartment as shown in [Figure 20](#).
- **Note:** The splitter slot should not be left empty after the feeder fiber is connected to the bulkhead adapter at the rear side of the splitter compartment. Either a dust cap assembly or a splitter should be installed in the mounting slot.
9. Route the feeder fiber over the two supports located at the top of the swing-out assembly.
10. Store the excess slack on the radius limiters located on the left side of the swing-out assembly.

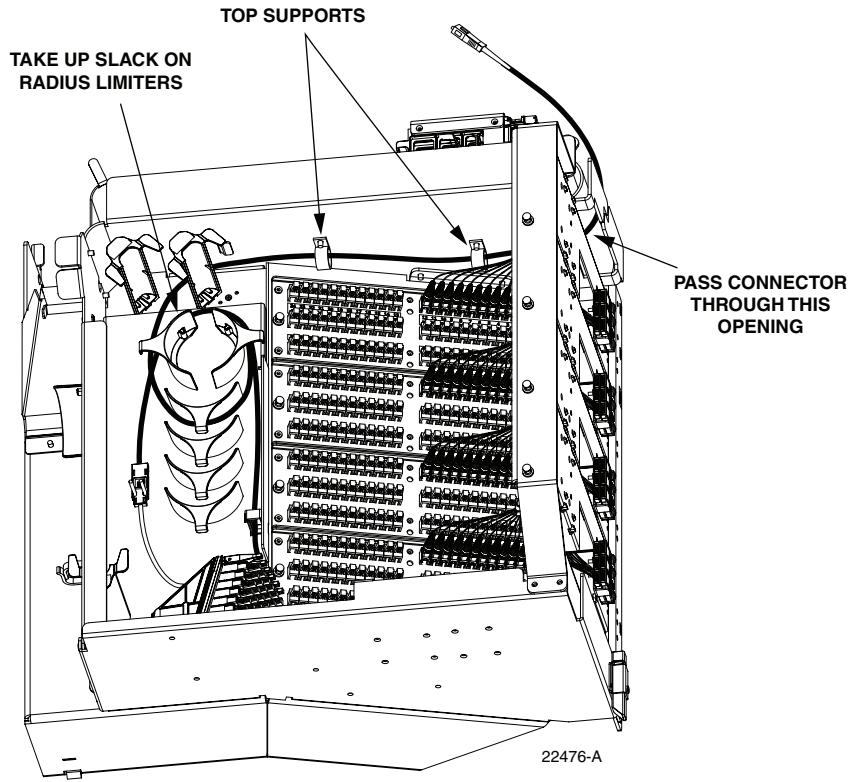

Figure 19. Re-Routing the Feeder Cable Fiber

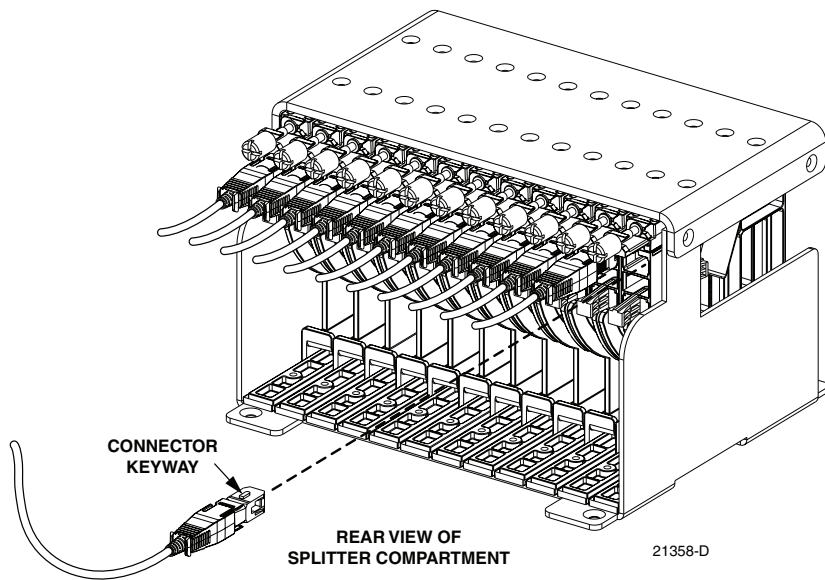

Figure 20. Feeder Cable Connector

9 MAINTENANCE AND REPAIR PROCEDURES

The 288 pole-mount cabinet requires no regular maintenance to insure continuous and satisfactory operation. Maintenance is limited to repairing or replacing any cabinet components that may be damaged or broken in the course of normal operation. The following sections provide procedures for repairing or replacing common cabinet components.

9.1 Painting

A brush-in-cap bottle of paint (ACE-ACC-PTALMD) is available for touching-up nicks and scratches in the factory coat of paint. Lightly sand the area to be painted and then clean it thoroughly to remove any dirt, dust, or foreign matter. Shake the paint bottle until thoroughly mixed and then apply a light coat of paint to the damaged area using the small brush attached to the cap. Wait until the paint is dry and then apply a second coat if necessary. When finished painting, replace the paint bottle cap and tighten securely.

9.2 Distribution Panel Adapter Replacement

Replacement adapters are available for the distribution panels. Use the following procedure to remove and replace a damaged adapter:

1. Disconnect the splitter output connector from the front side of the broken adapter as shown in [Figure 21](#) and install a dust cap on the connector.



Warning: *Infrared radiation is invisible and can seriously damage the retina of the eye. Do not look into the ends of any optical fiber. Do not look directly into the optical adapters or connectors. Exposure to invisible laser radiation may result. An optical power meter should be used to verify active fibers. A protective cap or hood MUST be immediately placed over any radiating adapter or optical connector to avoid the potential of dangerous amounts of radiation exposure. This practice also prevents dirt particles from entering the adapter or connector.*

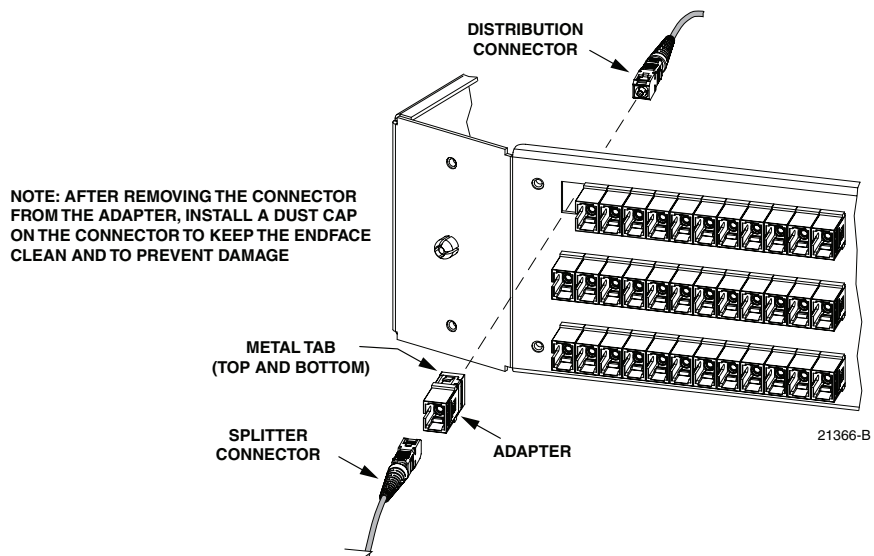

Figure 21. Adapter Removal and Replacement

2. Unlatch and fully open the cabinet swing assembly to provide access to the rear side of the distribution panel.
3. Disconnect the distribution connector from the rear side of the broken adapter and install a dust cap on the connector.



Caution: Use extreme care when removing a connector or an adapter from the distribution panel to avoid macro bending the adjacent fibers.

4. Working from the rear side of the distribution panel, use the SC adapter removal tool (catalog # FCC-ACC003) to depress the two metal tabs that retain the adapter in the panel. Then push forward on the adapter until it pops out of the panel.
 5. Discard the damaged adapter.
 6. Install the replacement adapter by inserting it into the distribution panel from the front and then pushing it toward the back until it snaps into place.
- **Note:** Make sure the keyway in the replacement adapter is facing in the same direction as the keyways in the rest of the adapters installed in the distribution panel.
7. Clean the distribution and splitter fiber connectors as specified in the Optical Fiber Systems Cleaning and Mating Instructions (ADCP-90-159).
 8. Connect the distribution connector to the rear side of the replacement adapter.
 9. Close the cabinet swing assembly.
 10. Connect the splitter connector to the front side of the replacement adapter.

9.3 Splitter Compartment Adapter Replacement

Replacement adapter assemblies are available for the splitter compartment. Use the following procedure to remove and replace a damaged adapter assembly:

1. Unlatch and fully open the cabinet swing assembly to provide access to the both the front and rear side of the splitter compartment.
2. Remove the splitter or the dust cap assembly from the front side of the broken adapter assembly.



Warning: Infrared radiation is invisible and can seriously damage the retina of the eye. Do not look into the ends of any optical fiber. Do not look directly into the optical adapters or connectors. Exposure to invisible laser radiation may result. An optical power meter should be used to verify active fibers. A protective cap or hood **MUST** be immediately placed over any radiating adapter or optical connector to avoid the potential of dangerous amounts of radiation exposure. This practice also prevents dirt particles from entering the adapter or connector.

3. Remove the feeder cable connector(s) from the rear side of the broken adapter assembly as shown in [Figure 22](#) and install a dust cap on the connector(s).
4. Turn the thumb screw on the top of the broken adapter assembly clockwise until the adapter assembly detaches from the top of the splitter compartment.
5. Discard the damaged adapter assembly.

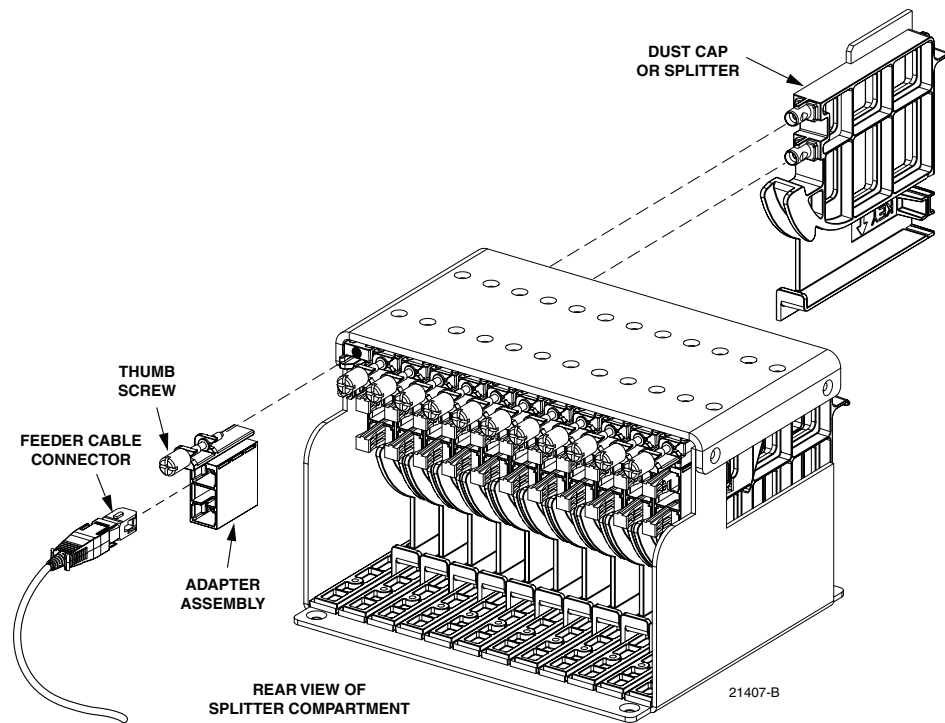

Figure 22. Splitter Compartment Adapter Replacement

6. Install the replacement adapter assembly in the splitter compartment and secure it by turning the thumbscrew counter-clockwise until tight.
7. Clean the feeder cable connector(s) as specified in the Optical Fiber Systems Cleaning and Mating Instructions (ADCP-90-159).
8. Connect the feeder cable connector to the rear side of the replacement adapter assembly.
9. Connect the dust cap or splitter to the front side of the replacement adapter assembly.
10. Close the cabinet swing assembly.

9.4 Replacing a Damaged Fiber or Connector

A damaged fiber or connector can usually be replaced. The following describes the various replacement options.

- **Damaged Splitter Output Fiber:** Replace the splitter output fiber from the connector all the way back into the splitter. Splice a new pigtail (use only pigtails with bend-optimized fiber) to the remaining section of the old fiber within the splitter chassis. This procedure requires removing and disassembling the splitter to insert a splice chip and to perform the splice. A kit is available from ADC. Refer to ADCP-96-034 for the procedure.
- **Damaged Distribution or Feeder Connector:** Replace the connector at the bulkhead adapter if just the connector alone is damaged. Use a field-installable connector replacement kit. Refer to [Section 9.4.1](#) for the replacement procedures.

9.4.1 Splitter Output Fiber Connector Replacement

Use the following procedure to replace the connector:

1. Disconnect the damaged connector and the good connector from the adapter and install a dust cap on the good connector.



Warning: *Infrared radiation is invisible and can seriously damage the retina of the eye. Do not look into the ends of any optical fiber. Do not look directly into the optical adapters or connectors. Exposure to invisible laser radiation may result. An optical power meter should be used to verify active fibers. A protective cap or hood MUST be immediately placed over any radiating adapter or optical connector to avoid the potential of dangerous amounts of radiation exposure. This practice also prevents dirt particles from entering the adapter or connector.*

2. Replace the damaged connector as specified in the procedures provided with the field-installable connector replacement kit.
3. Clean both connectors as specified in the Optical Fiber Connector Wet and Dry Cleaning Instructions (ADCP-90-159) or by locally approved procedures.
4. Reconnect the good connector and the replacement connector to the adapter.

9.5 Door Gasket Replacement

Damaged door gaskets may be replaced using the door gasket kit which includes a roll of gasket material. The ideal installation temperature for the adhesive used on the replacement gaskets is between 60 and 100 °F (16 and 38 °C). Installation is not recommended if the temperature is below 50 °F (10 °C). Remove any damaged sections of gasket material from the door. If necessary, use a citrus based adhesive cleaner to remove any adhesive that may stay attached to the door. Cut replacement lengths of gasket material from the roll as needed. Remove the paper backing to expose the adhesive and then carefully apply the replacement gasket to the door. Take care not to leave any gaps between the meeting sections of the gasket strips.

9.6 Door Replacement

Damaged cabinet doors may be replaced using the door replacement kit. Both a right door kit (FD3-ACCDR288PLRT) and a left door kit (FD3-ACCDR288PLLT) are available. Use the following procedure to remove and replace the cabinet doors:

1. Open both cabinet doors and lock them in the open position as shown in [Figure 23](#).
2. Use a 3/8-inch nut driver to remove the locking nuts and washers that secure the door bracket slide to the bottom edge of the door as shown in [Figure 24](#). Save the nuts and washers for reuse.
3. Use a 3/8-inch nut driver to remove the locking nuts that secure the hinges to the door. Save nuts for reuse.

► **Note:** Support the door as the last nuts are removed to prevent the door from falling.

4. Carefully lift the door away from the cabinet.

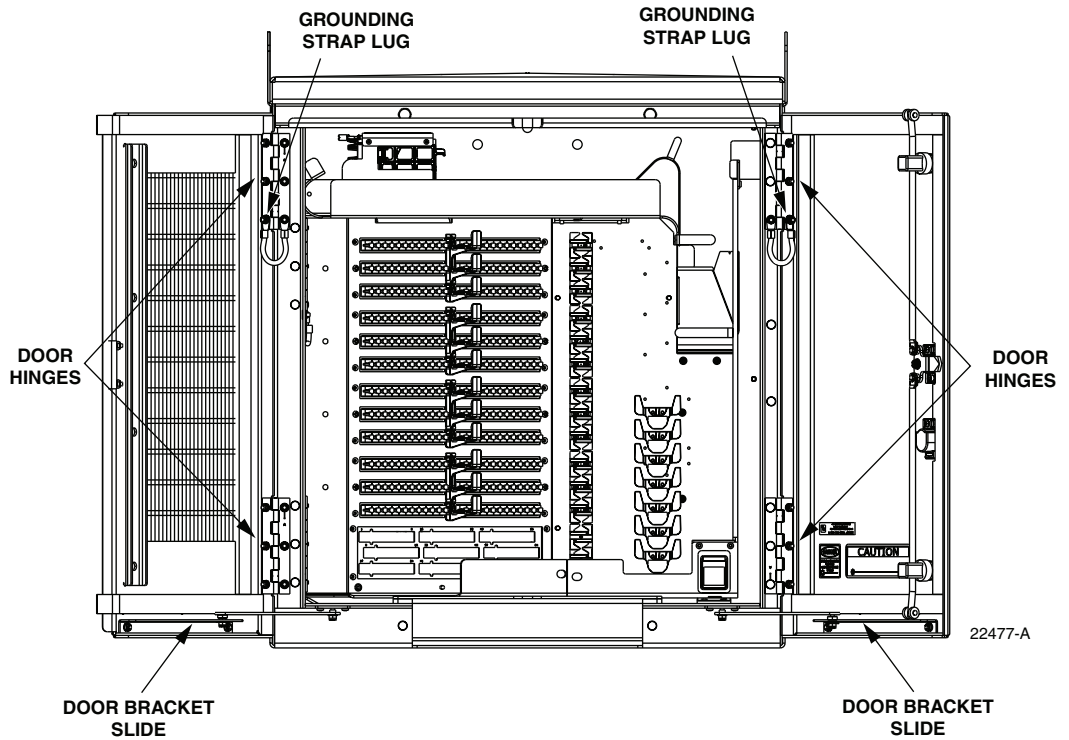

Figure 23. Door Replacement

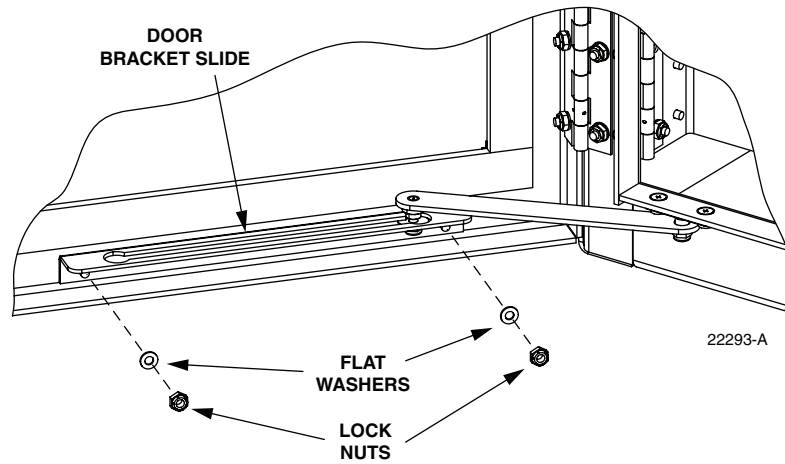

Figure 24. Door Linkage Hardware

5. Transfer all designation information that may be recorded on the damaged door to the labels on the replacement door.
6. Place the replacement door in position for installation on the hinges.

7. Reinstall the locking nuts (saved in step 3) that secure each hinge to the door.
- ▶ **Note:** Be sure to re-secure the grounding strap lug (see [Figure 23](#)) to the door when securing the hinges to the door.
8. Secure the door bracket slide to the bottom edge of the door using the locking nuts and washers saved in step 2.
9. Repeat process for the left door.
10. Close doors and check for proper operation.

10 CUSTOMER INFORMATION AND ASSISTANCE



PHONE:

U.S.A. or CANADA

Sales: 1-800-366-3691
 Extension 73000
 Technical Assistance: 1-800-366-3891
 Connectivity Extension: 73475
 Wireless Extension: 73476

EUROPE

Sales Administration: +32-2-712-65 00
 Technical Assistance: +32-2-712-65 42

EUROPEAN TOLL FREE NUMBERS

Germany: 0180 2232923
 UK: 0800 960236
 Spain: 900 983291
 France: 0800 914032
 Italy: 0800 782374

ASIA/PACIFIC

Sales Administration: +65-6294-9948
 Technical Assistance: +65-6393-0739

ELSEWHERE

Sales Administration: +1-952-938-8080
 Technical Assistance: +1-952-917-3475

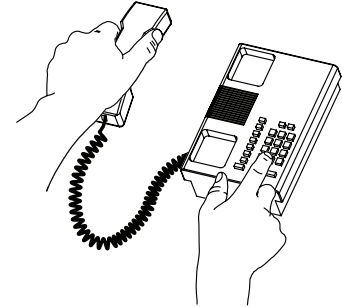

13944-P

WRITE:

ADC Telecommunications (S'PORE) PTE, LTD;
 100 Beach Road, #18-01, Shaw Towers.
 Singapore 189702.

ADC Telecommunications, INC
 PO Box 1101,
 Minneapolis, MN 55440-1101, USA

ADC European Customer Service, INC
 Belgicastraat 2,
 1930 Zaventem, Belgium

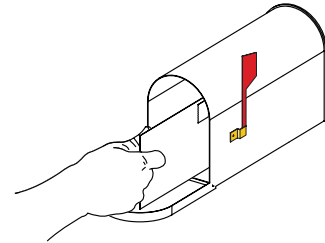

PRODUCT INFORMATION AND TECHNICAL ASSISTANCE:

connectivity.tac@adc.com

wireless.tac@adc.com

euro.tac@adc.com

asiapacific.tac@adc.com

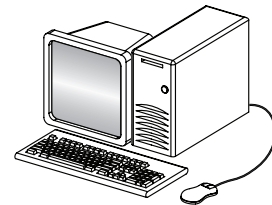

REPRINTS:

PDF copies of manuals are available
 for downloading at the following link:

www.adc.com/manuals

ADCP Number:

96-133

Contents herein are current as of the date of publication. ADC reserves the right to change the contents without prior notice. **In no event shall ADC be liable for any damages resulting from loss of data, loss of use, or loss of profits and ADC further disclaims any and all liability for indirect, incidental, special, consequential or other similar damages. This disclaimer of liability applies to all products, publications and services during and after the warranty period.**





Website: www.adc.com