

VC-GPSWM



GPS Antenna Wall Mount, 1.05 in OD x 48 in

Product Classification

Product Type Wall mount kit

General Specifications

Mounting Walls

Pipe, quantity 1

Dimensions

Height 254 mm | 10 in

Width 254 mm | 10 in

Length 1,219.2 mm | 48 in

Pipe Length 1,219.2 mm | 48 in

Pipe Outer Diameter 27.94 mm | 1.1 in

VC-GPSWM

Outline Drawing

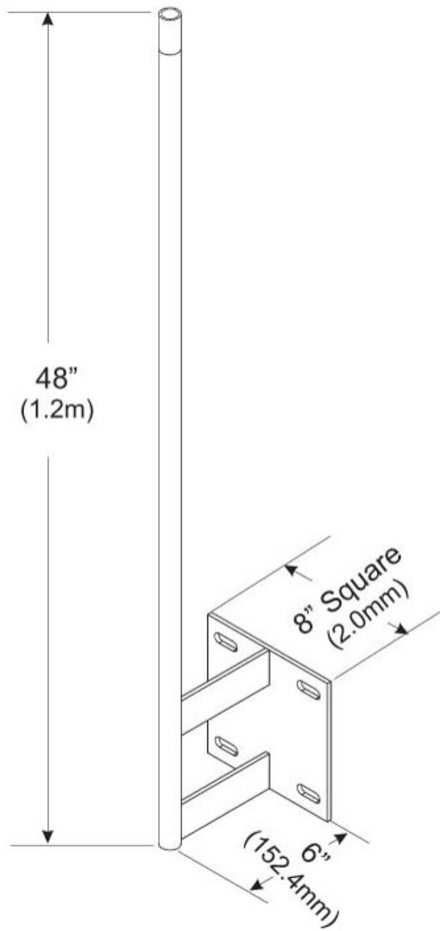

Material Specifications

Material Type Hot dip galvanized steel

Mechanical Specifications

Wind Rating For Specifications, please contact your local ANDREW representative

Packaging and Weights

Included Mount

Packaging quantity 1

Weight, net 4.8 kg | 10.582 lb

VC-GPSWM

Regulatory Compliance/Certifications

Agency	Classification
CHINA-ROHS	Above maximum concentration value
ISO 9001:2015	Designed, manufactured and/or distributed under this quality management system
ROHS	Compliant/Exempted
UK-ROHS	Compliant/Exempted



* Footnotes

Wind Rating BWS—Base Wind Speed; FBC—Florida Building Code