

4

3

2

1

- 1.0 GENERAL NOTES
  - 1.1 ALL METRIC DIMENSIONS ARE IN BRACKETS [X.X]
  - 1.2 FOR PATENT INFO: <https://www.cs-pat.com>
- 2.0 DESIGN NOTES
  - 2.1 USE DRAWING MC-RMHD-1545-4 TO ASSEMBLE RING MOUNT
  - 2.2 ANY HAZARDS OR OBSTRUCTIONS TO THE CLIMBING FACILITY AND SAFETY CLIMB MUST BE IDENTIFIED PRIOR TO INSTALLING THE APPURTENANCE. ADDITIONAL PRODUCTS MAY BE REQUIRED TO MAINTAIN THE INTEGRITY OF THE SAFETY CLIMB. DURING INSTALLATION, TEMPORARY AND/OR PERMANENT PRECAUTIONARY MEASURES SHOULD BE TAKEN TO PRESERVE THE CLIMBING FACILITY AND/OR SAFETY CLIMB.
- 3.0 MANUFACTURING/SPECIAL REQUIREMENTS
  - 3.1 TIGHTEN ALL BOLTS SECURING FLAT PLATES BY THE TURN-OF-NUT METHOD. TIGHTEN ALL U-BOLTS USING TURN-OF-NUT METHOD WITH ATTENTION TO LEAVE EQUAL DISTANCE AND EQUAL FORCE ON EACH LEG OF THE U-BOLT.
- 4.0 TEST
- 5.0 PACKAGING
  - 5.1 PACKAGING SHALL MEET COMMSCOPE REQUIREMENTS PER DOCUMENT IS-PL-3005
  - 5.2 PRINTED DOCUMENT TO BE PLACED INSIDE POLYBAG AND THEN IN SHIPPING CONTAINER
  - 5.3 EXTRA HARDWARE MAYBE SUPPLIED, BAGGED AND SHIPPED

REVISIONS			
REV.	DESCRIPTION	DATE	APPROVED
A	INITIAL RELEASE	YMENG 19OCT21	BA1025 14658
B	MCPM-2005-00 WAS MCPM-2000-00, MT-219N-H WAS MT21703 KIT, GB-0524A WAS GB-0522A, ALL U-BOLTS CHANGED TO GUB-4352	JYANG4 22SEP22	BA1025 40156827CMO

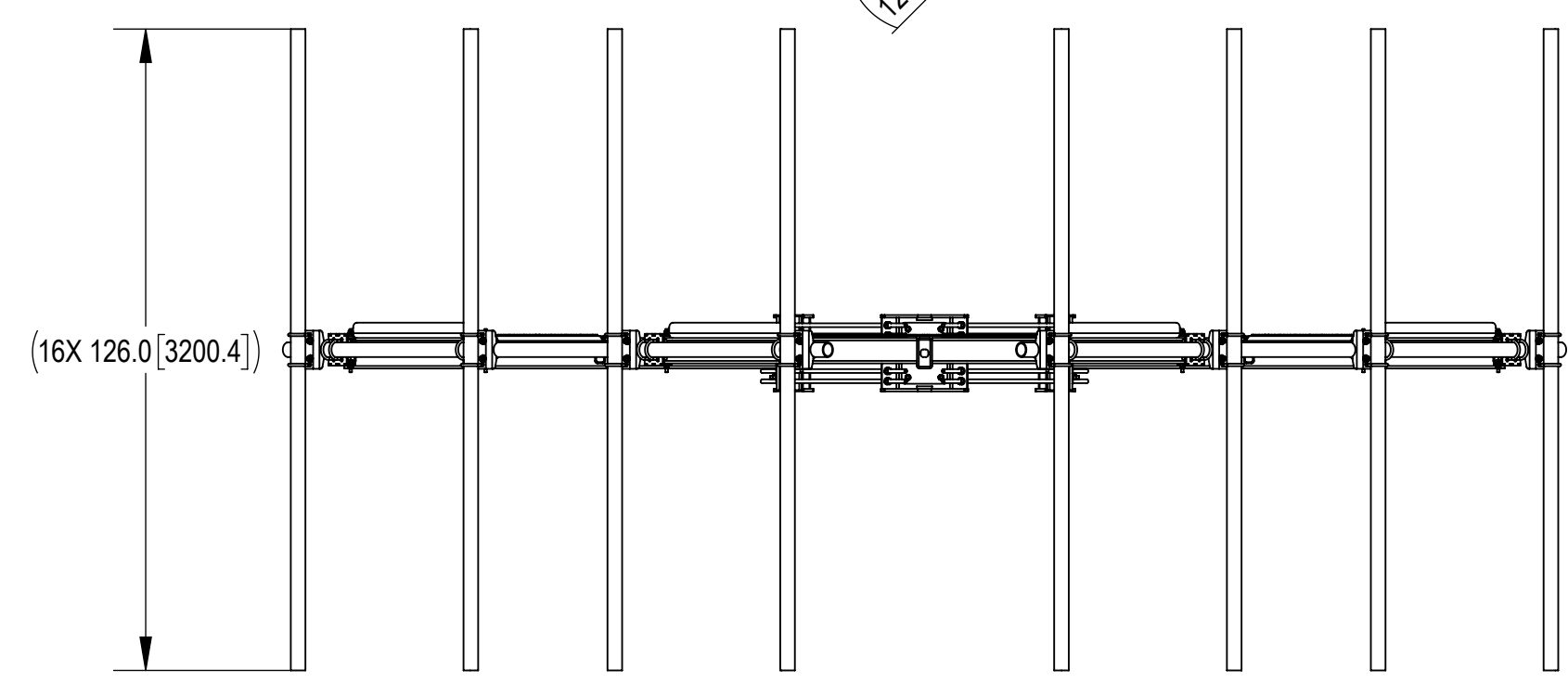
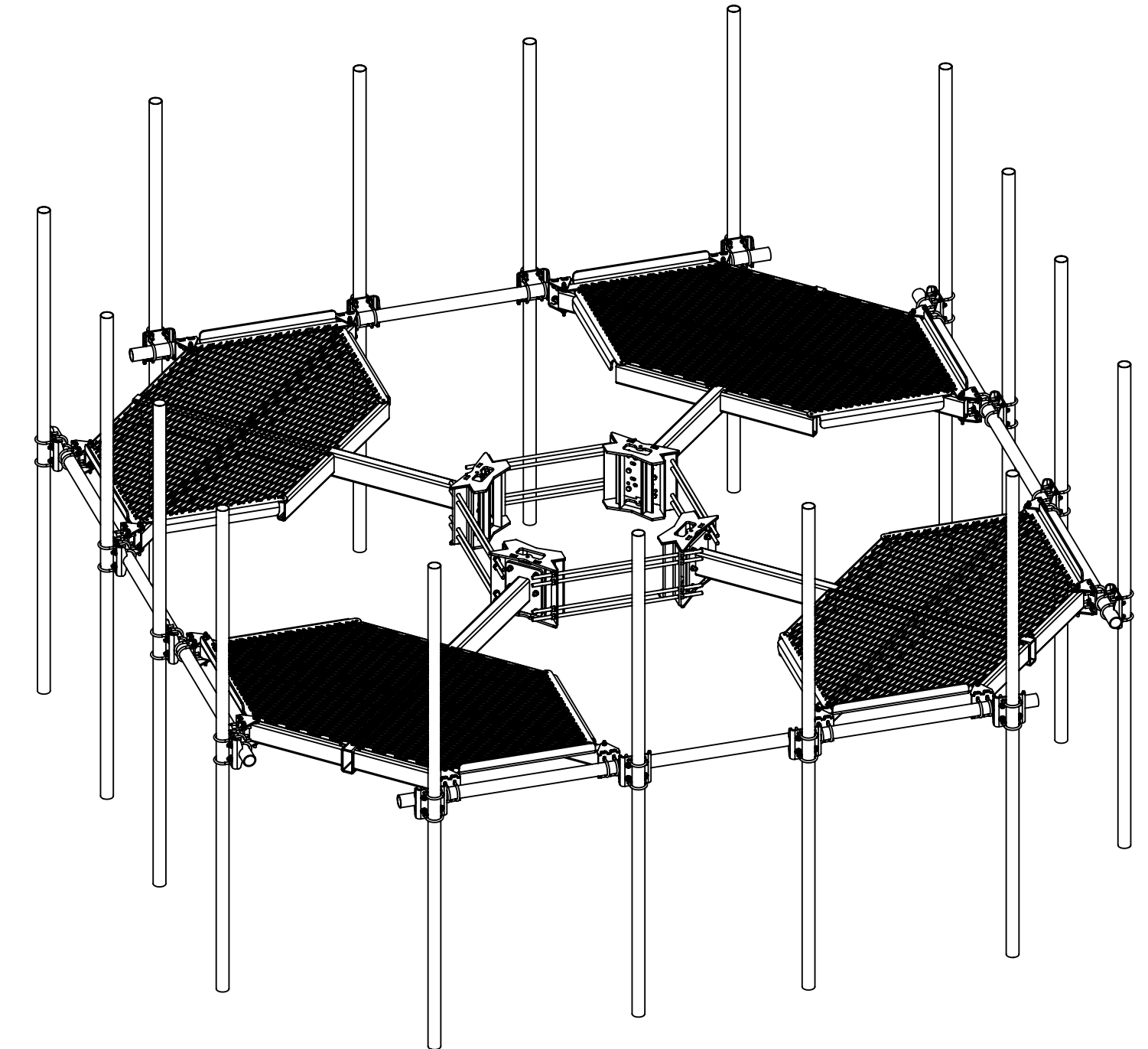
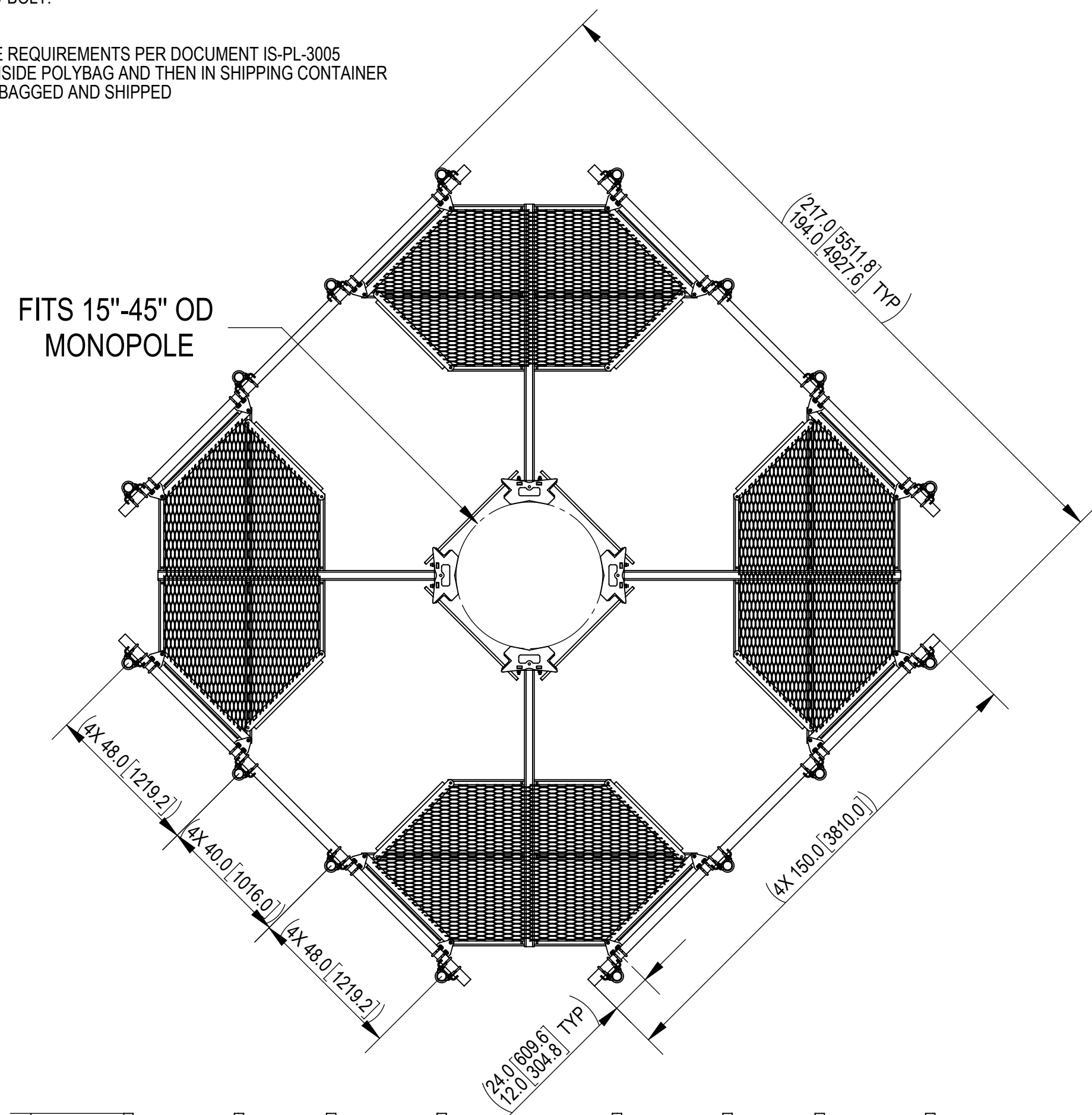

DENSITY		lbs/in <sup>3</sup>
MASS	3483.58	lbs
VOLUME	13372.68	in <sup>3</sup>
SURFACE AREA	118083.41	in <sup>2</sup>
HEIGHT	126[3200]	
LENGTH	217[5512]	
WIDTH	217[5512]	

**COMMSCOPE, INC. OF NORTH CAROLINA**

TOLERANCES		SAP MATERIAL MASTER							
1 PLACE .X[X] ± 0.25[6.3]	3 PLACE .XXX[X] ± 0.060[1.5]	<b>MC-PM12M4-16-126</b>							
2 PLACE .XX[X] ± 0.12[3.0]	ANGLES ± 2°								
FINISH		MATERIAL							
<small>UNLESS OTHERWISE SPECIFIED DIMENSIONS ARE IN INCHES INTERPRET PER ANSI Y 14.5M-1994</small>		NAME	DATE	TITLE					
		CE YMENG	08/31/2021	<b>ATLAS4, 12' FP, (16)2.88" X126"AP</b>					
		RW HDAI	09/06/2023						
		AD YMENG	09/06/2023						
RE HDAI	09/06/2023								
ECN 40156827CMO		SCALE	DOCUMENT NO.						
		<b>1:48</b>	<b>MC-PM12M4-16-126</b>						
SIZE	Auth Group	INSL	MODEL	DRAWING		SHEET			
<b>C</b>			VERSION	STATUS	REVISION	VERSION	STATUS	REVISION	1 OF 7
			01	RE	B	01	RE	B	

4

3

2

1

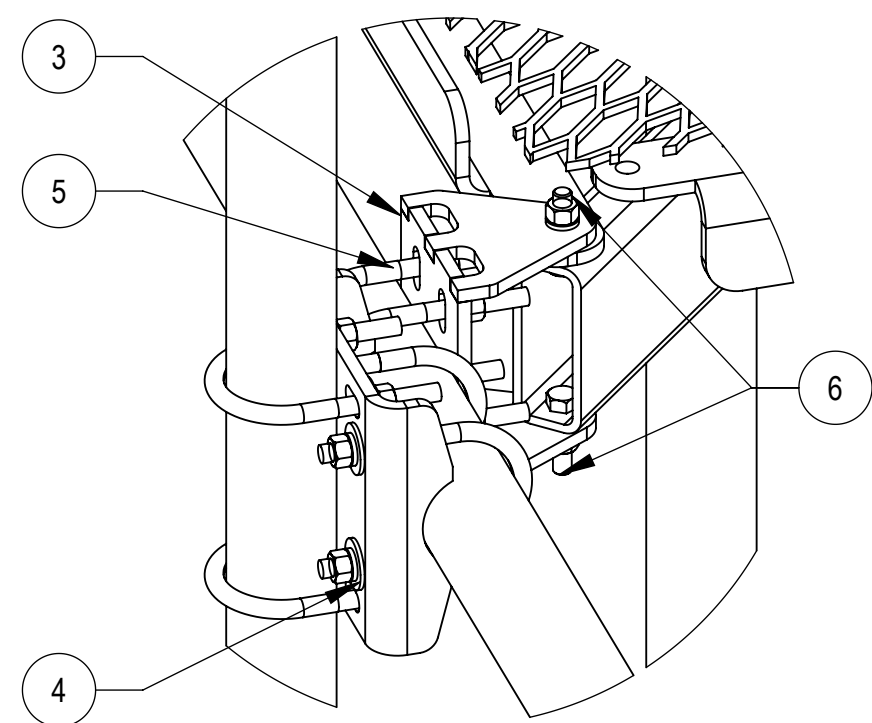

**DETAIL A**  
SCALE 1 : 5

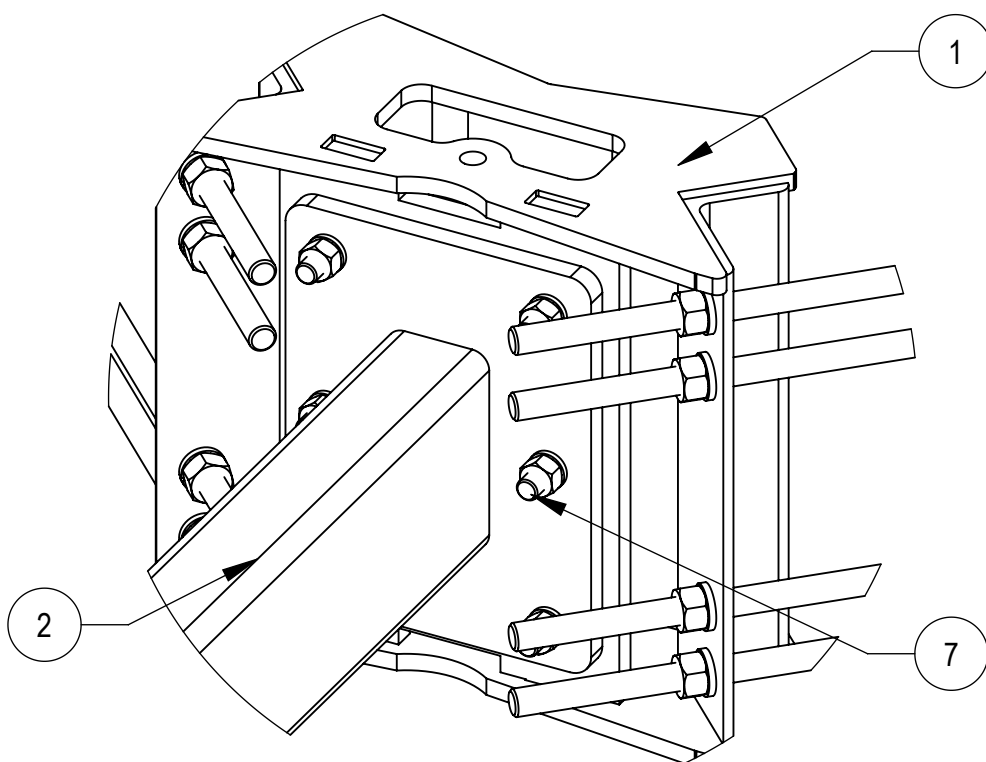

**DETAIL B**  
SCALE 1 : 5

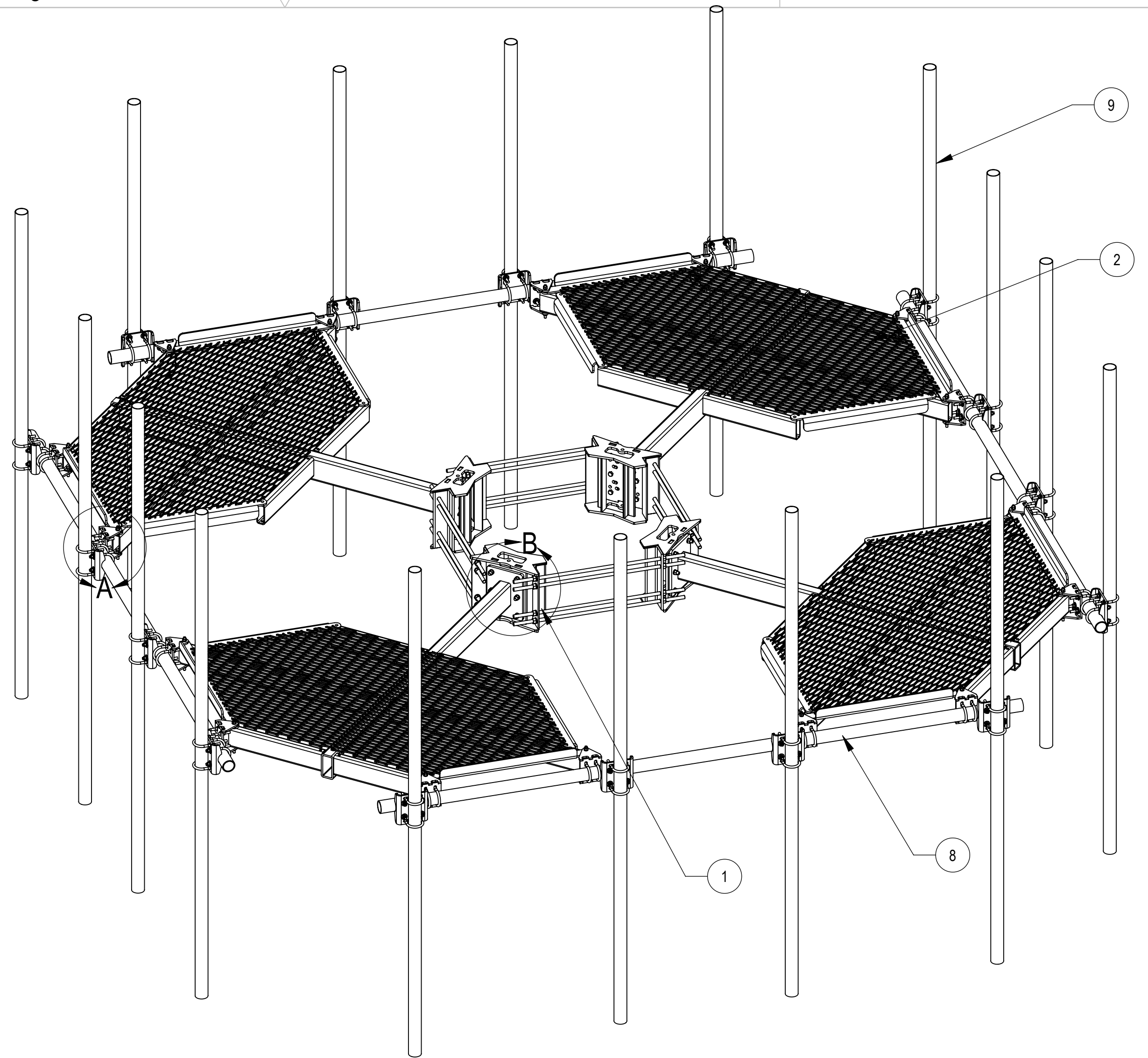

COMPONENT PART NUMBERS PROVIDED FOR ASSEMBLY PURPOSES;  
INDIVIDUAL COMPONENTS MAY BE SHIPPED AS PARTS WITHIN AN INCLUDED KIT.

ITEM	PART NO.	DESCRIPTION	QTY.	WEIGHT	NOTE NO.
1	MC-RMHD-1545-4	4 SECTOR RING MOUNT, 15"-45" POLE	1	386.57LBS	
2	MC-PM4-2000	WELDMENT, CO-LOCATION PLATFORM	4	477.02 LBS	
3	MCPM-2005-00	BRACKET, PIPE MOUNTING	16	5.47 LBS	△B
4	MT-219N-H	SADDLE PIPE MOUNTING KIT, 2-7/8" OD	16	10.61 LBS	△B
5	GUB-4352	1/2" X 3" X 5-1/4" GALV U-BOLT	32	0.71 LBS	△B
6	GB-04205	1/2" X 2" GALV BOLT KIT	32	0.16 LBS	
7	GB-0524A	5/8" X 2-1/2" GALV BOLT KIT (A325)	24	0.30 LBS	△B
8	MT-546-150	PIPE, 2.875"OD X 150"	4	72.67 LBS	
9	MT546126120	PIPE, 2.875"OD X 126"	16	37.21 LBS	

COMMSCOPE, INC. OF NORTH CAROLINA				
TITLE ATLAS4, 12' FP,(16)2.88" X126"AP				
SIZE C	SCALE 1:48	DOCUMENT NO. MC-PM12M4-16-126		
DRAWING		VERSION	STATUS	REVISION
		01	RE	B
				SHEET 2 OF 7

4

3

2

1

1X

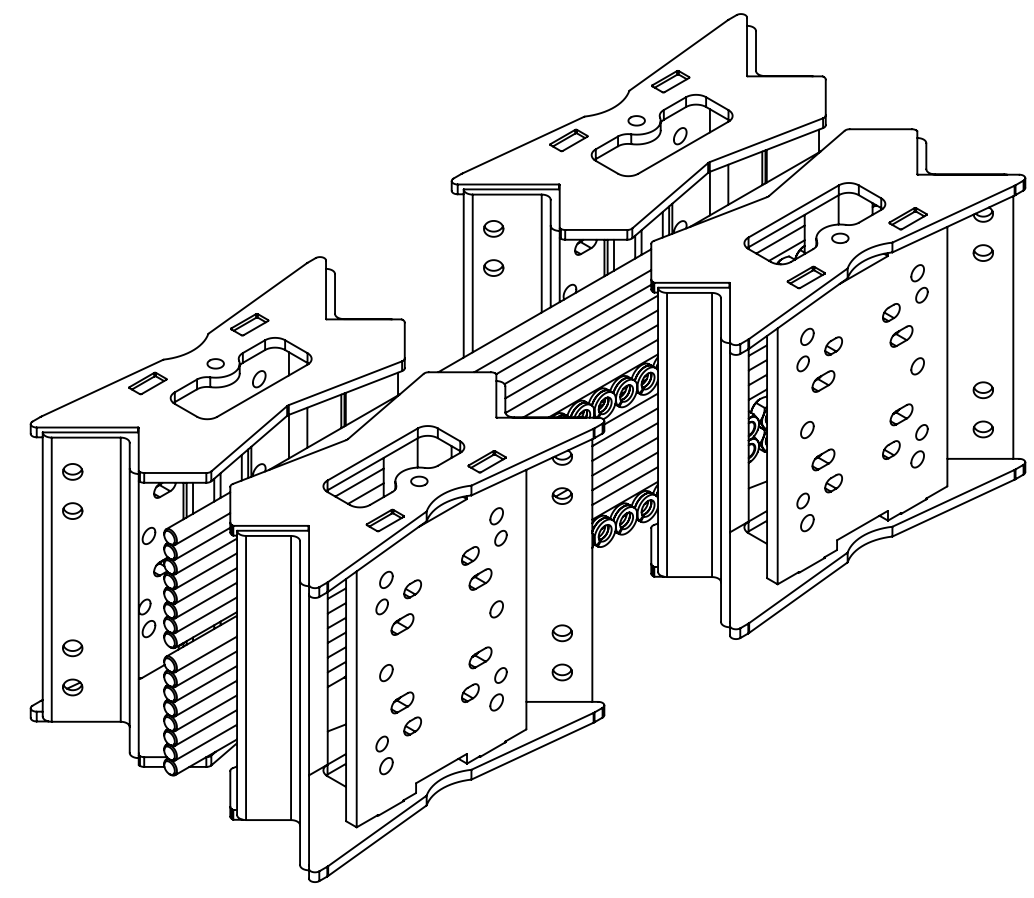

MC-RMHD-1545-4

(INCLUDING 1X RMHD1545-4-1000, 16X MT38440, 32X GWL-06 AND 32X GN-06 )

4X

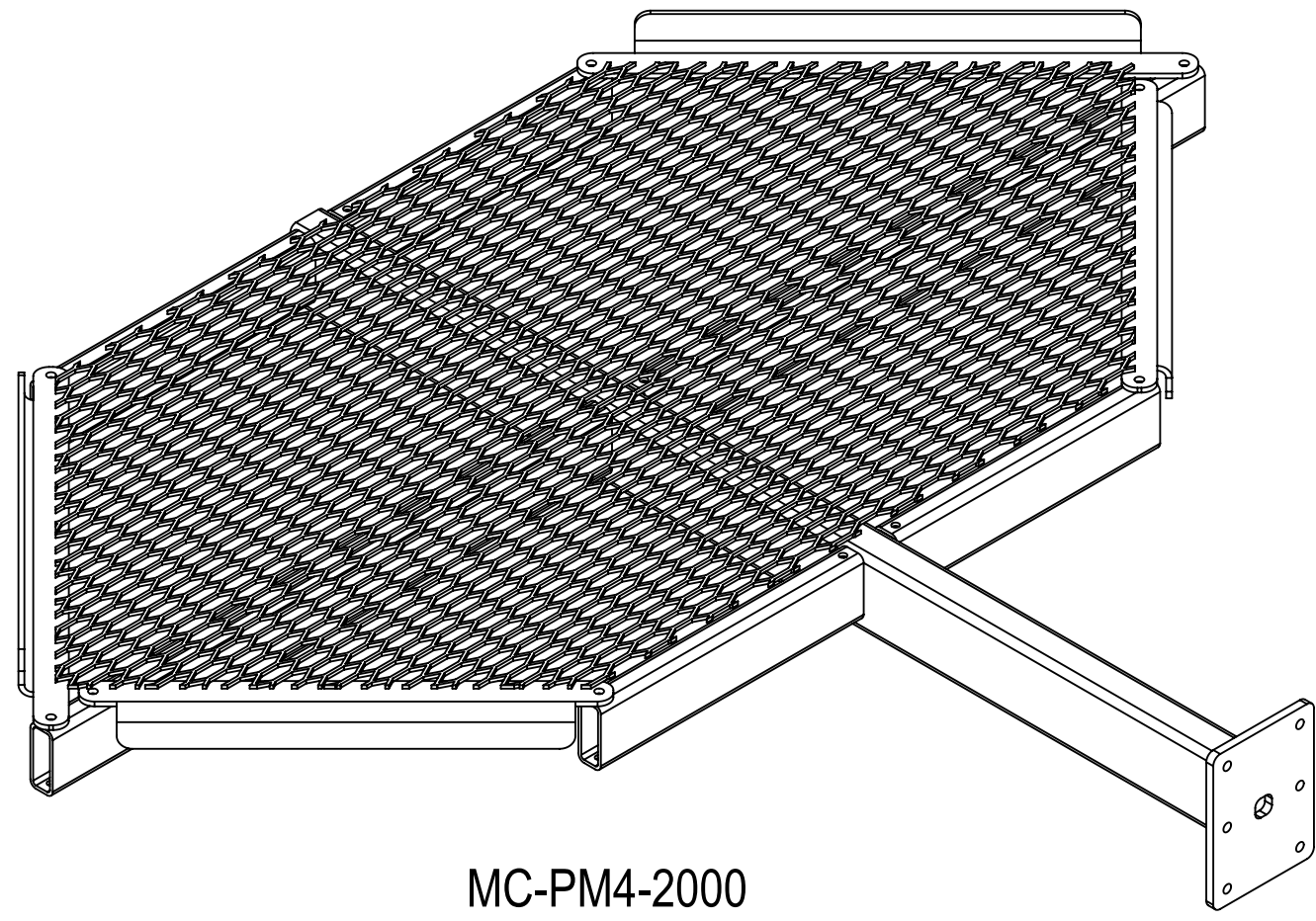

MC-PM4-2000

16X

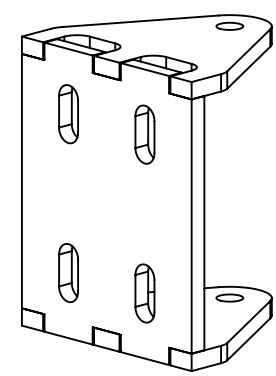

MCPM-2005-00

16X

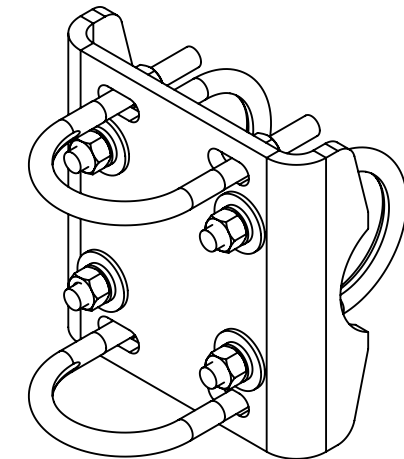

MT-219N-H

32X

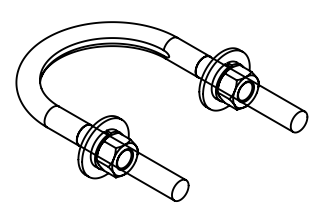

GUB-4352

32X

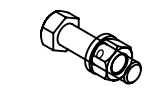

GB-04205

24X

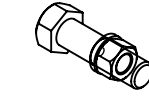

GB-0524A

4X

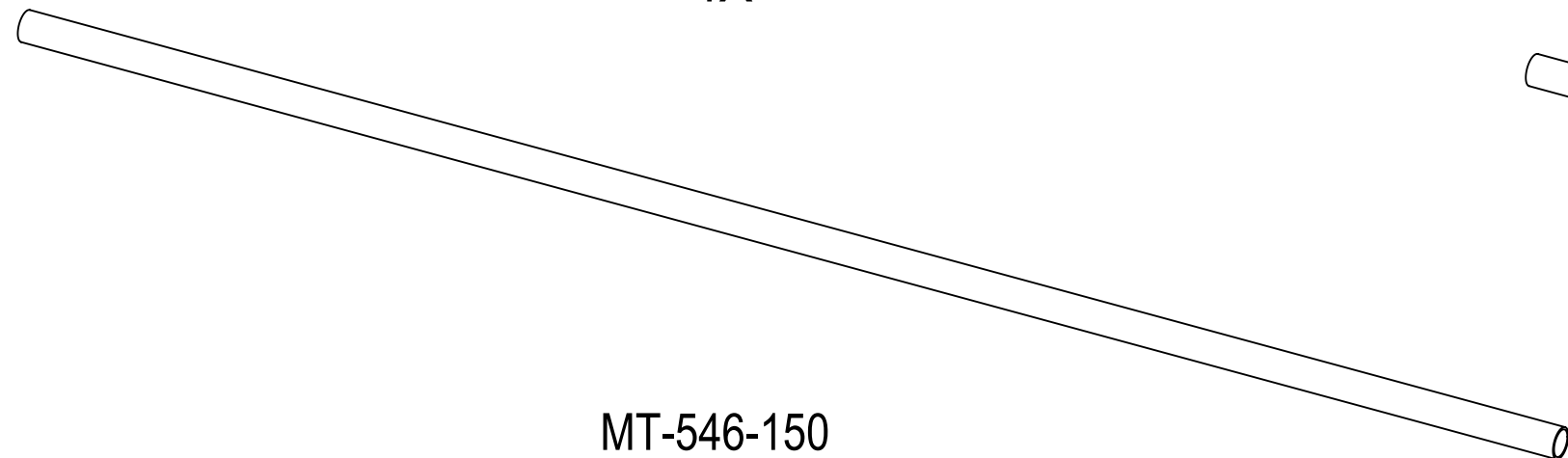

MT-546-150

16X

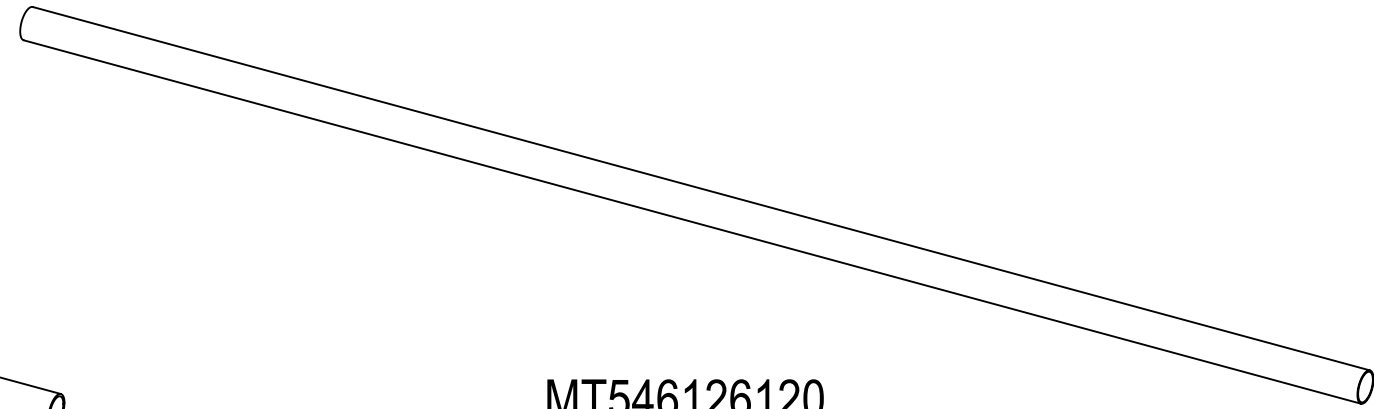

MT546126120

COMMSCOPE, INC. OF NORTH CAROLINA

TITLE  
 ATLAS4, 12' FP,(16)2.88" X126"AP

SIZE <b>C</b>	SCALE <b>1:8</b>	DOCUMENT NO. MC-PM12M4-16-126
------------------	---------------------	----------------------------------

	DRAWING			SHEET 3 OF 7
	VERSION 01	STATUS RE	REVISION B	

© 2022 CommScope, Inc. Confidential

4

3

2

1

D

D

C

C

B

B

A

A

STEP 1: ATTACH RING MOUNT SECTORS(RMHD1545-4-1000) TO MONOPOLE USING THREAD RODS (MT38440) AND NUT KITS (GWL-06 & GN-06)

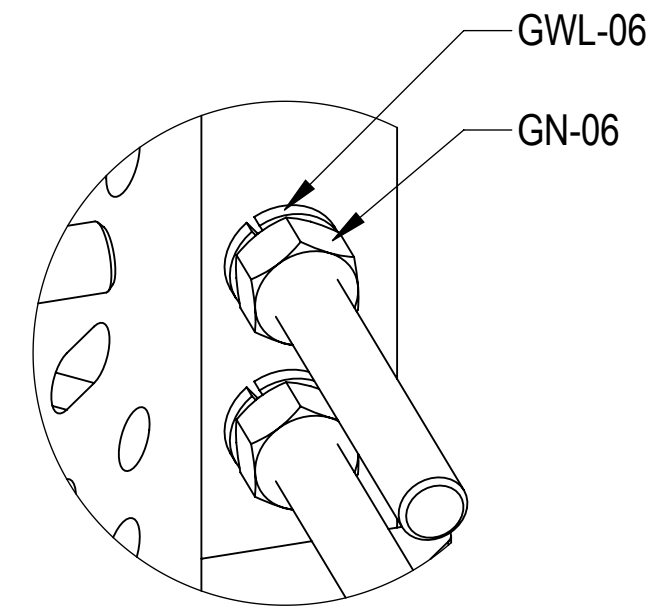
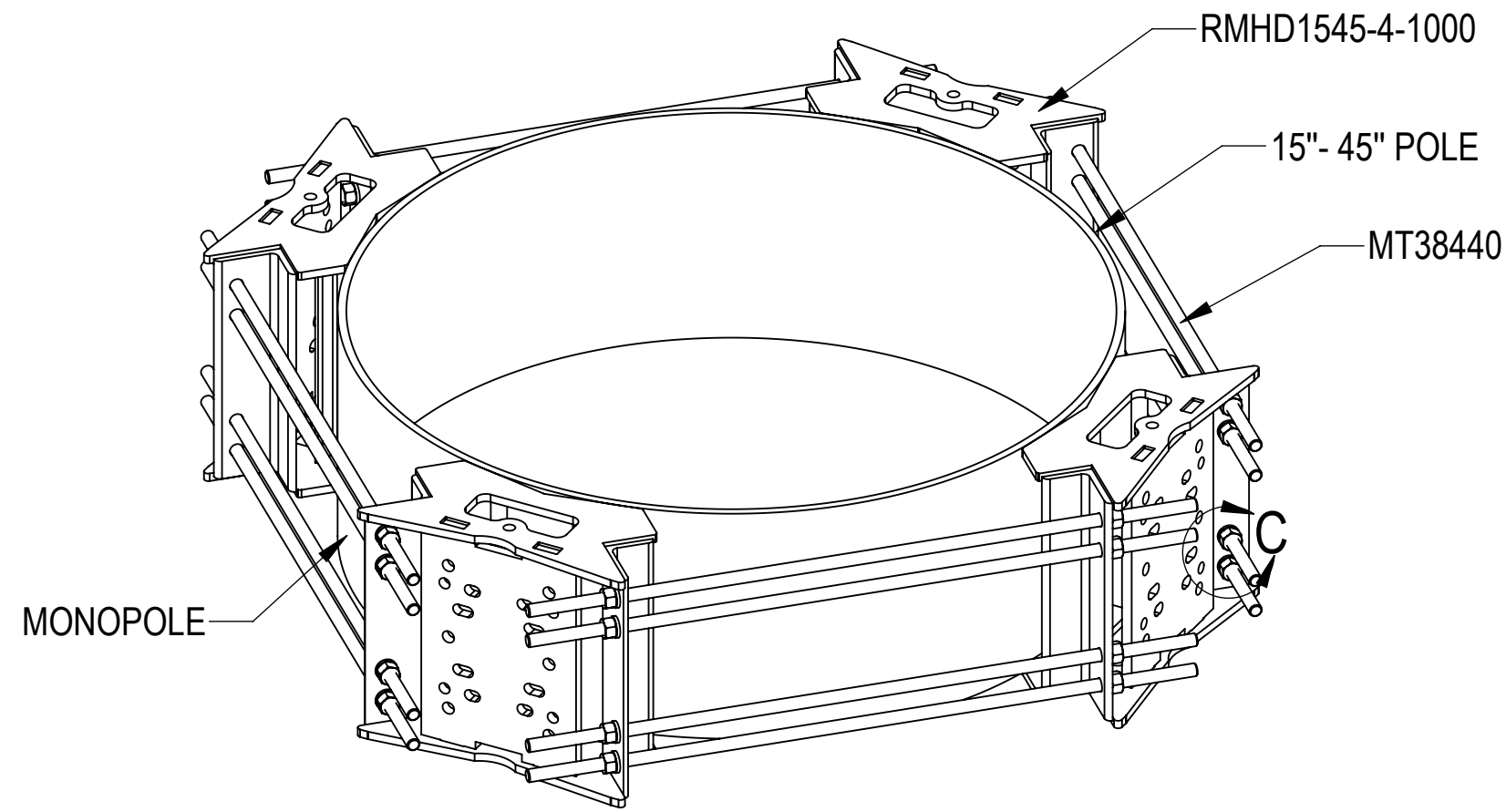

DETAIL C  
SCALE 1 : 2

STEP 2: ATTACH PIPE MOUNTING BRACKETS (MCPM-2005-00) TO T-ARMS (MC-PM4-2000) USING BOLT KITS (GB-04205)

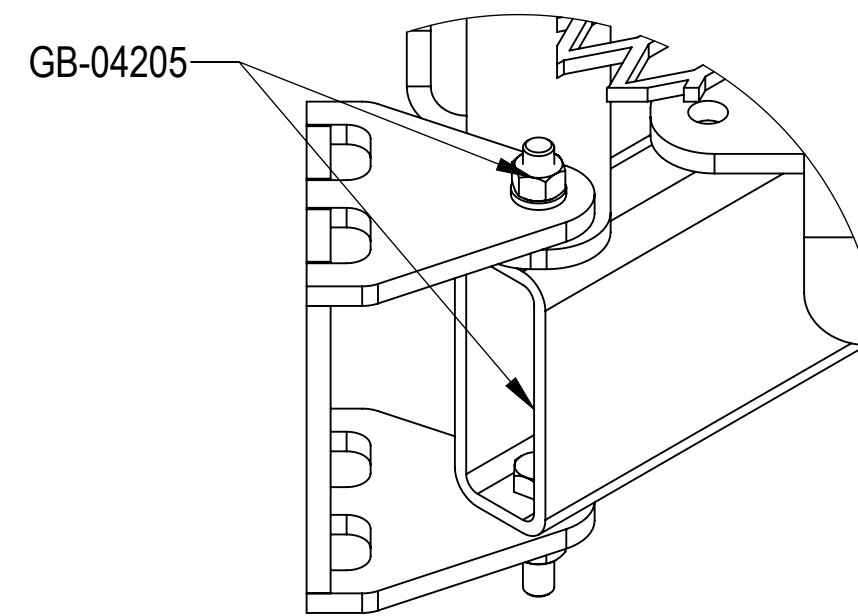
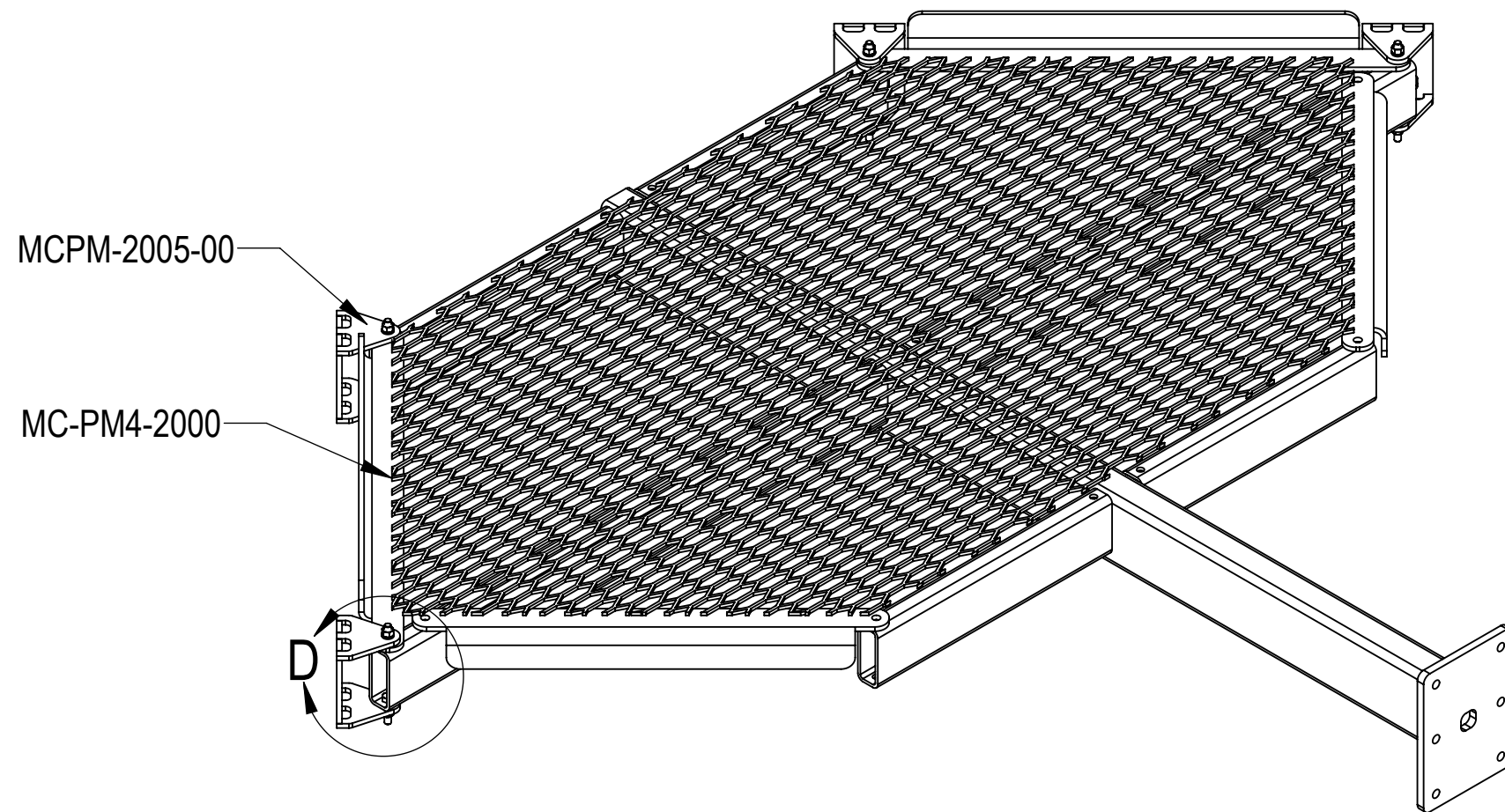

DETAIL D  
SCALE 1 : 3

COMMSCOPE, INC. OF NORTH CAROLINA				
TITLE ATLAS4, 12' FP,(16)2.88" X126"AP				
SIZE <b>C</b>	SCALE <b>1:48</b>	DOCUMENT NO. MC-PM12M4-16-126		
		DRAWING		SHEET
		VERSION	STATUS	REVISION
		01	RE	B
				4 OF 7



STEP 3: ATTACH T-ARMS (MC-PM4-2000) TO RING MOUNT (MC-RMHD-1545-4) USING BOLT KITS (GB-0524A)

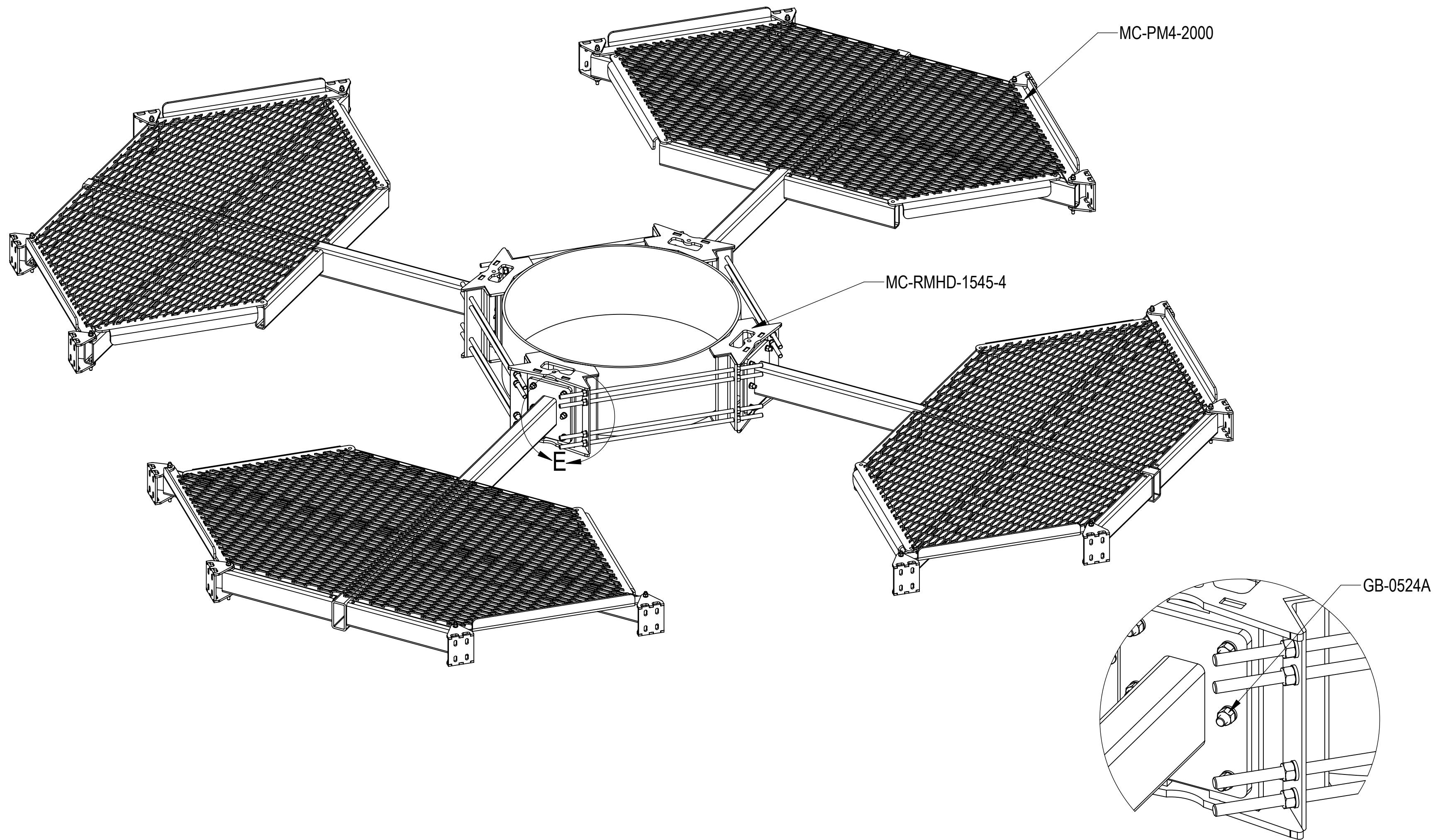

**DETAIL E**  
SCALE 1 : 5

COMMSCOPE, INC. OF NORTH CAROLINA				
TITLE ATLAS4, 12' FP,(16)2.88" X126"AP				
SIZE <b>C</b>	SCALE <b>1:48</b>	DOCUMENT NO. MC-PM12M4-16-126		
		DRAWING		SHEET
		VERSION	STATUS	REVISION
		01	RE	B
				SHEET 5 OF 7

STEP 4: ATTACH FACE PIPES (MT-546-150) TO T-ARMS (MC-PM4-2000) USING U-BOLT KITS (GUB-4352)

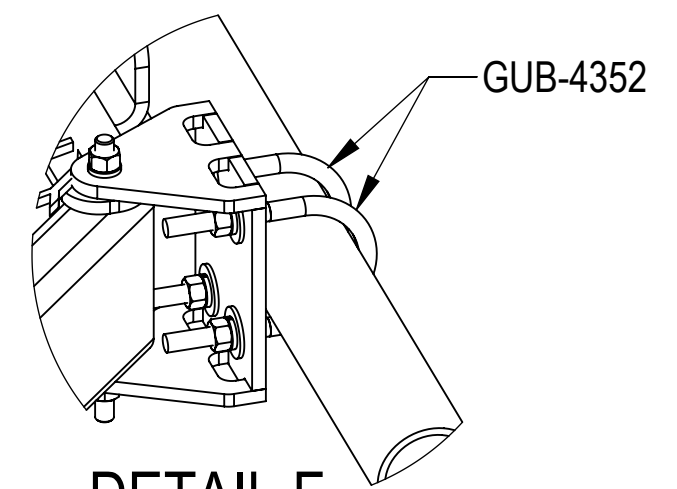
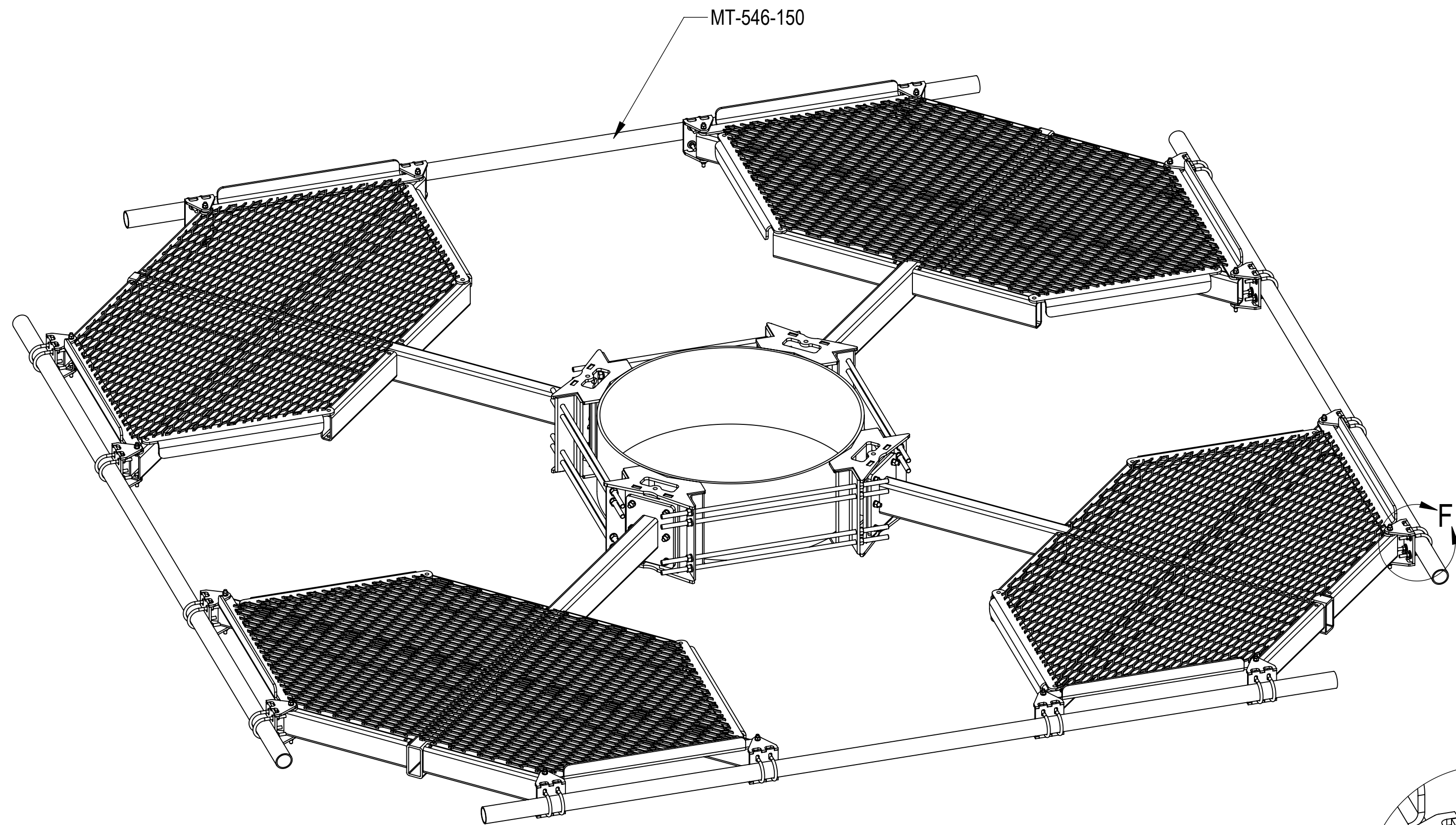

DETAIL F  
SCALE 1 : 5

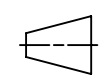
COMMSCOPE, INC. OF NORTH CAROLINA					
TITLE ATLAS4, 12' FP,(16)2.88" X126"AP					
SIZE C	SCALE 1:48	DOCUMENT NO. MC-PM12M4-16-126			
 		DRAWING			SHEET 6 OF 7
		VERSION 01	STATUS RE	REVISION B	

STEP 5: ATTACH ANT PIPES (MT546126120) TO FACE PIPES (MT-546-150) USING SADDLE PIPE MOUNTING PLATES (MT-219N-H)

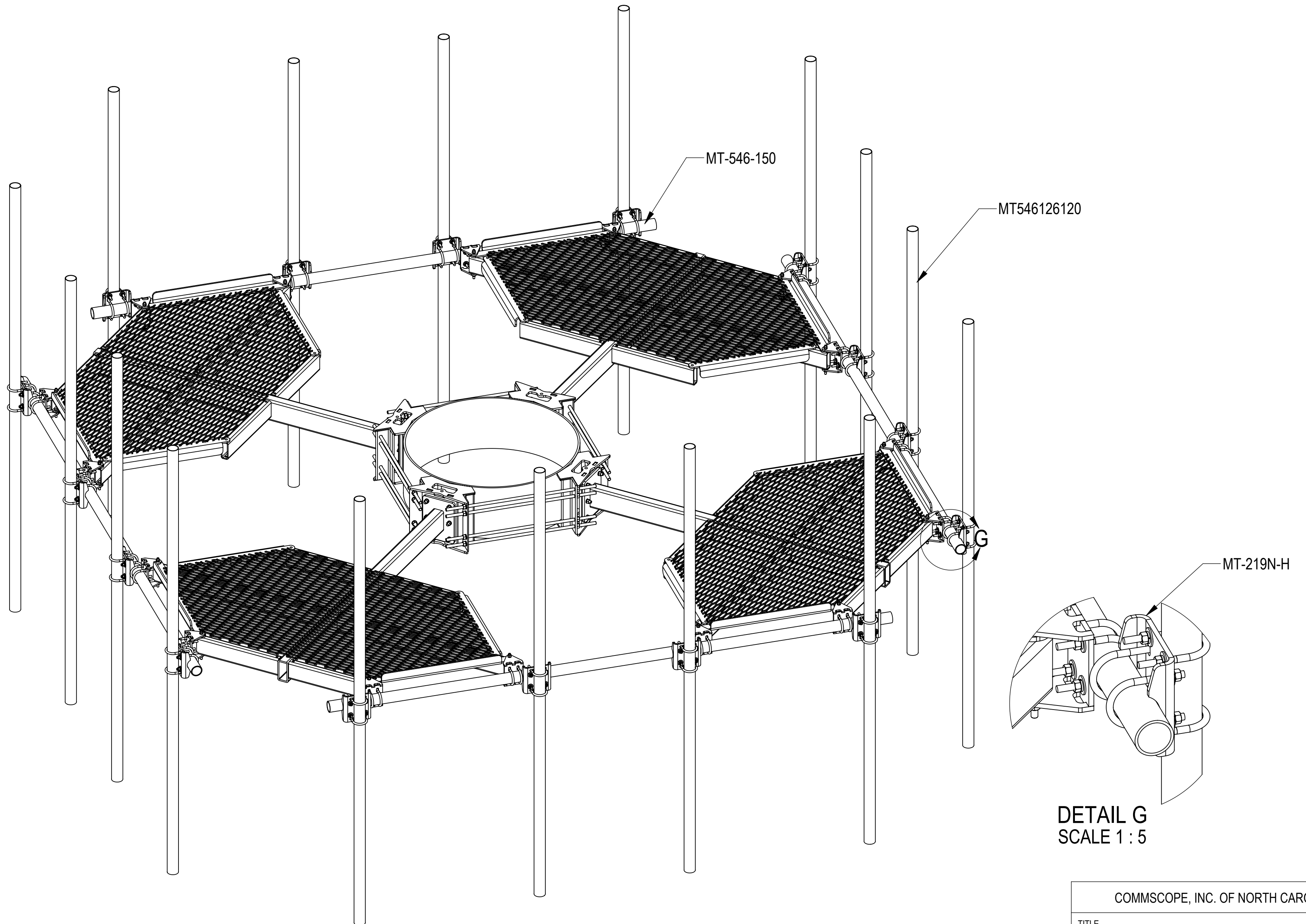

DETAIL G  
SCALE 1 : 5

COMMSCOPE, INC. OF NORTH CAROLINA				
TITLE ATLAS4, 12' FP,(16)2.88" X126"AP				
SIZE <b>C</b>	SCALE <b>1:48</b>	DOCUMENT NO. MC-PM12M4-16-126		
		DRAWING		SHEET
		VERSION	STATUS	REVISION
		01	RE	B
				7 OF 7