

- 1.0 GENERAL NOTES
 1.1 ALL METRIC DIMENSIONS ARE IN BRACKETS [X.X]
 1.2 FOR PATENT INFO: <https://www.cs-pat.com>
 2.0 DESIGN NOTES
 2.1 USE DRAWING MC-RMHD-1545-4 TO ASSEMBLE RING MOUNT
 2.2 ANY HAZARDS OR OBSTRUCTIONS TO THE CLIMBING FACILITY AND SAFETY CLIMB MUST BE IDENTIFIED PRIOR TO INSTALLING THE APPURTENANCE. ADDITIONAL PRODUCTS MAY BE REQUIRED TO MAINTAIN THE INTEGRITY OF THE SAFETY CLIMB. DURING INSTALLATION, TEMPORARY AND/OR PERMANENT PRECAUTIONARY MEASURES SHOULD BE TAKEN TO PRESERVE THE CLIMBING FACILITY AND/OR SAFETY CLIMB.
 3.0 MANUFACTURING/SPECIAL REQUIREMENTS
 3.1 TIGHTEN ALL BOLTS SECURING FLAT PLATES BY THE TURN-OF-NUT METHOD. TIGHTEN ALL U-BOLTS USING TURN-OF-NUT METHOD WITH ATTENTION TO LEAVE EQUAL DISTANCE AND EQUAL FORCE ON EACH LEG OF THE U-BOLT.
 4.0 TEST
 5.0 PACKAGING
 5.1 PACKAGING SHALL MEET COMMSCOPE REQUIREMENTS PER DOCUMENT IS-PL-3005
 5.2 PRINTED DOCUMENT TO BE PLACED INSIDE POLYBAG AND THEN IN SHIPPING CONTAINER
 5.3 EXTRA HARDWARE MAYBE SUPPLIED, BAGGED AND SHIPPED

REVISIONS			
REV.	DESCRIPTION	DATE	APPROVED
A	INITIAL RELEASE	YMENG 20OCT21	BA1025 14658
B	MCPM-2005-00 WAS MCPM-2000-00, MT-219N-H WAS MT21703 KIT, GB-0524A WAS GB-0522A, ALL U-BOLTS CHANGED TO GUB-4352	YMENG 08OCT22	BA1025 40156827CMO

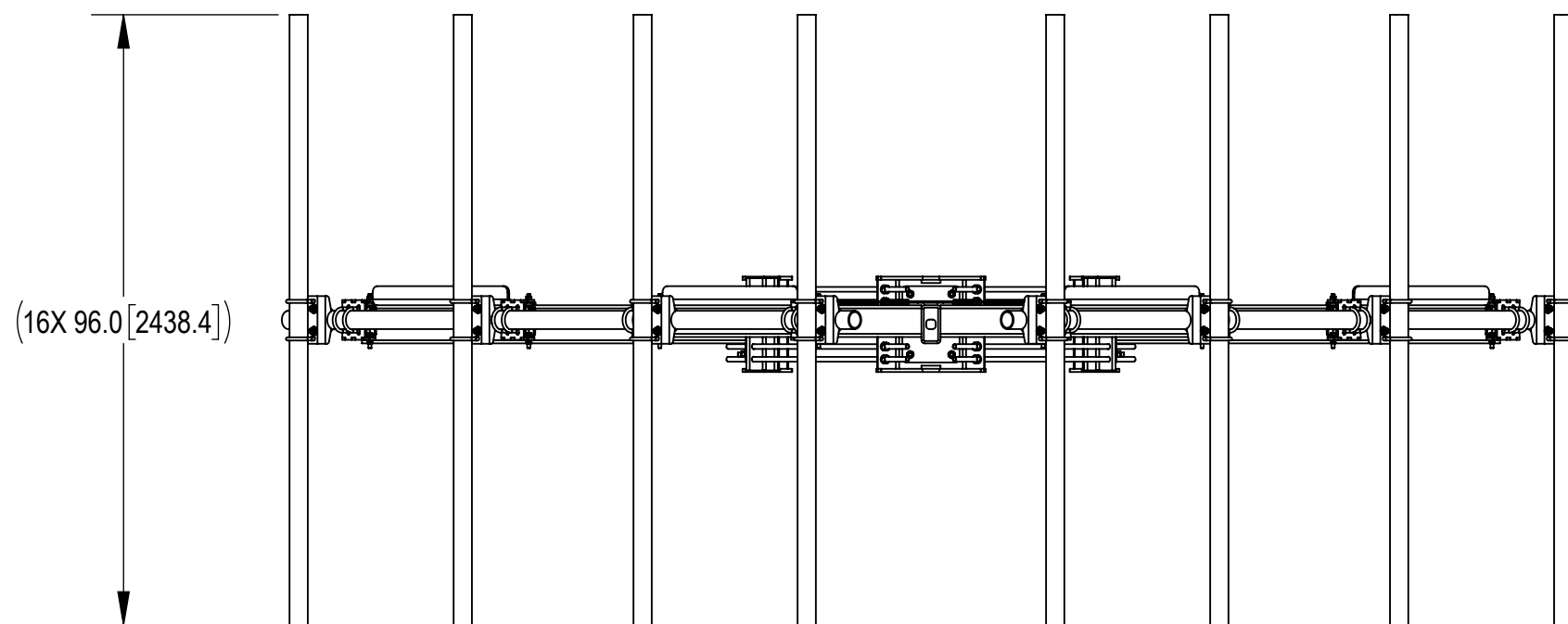
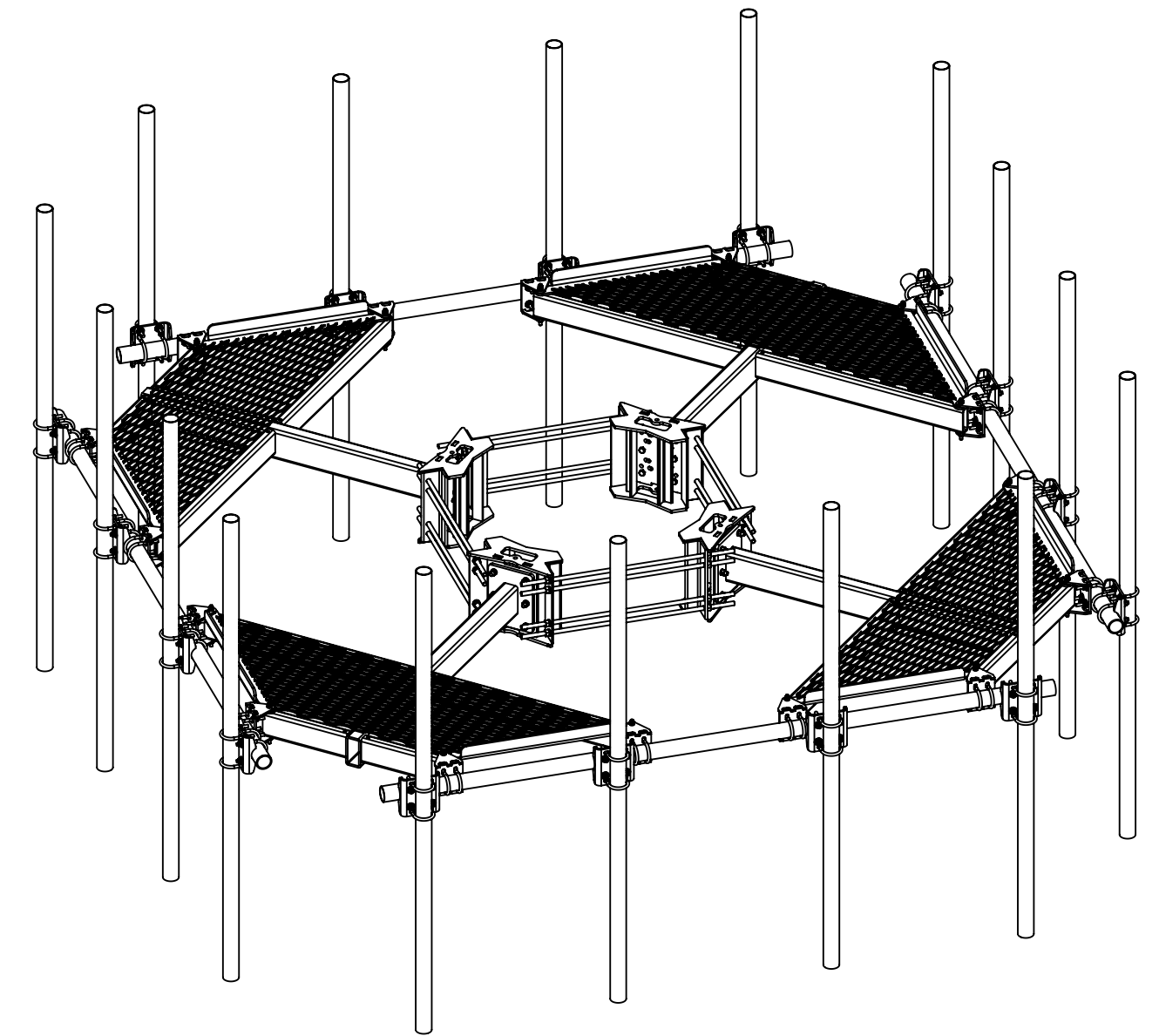
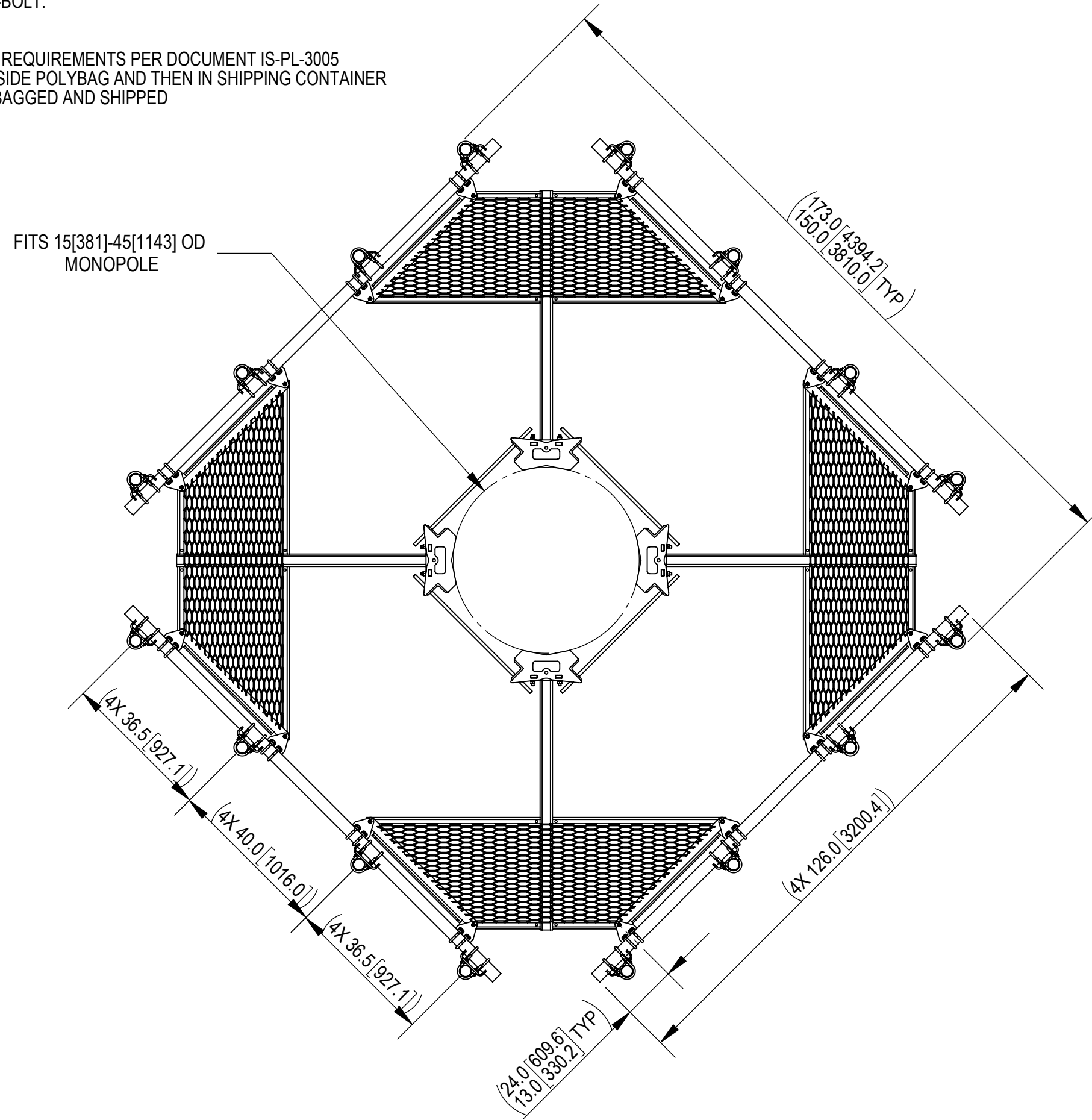

DENSITY	2545.92	lbs/in ³
MASS	2545.92	lbs
VOLUME	10053.70	in ³
SURFACE AREA	85115.17	in ²
HEIGHT	96[2438]	
LENGTH	173[4394]	
WIDTH	173[4394]	

© 2022 CommScope, Inc. Confidential

COMMSCOPE, INC. OF NORTH CAROLINA

TOLERANCES
 1 PLACE .X[X] ± 0.25[6.3] 3 PLACE .XXX[X] ± 0.060[1.5]
 2 PLACE .XX[X] ± 0.12[3.0] ANGLES ± 2°

SAP MATERIAL MASTER
MC-PM10M4-16-96

FINISH: _____ MATERIAL: _____

NAME	DATE	TITLE
CE YMENG	10/20/2021	ATLAS4, 10' FP,(16)2.88" X96"AP
RW YMENG	01/10/2023	
AD MM1298	01/11/2023	
RE YMENG	01/11/2023	

SCALE: **1:48** DOCUMENT NO.: **MC-PM10M4-16-96**

ECN 40156827CMO

SIZE	Auth Group	INSL	MODEL	DRAWING			SHEET	
C			VERSION	STATUS	REVISION	VERSION	STATUS	REVISION
			01	RE	B	01	RE	B

1 OF 7

4

3

2

1

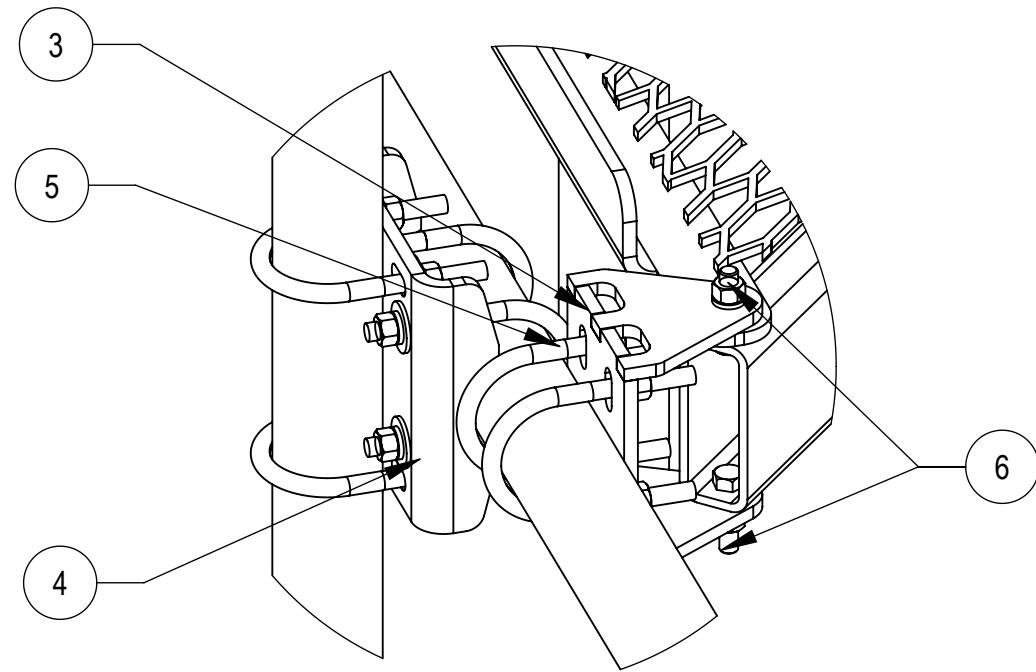

DETAIL A
SCALE 1 : 5

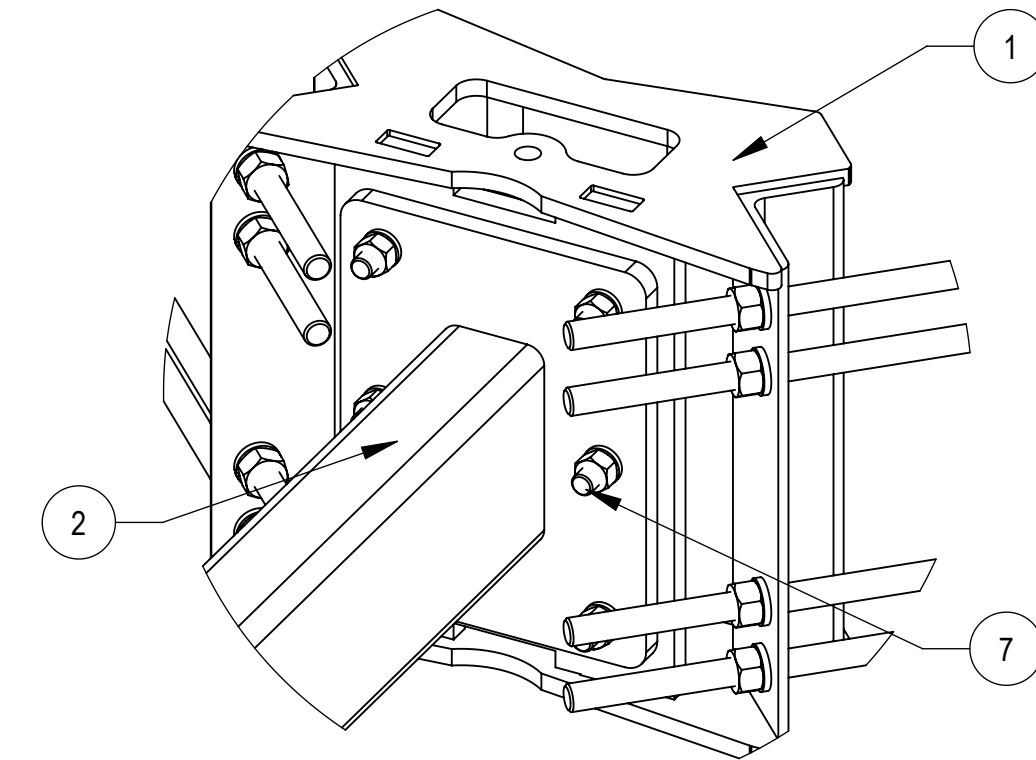

DETAIL B
SCALE 1 : 5

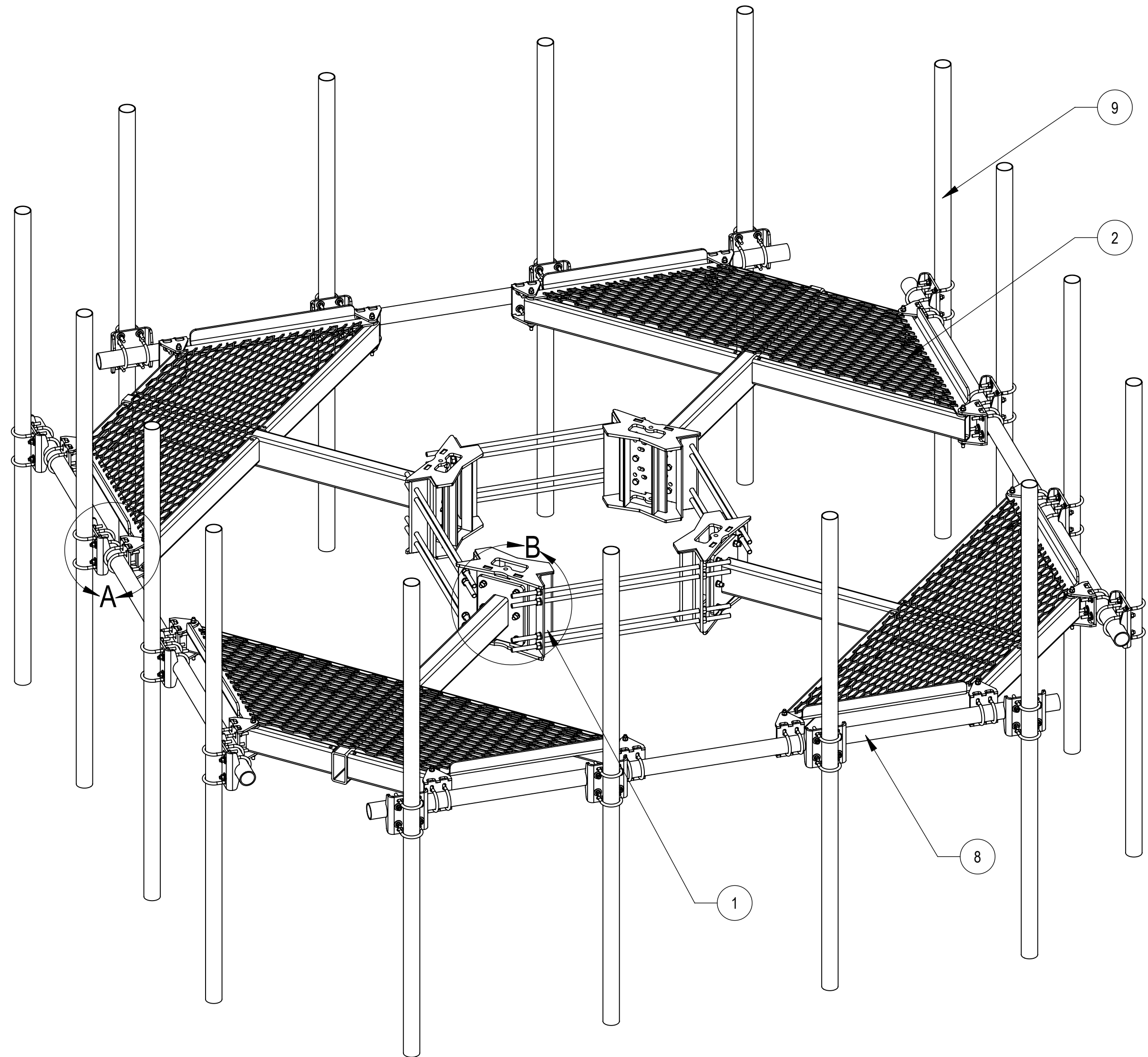

COMPONENT PART NUMBERS PROVIDED FOR ASSEMBLY PURPOSES;
INDIVIDUAL COMPONENTS MAY BE SHIPPED AS PARTS WITHIN AN INCLUDED KIT.

ITEM	PART NO.	DESCRIPTION	QTY.	WEIGHT	NOTE NO.
1	MC-RMHD-1545-4	4 SECTOR RING MOUNT, 15"-45" POLE	1	386.57LBS	
2	MC-PM4-1000	WELDMENT, CO-LOCATION PLATFORM	4	289.67 LBS	
3	MCPM-2005-00	BRACKET, PIPE MOUNTING	16	5.47 LBS	
4	MT-219N-H	SADDLE PIPE MOUNTING KIT, 2-7/8" OD	16	10.61 LBS	
5	GUB-4352	1/2" X 3" X 5-1/4" GALV U-BOLT	32	0.71 LBS	
6	GB-04205	1/2" X 2" GALV BOLT KIT	32	0.16 LBS	
7	GB-0524A	5/8" X 2-1/2" GALV BOLT KIT (A325)	24	0.30 LBS	
8	MT-546-126	PIPE, 2.875"OD X 126"	4	61.05 LBS	
9	MT54696120	PIPE, 2.875"OD X 96"	16	28.35 LBS	

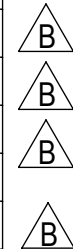

COMMSCOPE, INC. OF NORTH CAROLINA				
TITLE ATLAS4, 10' FP,(16)2.88" X96"AP				
SIZE C	SCALE 1:48	DOCUMENT NO. MC-PM10M4-16-96		
DRAWING		VERSION	STATUS	REVISION
		01	RE	B
				SHEET 2 OF 7

© 2022 CommScope, Inc. Confidential

4

3

2

1

4

3

2

1

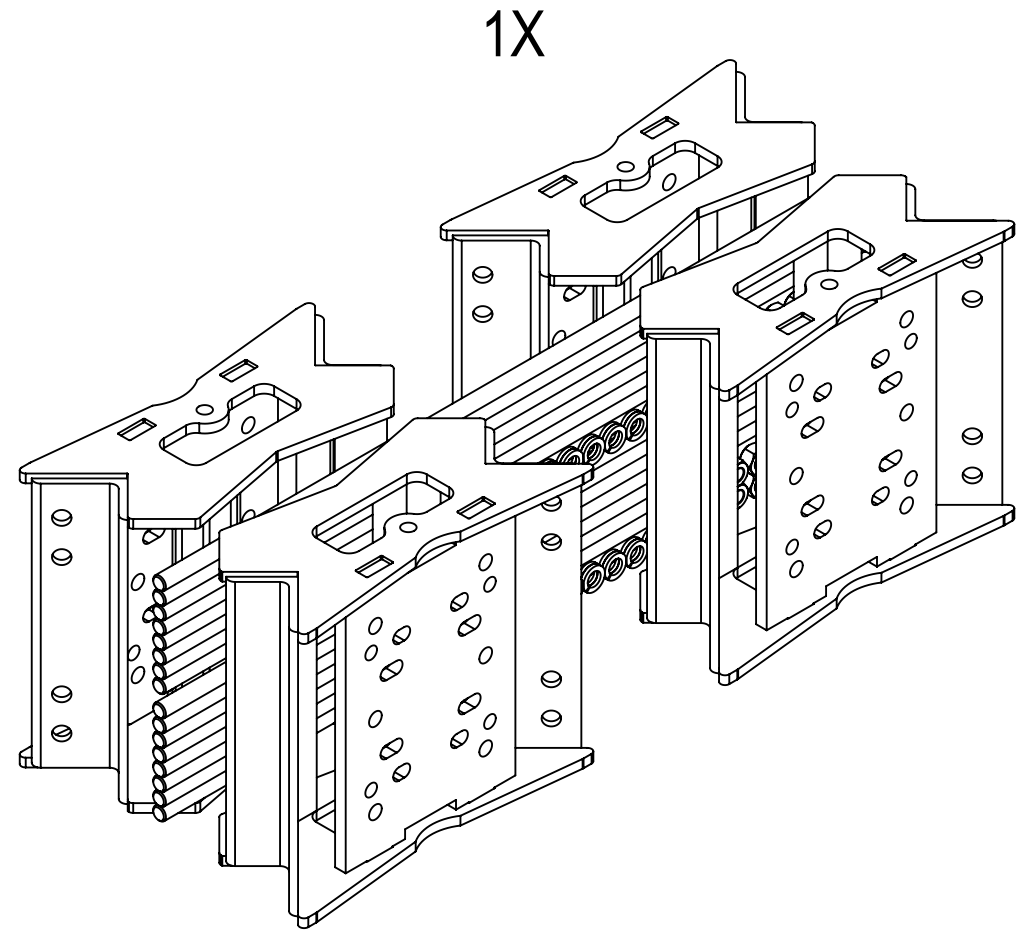

1X

MC-RMHD-1545-4

(INCLUDING 1X RMHD1545-4-1000, 16X MT38440, 32X GWL-06 AND 32X GN-06)

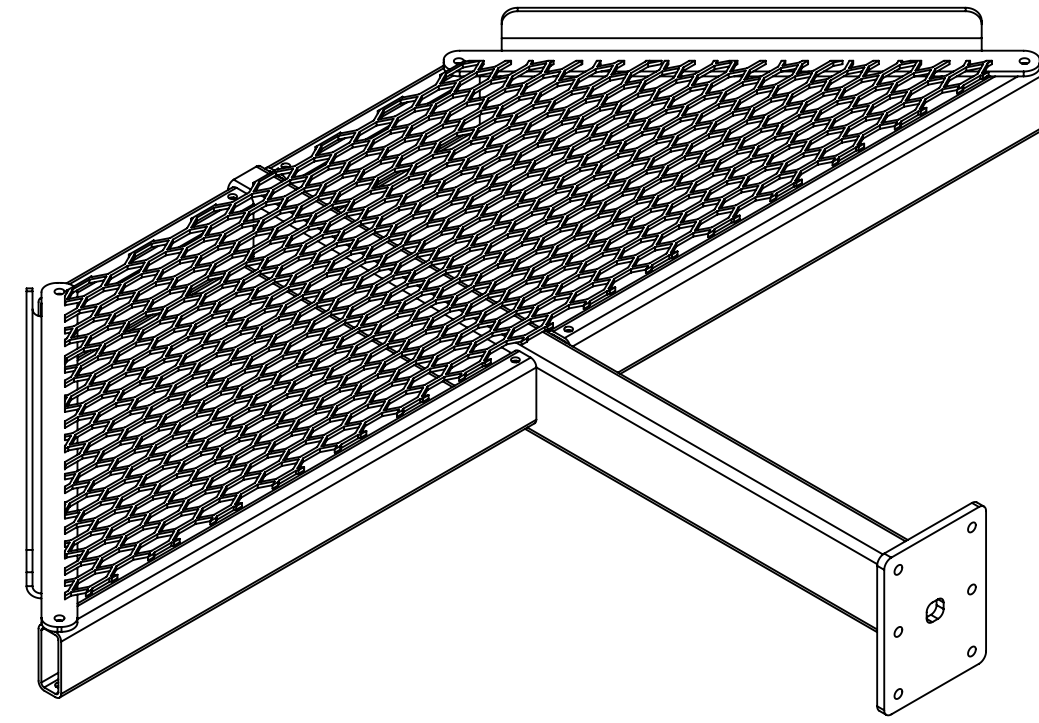

4X

MC-PM4-1000

16X

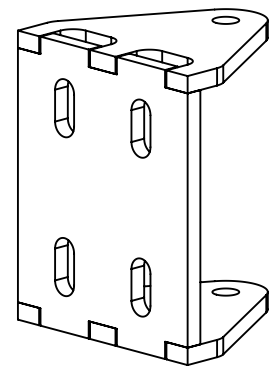

MCPM-2005-00

16X

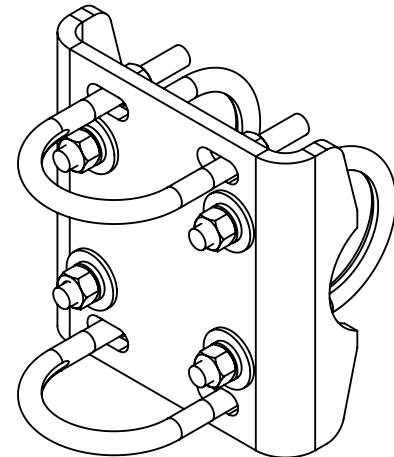

MT-219N-H

32X

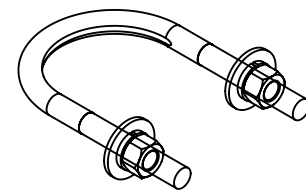

GUB-4352

32X

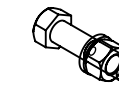

GB-04205

24X

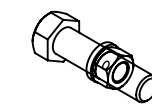

GB-0524A

4X

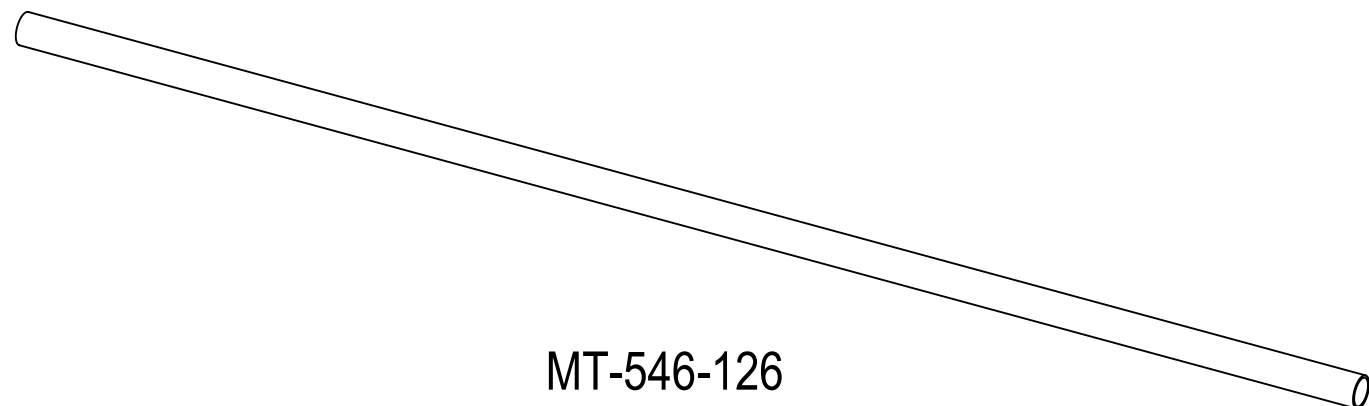

MT-546-126

16X

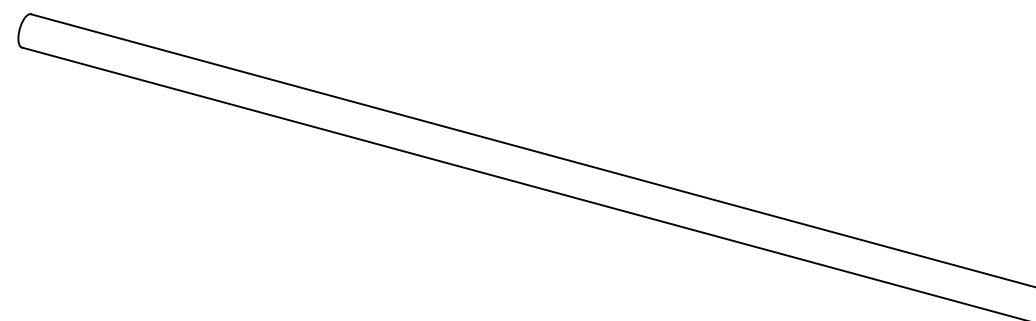

MT54696120

COMMSCOPE, INC. OF NORTH CAROLINA					
TITLE ATLAS4, 10' FP,(16)2.88" X96"AP					
SIZE C	SCALE 1:8	DOCUMENT NO. MC-PM10M4-16-96			
		DRAWING			SHEET 3 OF 7
		VERSION 01	STATUS RE	REVISION B	

© 2022 CommScope, Inc. Confidential

4

3

2

1

STEP 1: ATTACH RING MOUNT SECTORS(RMHD1545-4-1000) TO MONOPOLE USING THREAD RODS (MT38440) AND NUT KITS (GWL-06 & GN-06)

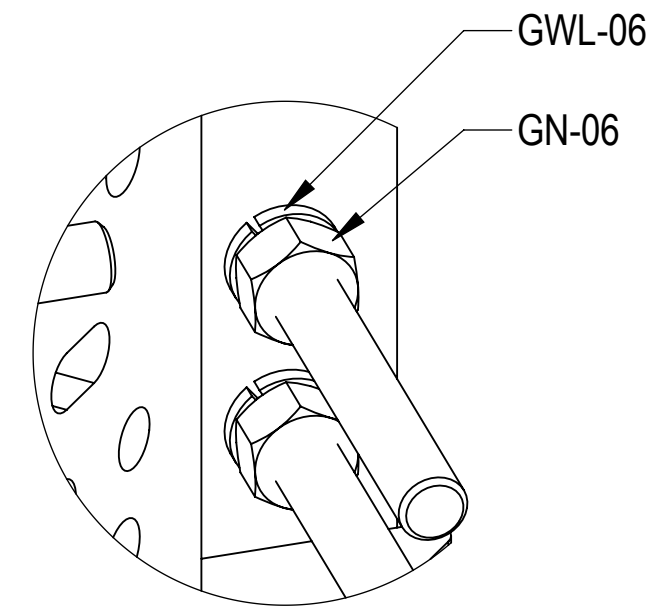
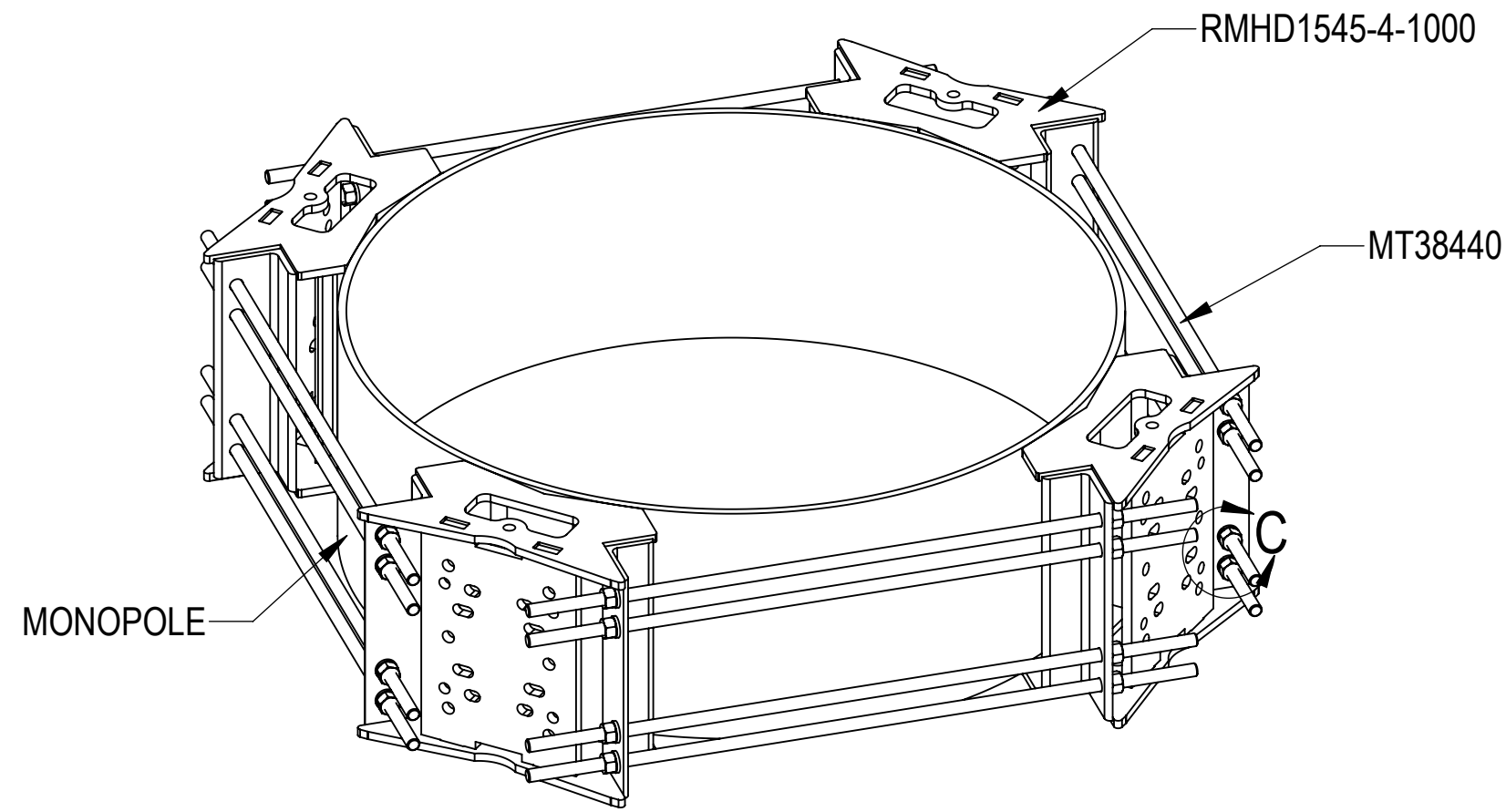

DETAIL C
SCALE 1 : 2

STEP 2: ATTACH PIPE MOUNTING BRACKETS (MCPM-2005-00) TO T-ARMS (MC-PM4-1000) USING BOLT KITS (GB-04205)

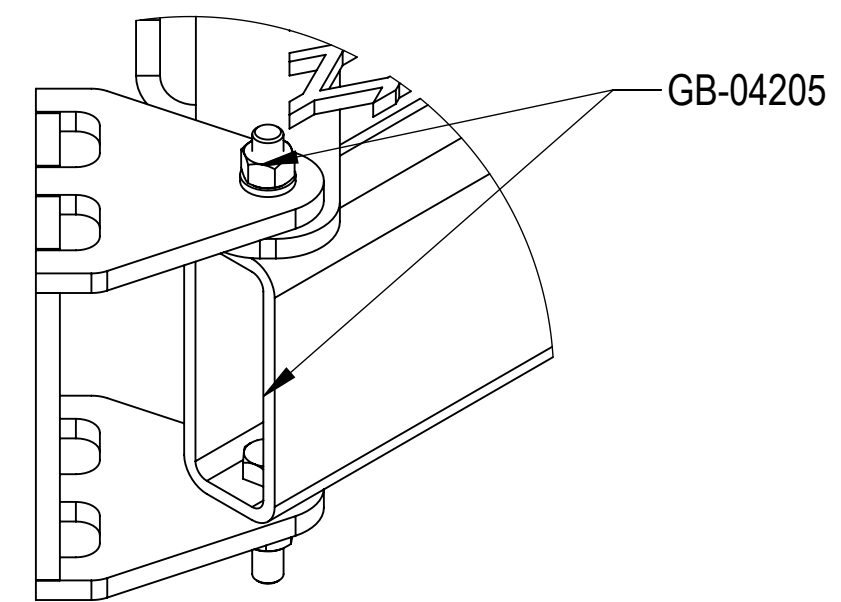
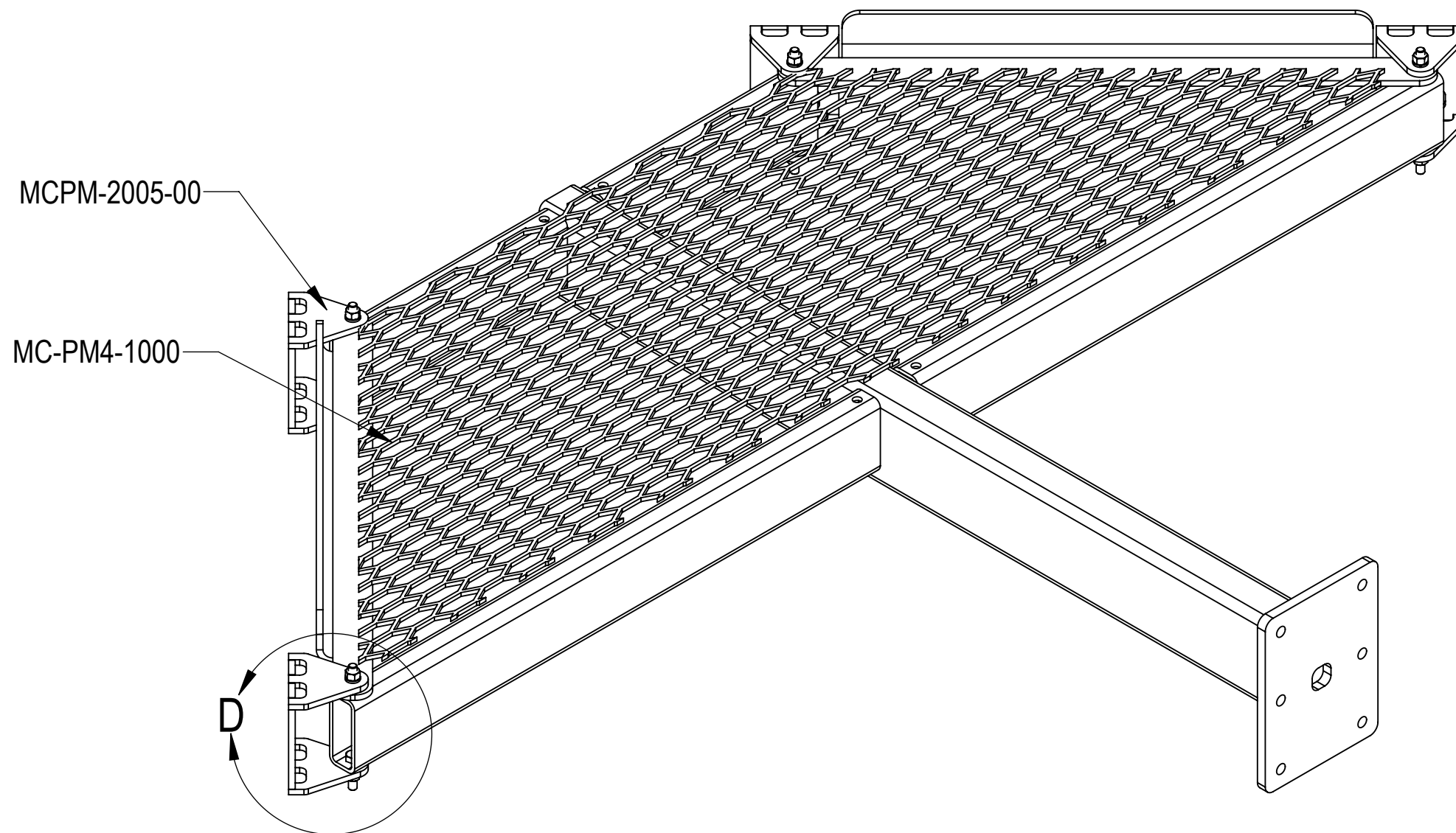

DETAIL D
SCALE 1 : 3

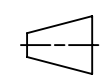
COMMSCOPE, INC. OF NORTH CAROLINA				
TITLE ATLAS4, 10' FP,(16)2.88" X96"AP				
SIZE C	SCALE 1:48	DOCUMENT NO. MC-PM10M4-16-96		
 		DRAWING		SHEET
		VERSION 01	STATUS RE	REVISION B

STEP 3: ATTACH T-ARMS (MC-PM4-1000) TO RING MOUNT (MC-RMHD-1545-4) USING BOLT KITS (GB-0524A)

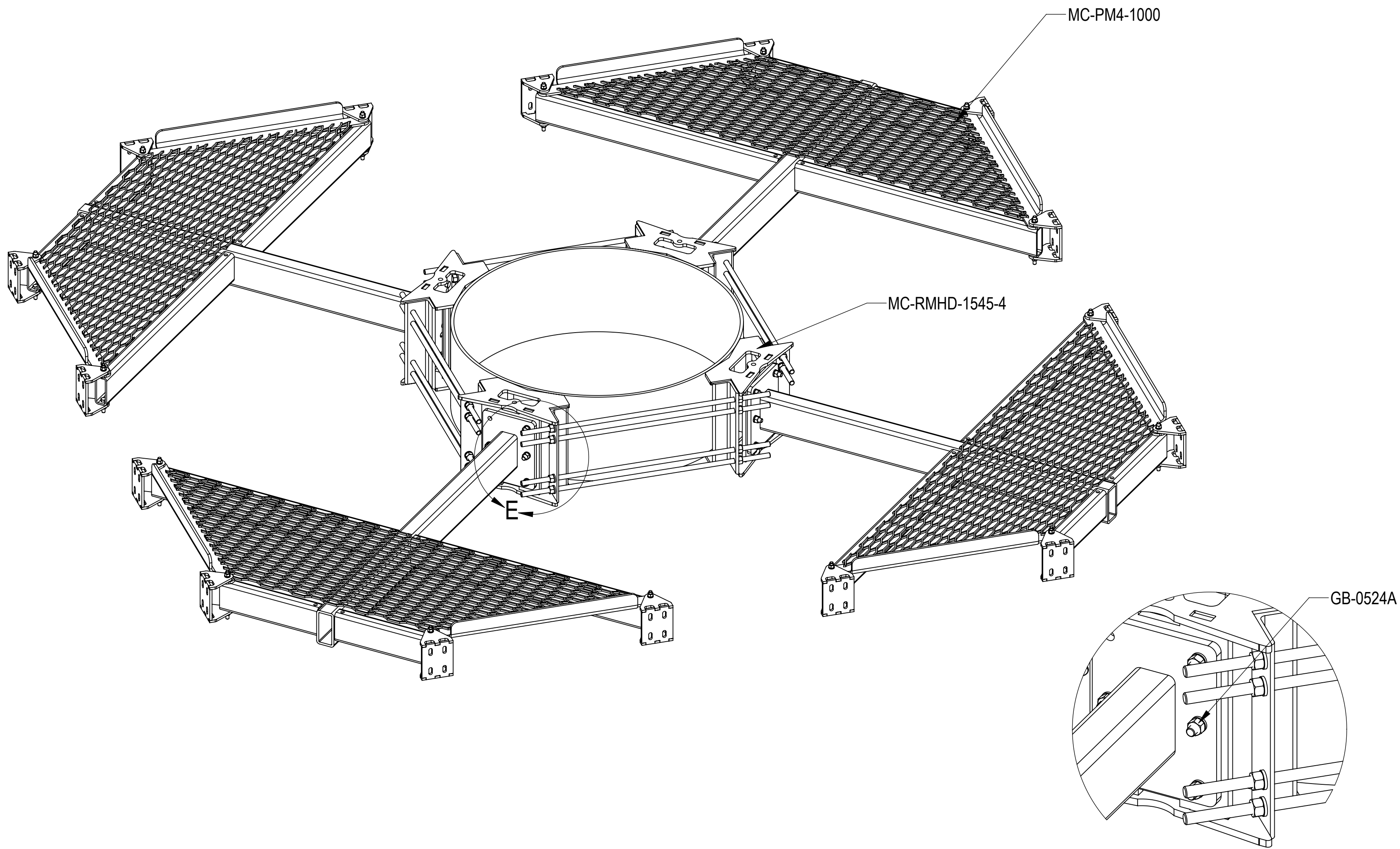



DETAIL E
SCALE 1 : 5

COMMSCOPE, INC. OF NORTH CAROLINA				
TITLE ATLAS4, 10' FP,(16)2.88" X96"AP				
SIZE C	SCALE 1:48	DOCUMENT NO. MC-PM10M4-16-96		
		DRAWING		SHEET
		VERSION	STATUS	REVISION
		01	RE	B
				5 OF 7

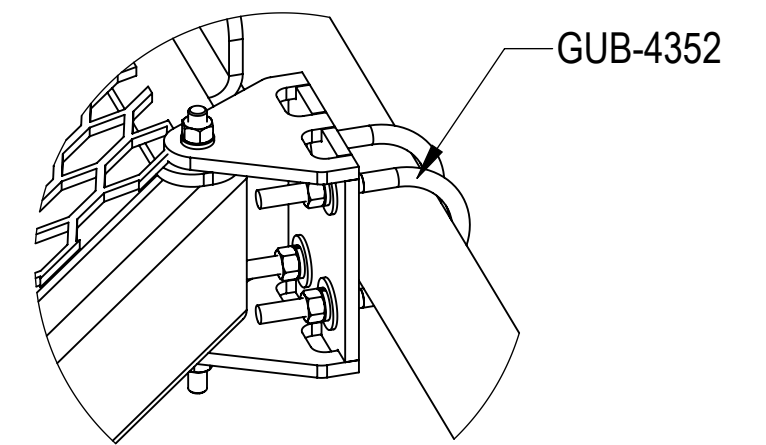
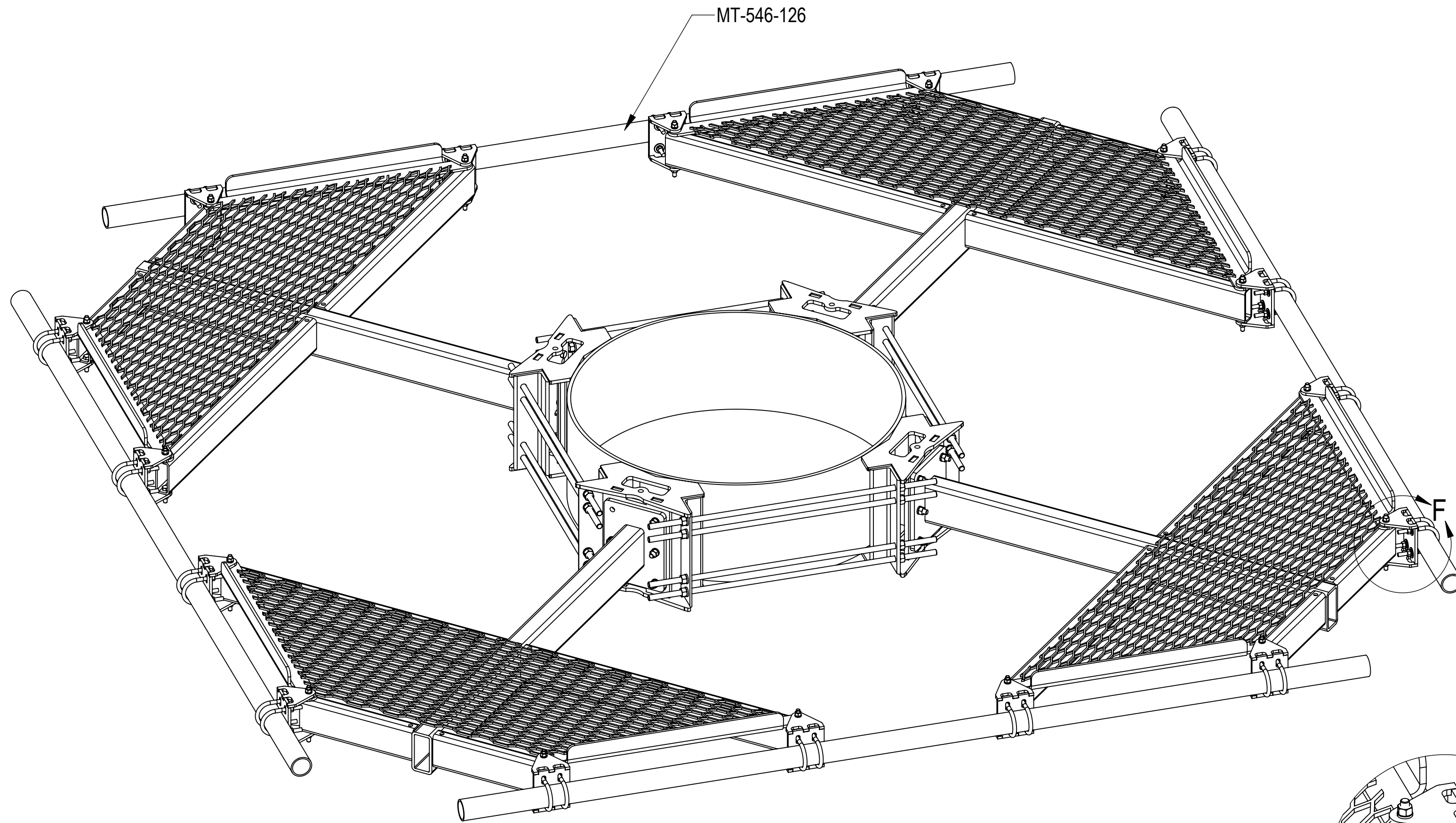
STEP 4: ATTACH FACE PIPES (MT-546-126) TO T-ARMS (MC-PM4-1000) USING U-BOLT KITS (GUB-4352)



DETAIL F
SCALE 1 : 5

COMMSCOPE, INC. OF NORTH CAROLINA					
TITLE ATLAS4, 10' FP,(16)2.88" X96"AP					
SIZE C	SCALE 1:48	DOCUMENT NO. MC-PM10M4-16-96			
 		DRAWING			SHEET 6 OF 7
		VERSION 01	STATUS RE	REVISION B	

STEP 5: ATTACH ANT PIPES (MT54696120) TO FACE PIPES (MT-546-126) USING SADDLE PIPE MOUNTING PLATES (MT-219N-H)

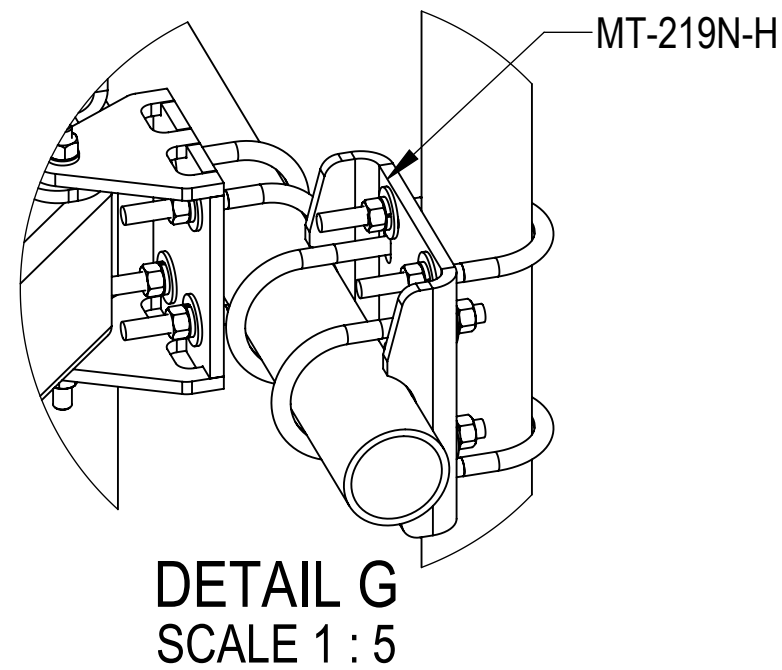
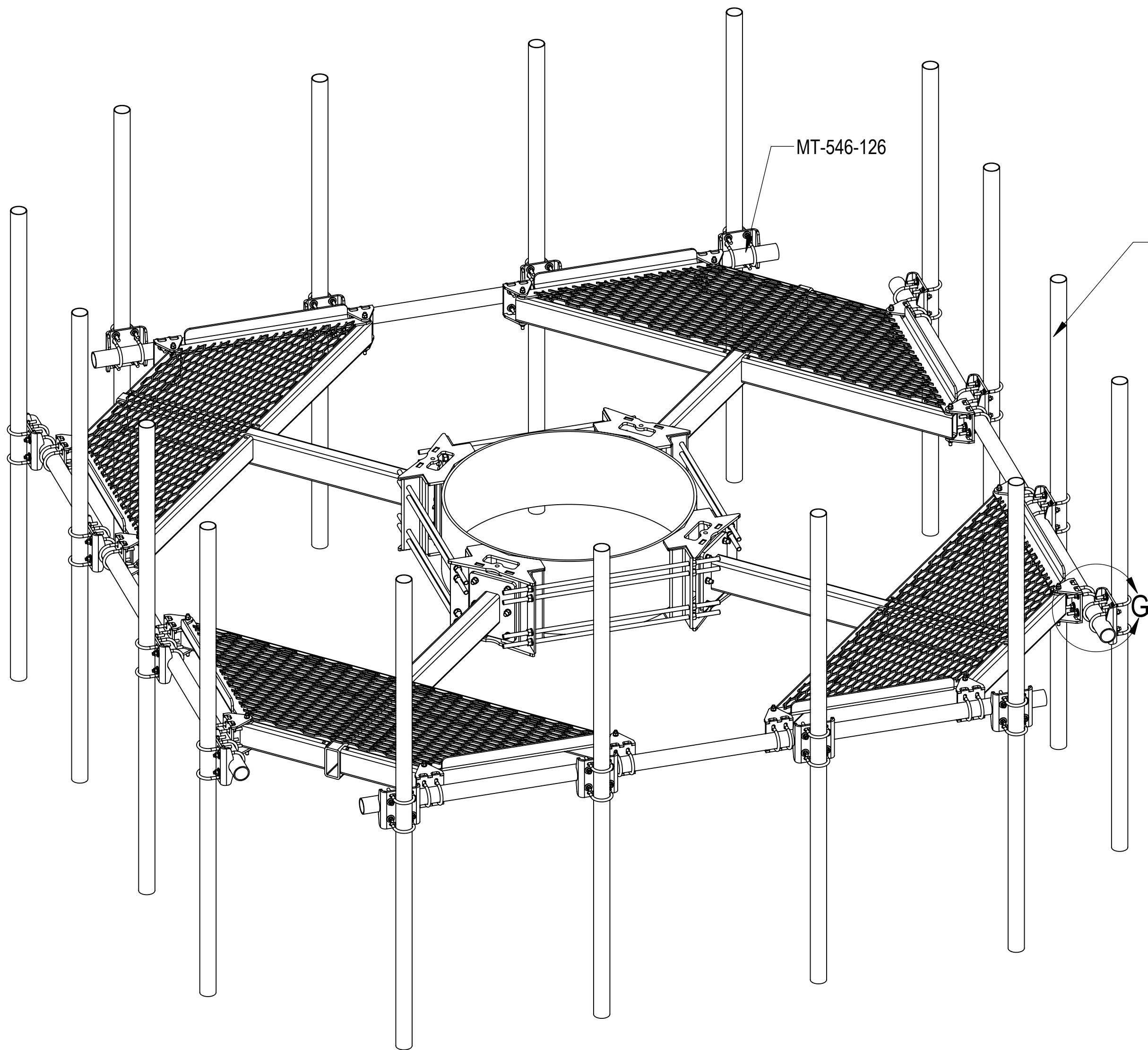

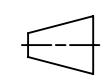
COMMSCOPE, INC. OF NORTH CAROLINA					
TITLE ATLAS4, 10' FP,(16)2.88" X96"AP					
SIZE C	SCALE 1:48	DOCUMENT NO. MC-PM10M4-16-96			
 		DRAWING			SHEET 7 OF 7
		VERSION 01	STATUS RE	REVISION B	