

- 1.0 GENERAL NOTES
 - 1.1 ALL METRIC DIMENSIONS ARE IN BRACKETS [X.X]
 - 1.2 FEATURES CRITICAL TO QUALITY ARE INDICATED IN ROUNDED BOX (X.X)
- 2.0 DESIGN NOTES
- 3.0 MANUFACTURING/SPECIAL REQUIREMENTS
 - 3.1 TIGHTEN ALL BOLTS SECURING FLAT PLATES BY THE TURN-OF-NUT METHOD.
- 4.0 TEST
- 5.0 PACKAGING
 - 5.1 PACKAGING MUST BE AGREED TO IN WRITING BY COMMSCOPE PRIOR TO MASS-PRODUCTION APPROVAL.
 - 5.2 PARTS ARE TO BE PACKAGING IN A MANNER TO PREVENT DAMAGE DURING SHIPMENT & STORAGE.
 - 5.3 PACKAGING TO ADHERE TO ALL COMMSCOPE, LOCAL & FOREIGN (WHERE APPLICABLE) SHIPPING REQUIREMENTS.
 - 5.4 PACKAGING & PARTS TO BE FREE OF ALL CONTAMINANTS INCLUDING PAPER FROM BOX, DIRT, DUST, OILS, MOLD RELEASE, DETERGENT AND ALL OTHER FOREIGN MATERIALS.

REVISIONS			
REV.	DESCRIPTION	DATE	APPROVED
A	INITIAL RELEASE	YMENG 07NOV23	XK1001 40182713CMO
B	UPDATED VIEWS FOR PGCS-1000(ITEM 1) CHANGES	JL1183 20MAY24	JX1030 40196037CMO
C	UPDATED PIPE FIT NOTE	JL1183 17JUN24	JX1030 40198252CMO
D	PGCS-8000 (ITM2) WAS PGCS-2000; PGCS-7000 (ITEM3) WAS PGCS-3000; PGCS-6000 (ITEM4) WAS PGCS-4000	JL1183 07NOV24	JX1030 40208430CMO

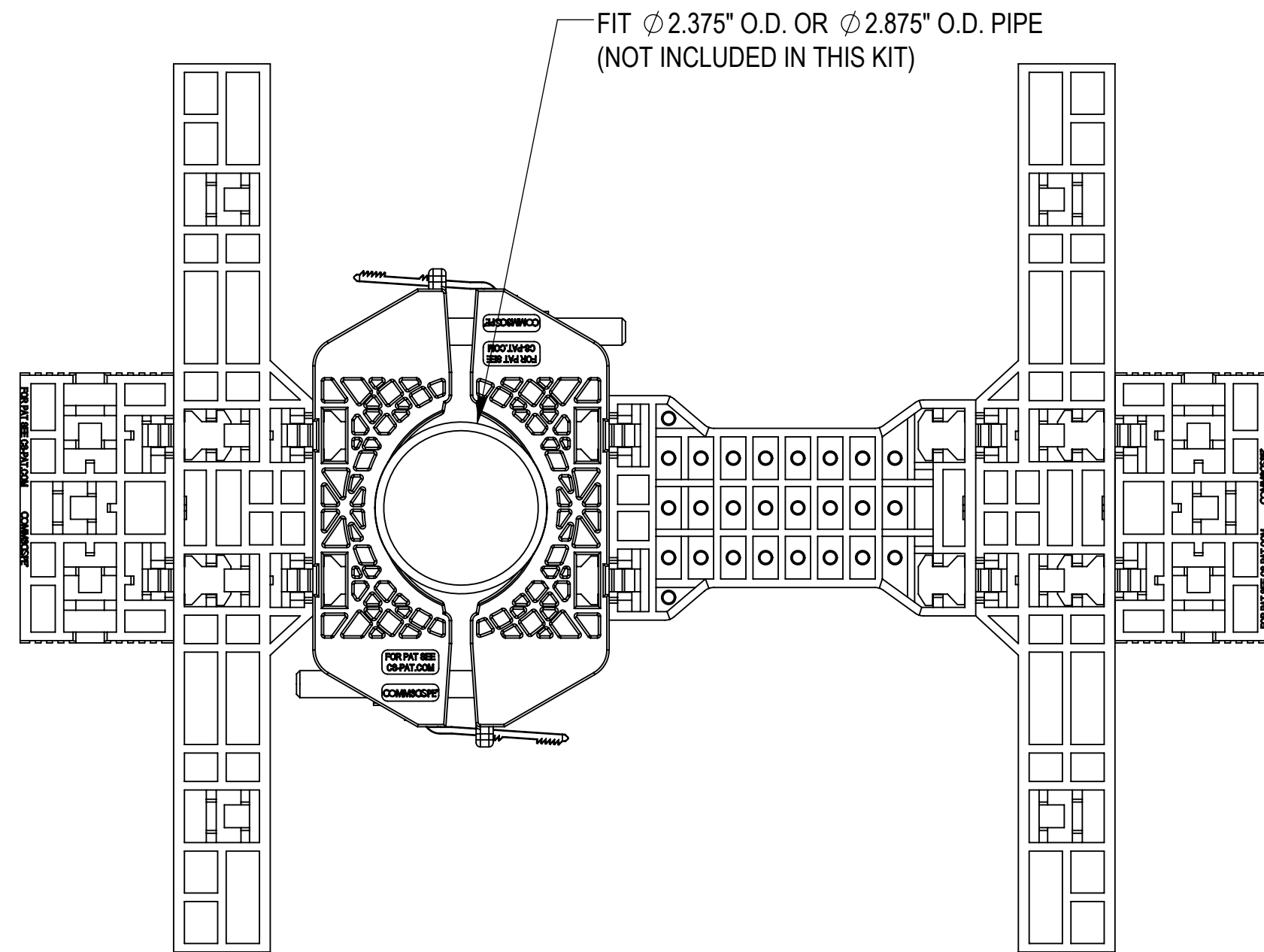

ASSEMBLY TOP VIEW

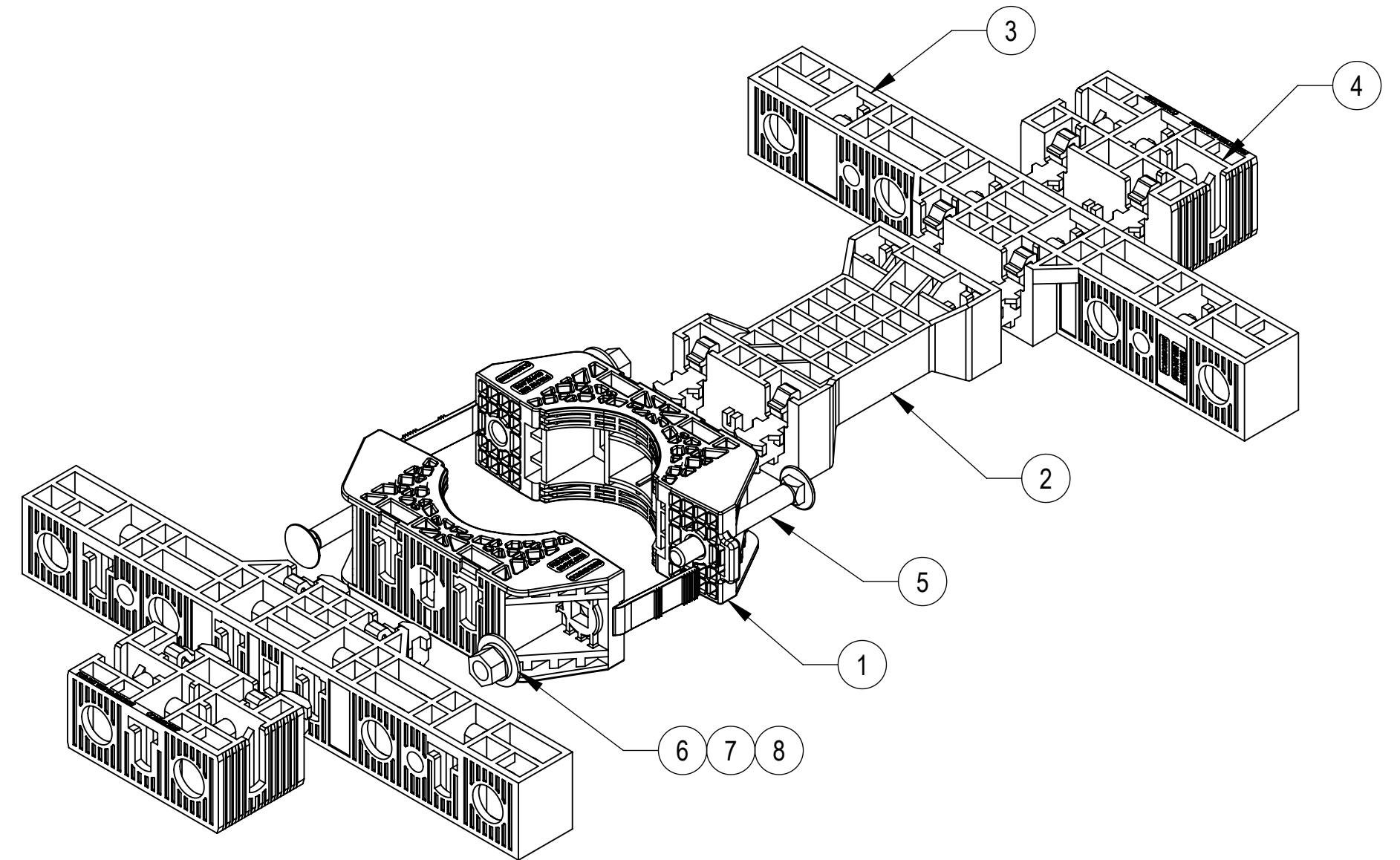

INSTALLATION ASSEMBLY

COMPONENT PART NUMBERS PROVIDED FOR ASSEMBLY PURPOSES;
INDIVIDUAL COMPONENTS MAY BE SHIPPED AS PARTS WITHIN AN INCLUDED KIT.

ITEM NO.	PART NUMBER	DESCRIPTION	QTY.	WEIGHT
1	PGCS-1000	CLAMP,FRONT-REAR, POLYMER 4CP	2	0.32 LBS
2	PGCS-8000	ADAPTER, POLYMER, 4P	1	0.19 LBS
3	PGCS-7000	PANEL, POLYMER, 8CP	2	0.33 LBS
4	PGCS-6000	ADAPTER, POLYMER, 2CP	2	0.09 LBS
5	9615-15	BOLT,CARRIAGE,3/8-16,3,STL GALV	2	0.12 LBS
6	GWF-03	3/8" FLAT WASHER	2	0.01 LBS
7	GWL-03	3/8" GALV LOCK WASHER	2	0.01 LBS
8	GN-03	3/8" GALV HEX NUT	2	0.02 LBS



DENSITY		lbs/in ³
MASS	2.42	lbs
VOLUME	58.44	in ³
SURFACE AREA	999.30	in ²
HEIGHT	2.0"	
LENGTH	17.3"	
WIDTH	12.3"	

COMMSCOPE, INC. OF NORTH CAROLINA										
TOLERANCES					SAP MATERIAL MASTER					
1 PLACE .X[X] ± 0.2[6.3]		3 PLACE .XXX[X] ± 0.060[1.5]			PGP-CS18					
2 PLACE .XX[X] ± 0.12[3.0]		ANGLES ± 2°								
FINISH					MATERIAL					
UNLESS OTHERWISE SPECIFIED DIMENSIONS ARE IN INCHES INTERPRET PER ANSI Y 14.5M-1994										
NAME		DATE		TITLE						
CE YMENG		07NOV23		PG PREMIUM,CBL-SUPPORT,18-HOLE						
RW JL1183		11/07/2024								
AD JX1030		11/17/2024								
RE JX1030		11/17/2024		SCALE		DOCUMENT NO.				
ECN 40208430CMO		1:5		PGP-CS18						
SIZE		Auth Group		INSL		MODEL		DRAWING		SHEET
C		⊕		◁		VERSION		STATUS		REVISION
02		RE		C		03		RE		D
1 OF 1										