

Installation Instructions

Connector Attachment

For Braided Cable CNT-400
Din Male, Captivated Pin, Clamp-type Body

Andrew Institute offers installation training.

Connector: 400BPDM-C

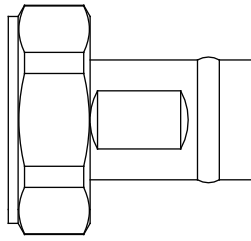

Connector Body

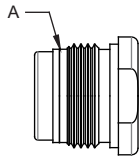

Cable Attachment

Tools



Safety Knife



Wire Brush



File

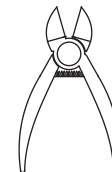

Diagonal Pliers



16 mm Wrench

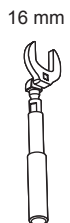

16 mm Torque Wrench

1. Straighten first 200.0 mm (7.874") min. of the cable.

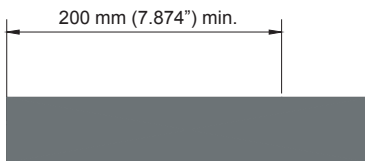

2. Remove 6.5 mm (0.256") of Jacket only.

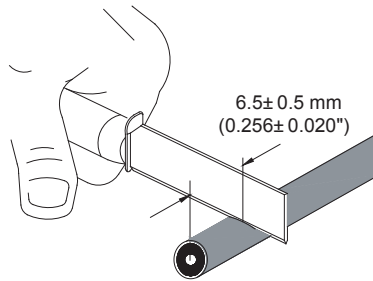

3. Comb braid straight with wire brush; Fold back braid as shown.

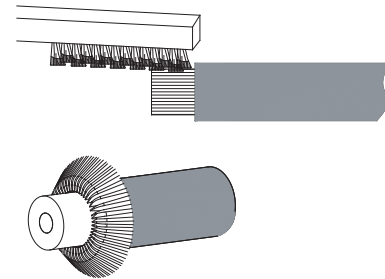

4. Remove 5.0 mm (0.197") of foil & foam, exposing the center conductor. Remove all foam/glue residue from the center conductor.

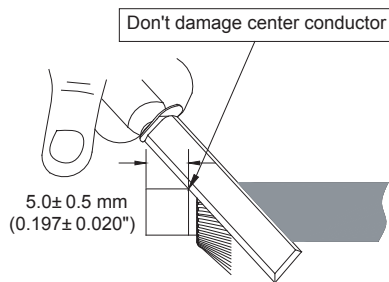

5. Taper braid towards center conductor as shown; According to illustration below to push and rotate slightly part A onto cable without damaging the braid.

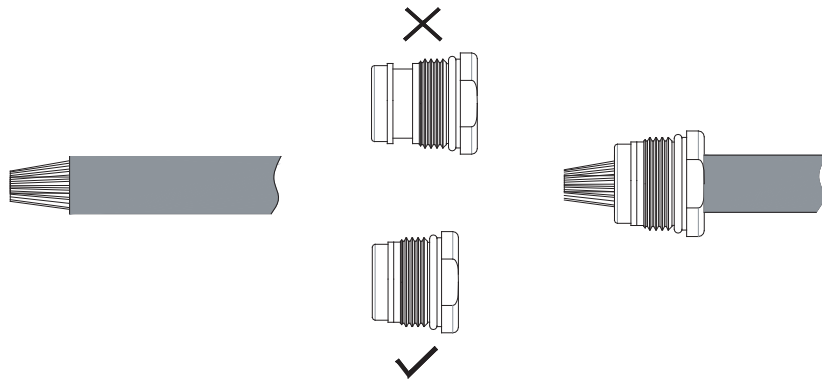

6. Fold back braid around part A and comb braid as shown, the braid should be straight and equally spaced after comb.

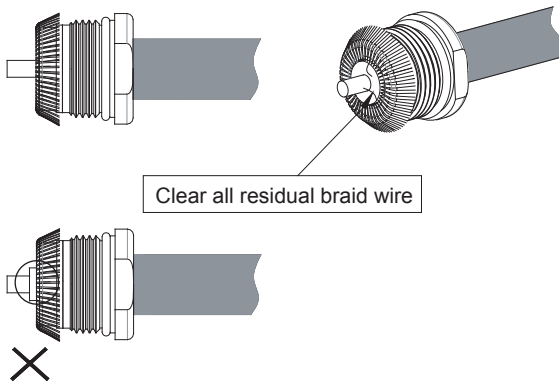

7. Cut off the redundant braid as shown.

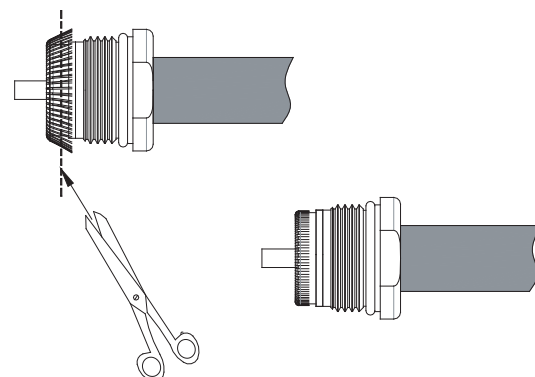

8. Chamfer the center conductor at a 45° angle.

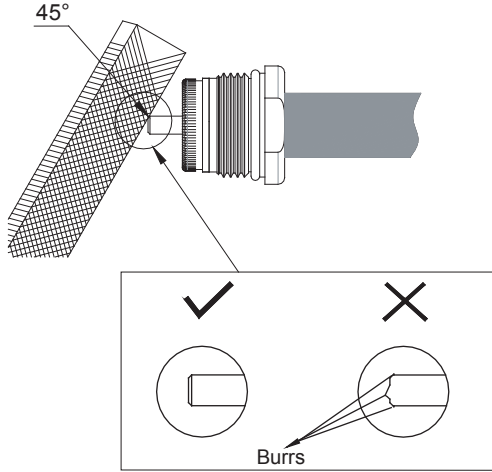

9. The cable attachment must be straight and aligned with the hole of connector inner contact; Push prepared cable attachment into the connector body until stopped; The cable center conductor must be inserted into the connector inner contact fingers.

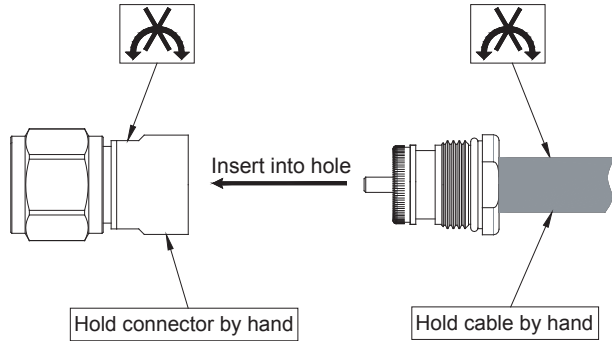

10. Tighten the connection to the torque value of 6.8-9.0 Nm (60-80 lb-in).
Note: Do not turn connector body, turn clamp nut.

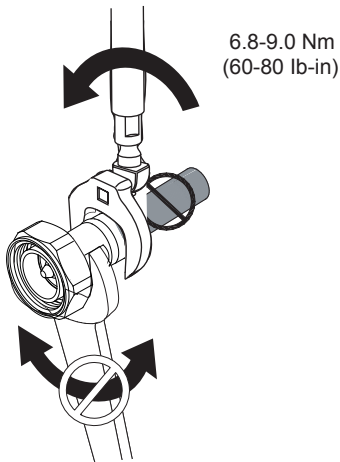

11. Coupling torque.

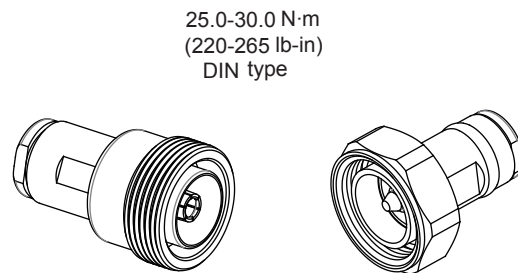

	表一 有毒有害物质或元素名称及含量标识格式					
	有毒有害物质或元素					
部件名称 (Part Name)	铅 (Pb)	汞 (Hg)	镉 (Cd)	六价铬 (Cr6+)	多溴联苯 (PBB)	多溴二苯醚 (PBDE)
连接器 (Connector)	X	O	O	O	O	O
O: 表示有毒有害物质在该部件所有的均质材料中的含量均在SJ/T 11363-2006规定的限量要求以下。 X: 表示该有毒有害物质至少在该部件的某一均质材料中的含量超出SJ/T 11363-2006规定的限量要求。						

Andrew LLC

Customer Service 24 hours
 U.S.A., Canada, Mexico: +1-800-255-1479
 U.K.: 0800 250055 Brazil: +55-15-2102-4000
 Other Europe: +44 592 782 612

www.commscope.com
 Visit our Web site at www.commscope.com or contact your local Andrew LLC representative for more information.
 © 2013 CommScope, Inc. All rights reserved.
 Andrew LLC is a trademark of CommScope. All trademarks identified by ® or ™ are registered trademarks or trademarks, respectively, of CommScope. This document is for planning purposes only and is not intended to modify or supplement any specifications or warranties relating to Andrew LLC products or services.

Notice: Andrew LLC disclaims any liability or responsibility for the results of improper or unsafe installation, inspection, maintenance, or removal practices.
 Aviso: Andrews LLC no acepta ninguna obligación ni responsabilidad como resultado de prácticas incorrectas o peligrosas de instalación, inspección, mantenimiento o retiro.
 Avis: Andrew LLC décline toute responsabilité pour les conséquences de procédures d'installation, d'inspection, d'entretien ou de retrait incorrectes ou dangereuses.
 Hinweis: Andrew LLC lehnt jede Haftung oder Verantwortung für Schäden ab, die aufgrund unsachgemäßer Installation, Überprüfung, Wartung oder Demontage auftreten.
 Atenção: A Andrew LLC abdica do direito de toda responsabilidade pelos resultados de práticas inadequadas e sem segurança de instalação, inspeção, manutenção ou remoção.
 Avvertenza: Andrew LLC declina eventuali responsabilità derivanti dall'esecuzione di procedure di installazione, ispezione, manutenzione e smontaggio improprie o poco sicure.
 注意: Andrew 公司申明對於不恰當或不安全的安裝、檢驗、維修或拆卸操作所導致的後果不負任何義務和責任

