

Installation Instructions

Connector Attachment

For Braided Cable CNT-300
BNC Male, Solder Pin, Crimp-type Body

Andrew Institute offers installation training.

Connector: 300PBM-CR

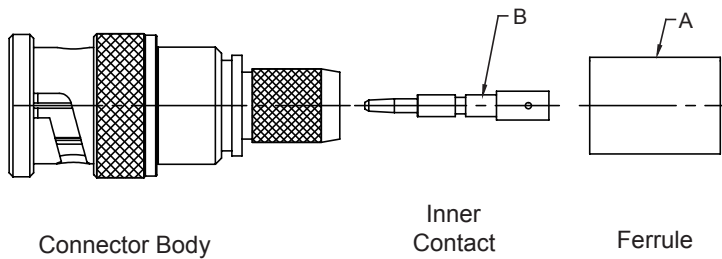

Tools

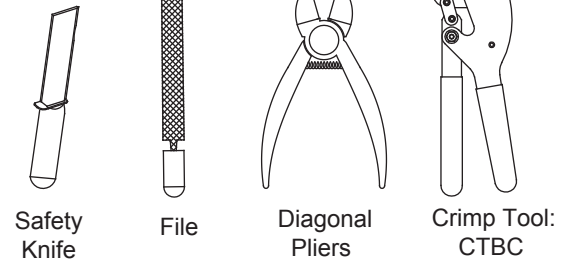

- 1.** Straighten first 200.0 mm (7.874") min. of the cable.

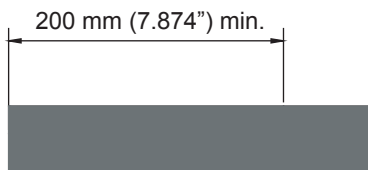

- 2.** Remove 17.0 mm (0.669") of Jacket only.

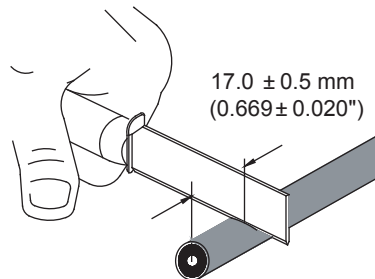

- 3.** Trim 6.5 mm (0.256") of Braid, exposing outer conductor.

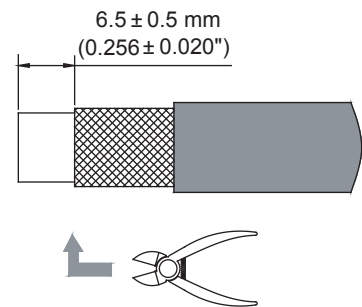

- 4.** Remove 5.0 mm (0.197") of foil & foam, exposing center conductor.

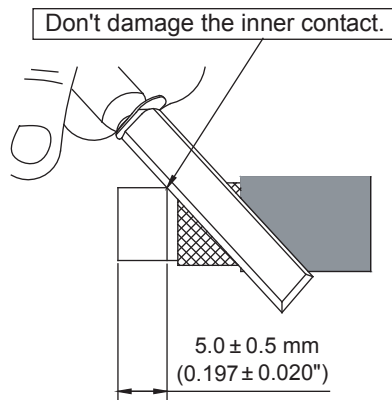

- 5.** Chamfer the center conductor at a 45° angle.

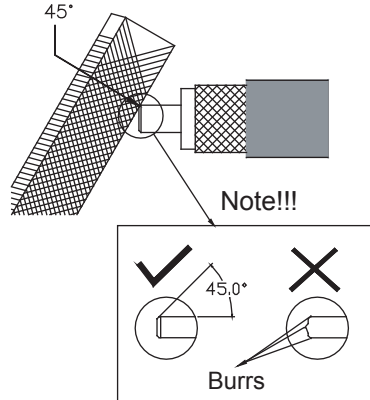

- 6.** Push part B onto the cable center conductor.

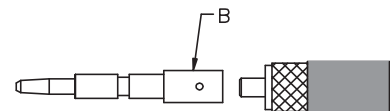

- 7.** Solder part B and cable center conductor together. Inspect soldering point, solder should fill cup but not spill over.

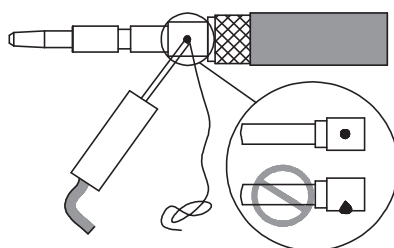

- 8.** Slide part A onto cable, splay out braid as shown.

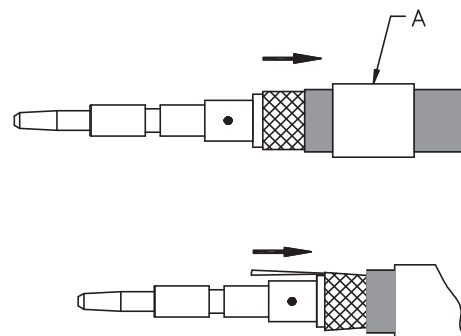

9. The cable attachment must be straight and aligned with the hole of connector insulator. Insert the cable attachment into connector body until stopped; the center conductor must be inserted into the insulator hole. Make sure the braid covers the body sleeve; then push part A onto braid.

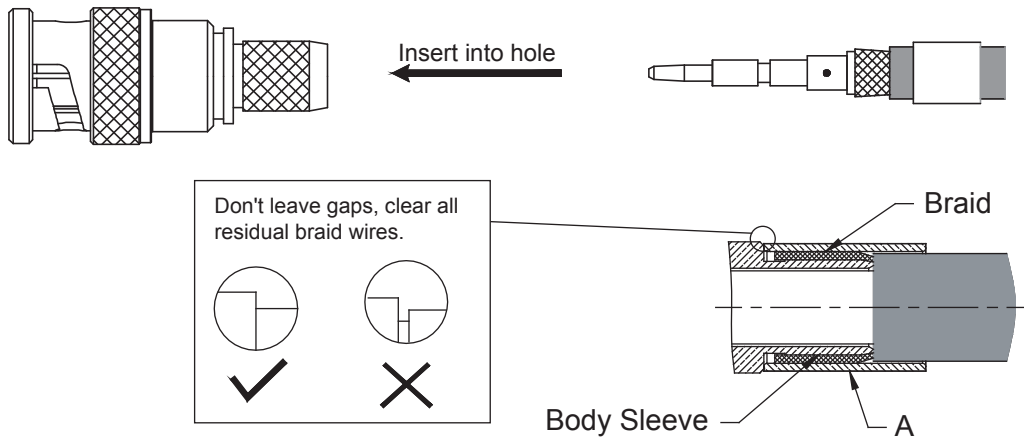

10. Crimp the ferrule at the area as shown. Crimp tool part number is: CTBC

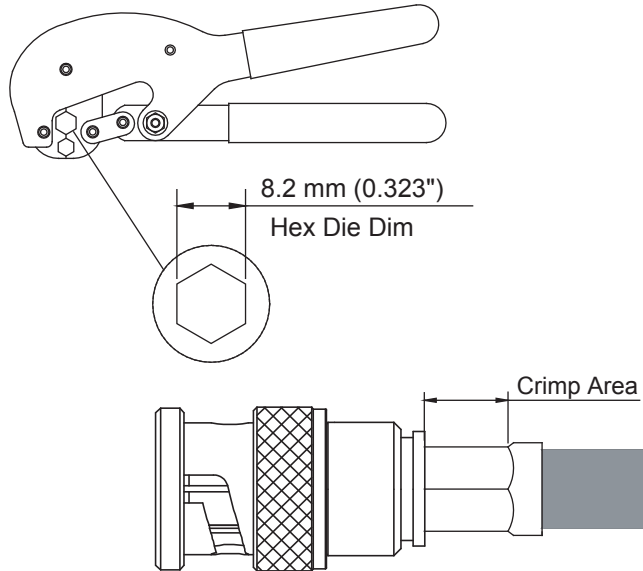

	表一 有毒有害物质或元素名称及含量标识格式					
	有毒有害物质或元素					
部件名称 (Part Name)	铅 (Pb)	汞 (Hg)	镉 (Cd)	六价铬 (Cr6+)	多溴联苯 (PBB)	多溴二苯醚 (PBDE)
连接器 (Connector)	X	O	O	O	O	O
O: 表示有毒有害物质在该部件所有的均质材料中的含量均在SJ/T 11363-2006规定的限量要求以下。 X: 表示该有毒有害物质至少在该部件的某一均质材料中的含量超出SJ/T 11363-2006规定的限量要求。						

Andrew LLC

Customer Service 24 hours

U.S.A., Canada, Mexico: +1-800-255-1479

U.K.: 0800 250055 Brazil: +55-15-2102-4000

Other Europe: +44 592 782 612

www.commscope.com

Visit our Web site at www.commscope.com or contact your local Andrew LLC representative for more information.

© 2015 CommScope, Inc. All rights reserved.

Andrew LLC is a trademark of CommScope. All trademarks identified by ® or ™ are registered trademarks or trademarks, respectively, of CommScope. This document is for planning purposes only and is not intended to modify or supplement any specifications or warranties relating to Andrew LLC products or services.

Notice: Andrew LLC disclaims any liability or responsibility for the results of improper or unsafe installation, inspection, maintenance, or removal practices.

Aviso: Andrews LLC no acepta ninguna obligación ni responsabilidad como resultado de prácticas incorrectas o peligrosas de instalación, inspección, mantenimiento o retiro.

Avis: Andrew LLC décline toute responsabilité pour les conséquences de procédures d'installation, d'inspection, d'entretien ou de retrait incorrectes ou dangereuses.

Hinweis: Andrew LLC lehnt jede Haftung oder Verantwortung für Schäden ab, die aufgrund unsachgemäßer Installation, Überprüfung, Wartung oder Demontage auftreten.

Atenção: A Andrew LLC abdica do direito de toda responsabilidade pelos resultados de práticas inadequadas e sem segurança de instalação, inspeção, manutenção ou remoção.

Avvertenza: Andrew LLC declina eventuali responsabilità derivanti dall'esecuzione di procedure di installazione, ispezione, manutenzione e smontaggio improprie o poco sicure.

注意: Andrew 公司申明對於不恰當或不安全的安裝、檢驗、維修或拆卸操作所導致的後果不負責任 何義務和責任

