

- 1.0 GENERAL NOTES  
 1.1 ALL METRIC DIMENSIONS ARE IN BRACKETS [X.X]  
 1.2 FOR PATENT INFO: <https://www.cs-pat.com>  
 2.0 DESIGN NOTES  
 3.0 MANUFACTURING/SPECIAL REQUIREMENTS  
 3.1 TIGHTEN ALL BOLTS SECURING FLAT PLATES BY THE TURN-OF-NUT METHOD. TIGHTEN ALL U-BOLTS USING TURN-OF-NUT METHOD WITH ATTENTION TO LEAVE EQUAL DISTANCE AND EQUAL FORCE ON EACH LEG OF THE U-BOLT.  
 4.0 TEST  
 5.0 PACKAGING  
 5.1 PACKAGING SHALL MEET COMMSCOPE REQUIREMENTS PER DOCUMENT IS-PL-3005  
 5.2 PRINTED DOCUMENT TO BE PLACED INSIDE POLYBAG AND THEN IN SHIPPING CONTAINER  
 5.3 EXTRA HARDWARE MAY BE SUPPLIED, BAGGED AND SHIPPED

REVISIONS			
REV.	DESCRIPTION	DATE	APPROVED
A	INITIAL RELEASE	JL1183 16MAR23	JAHAINES 40168212CMO
B	UPDATED DRAWING FORMAT; PL625-72512 WAS PLK8-F1-2	LL1090 14MAY24	BA1025 40195501CMO

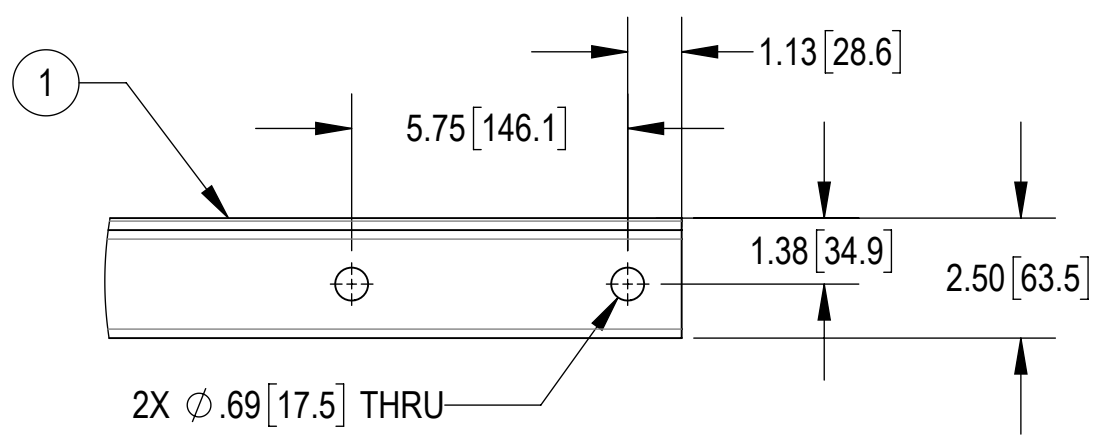

DETAIL C  
SCALE 1:4

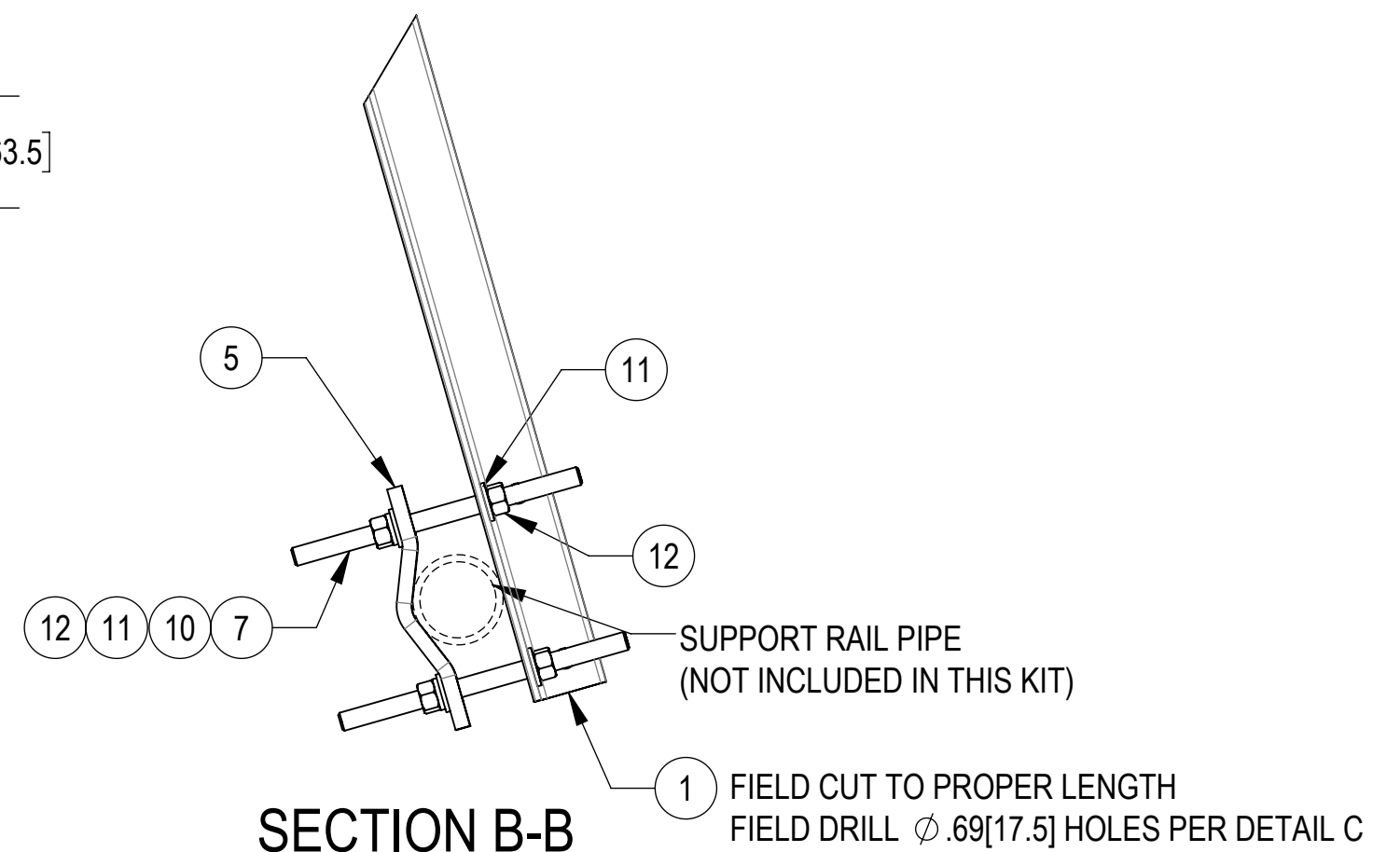

SECTION B-B  
SCALE 1:6

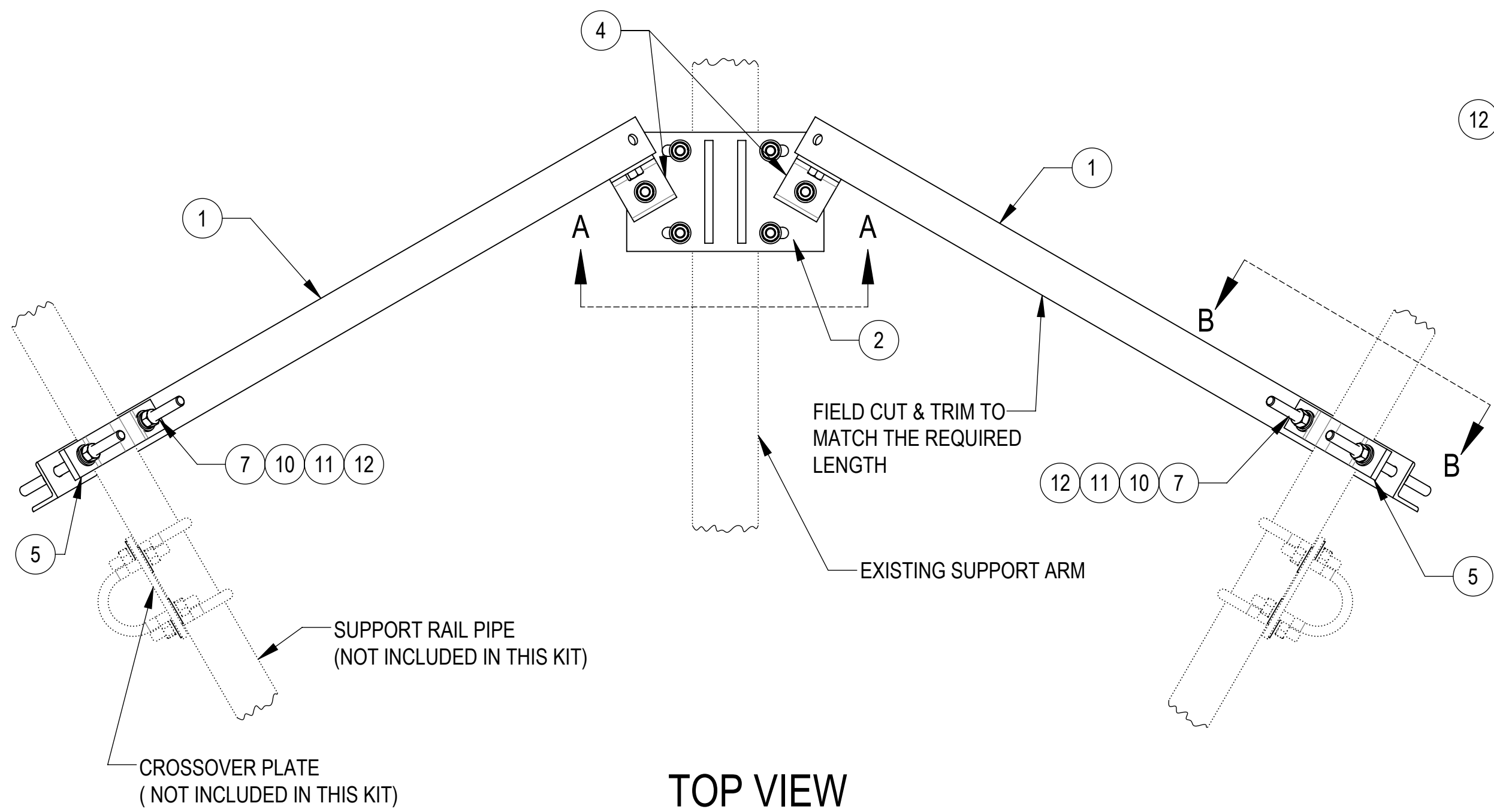

TOP VIEW

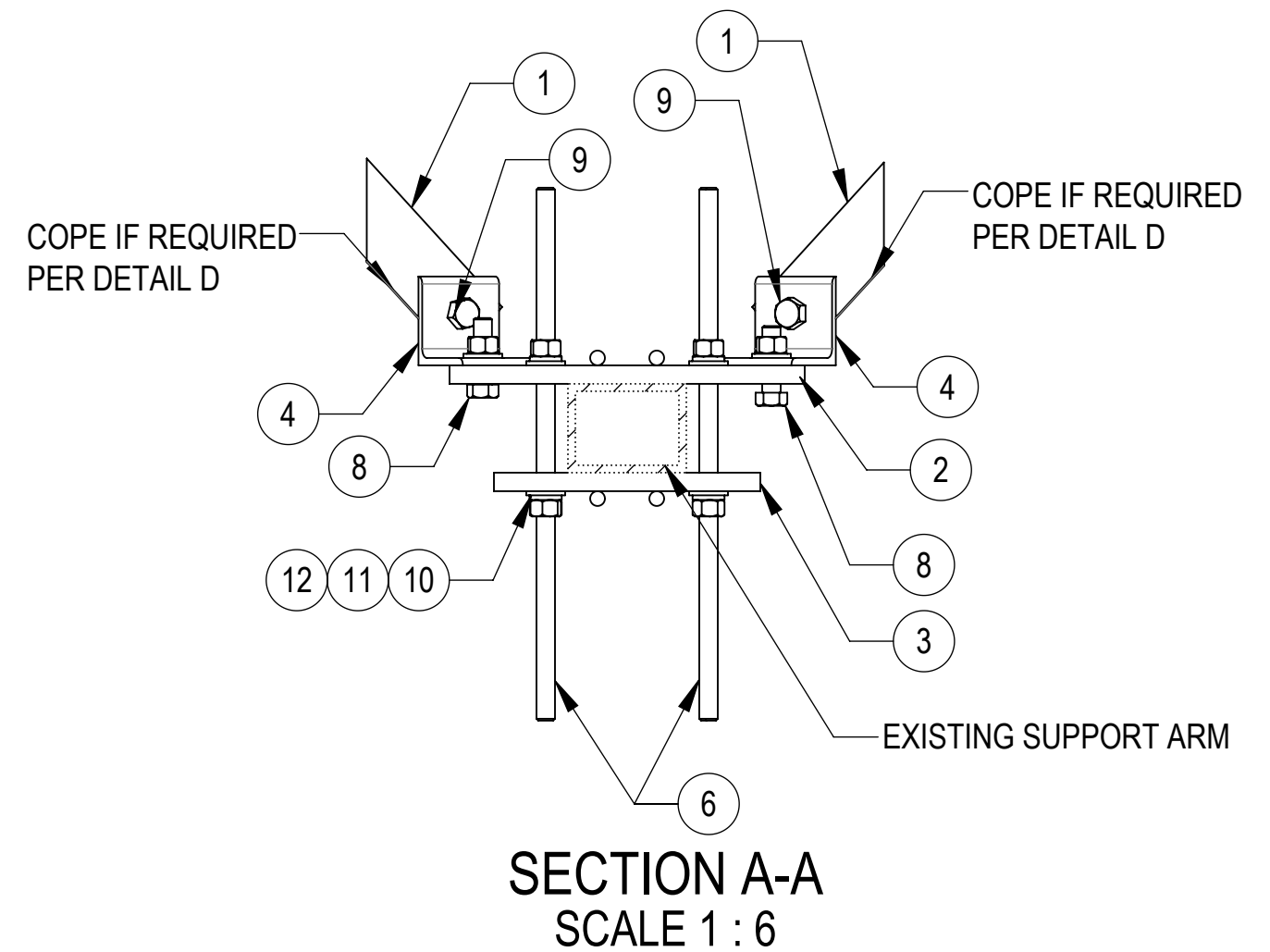

SECTION A-A  
SCALE 1:6

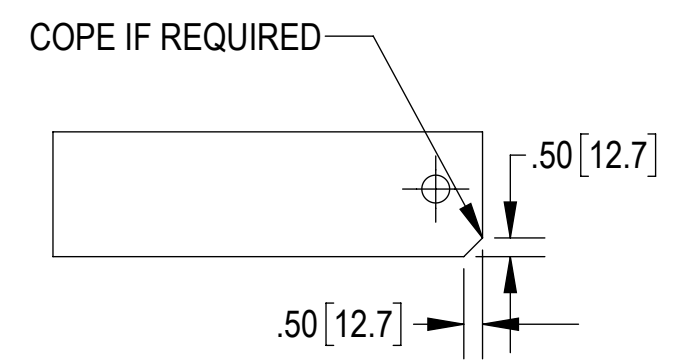

FRONT VIEW  
DETAIL D

COMPONENT PART NUMBERS PROVIDED FOR ASSEMBLY PURPOSES;  
 INDIVIDUAL COMPONENTS MAY BE SHIPPED AS PARTS WITHIN AN INCLUDED KIT.

ITEM	PART NO.	DESCRIPTION	QTY.	WEIGHT	NOTE
1	A-SFK3-01	ANGLE 2-1/2" X 2-1/2" X 1/4"	2	19.11 LBS	
2	PL625-72512	WELDMENT, TOP MOUNTING PLATE	1	15.42 LBS	
3	PLK8-F2-3	WELDMENT, BOTTOM MOUNTING PLATE	1	11.63 LBS	
4	AL-333	BRACKET, V-BRACING CLIP	2	1.17 LBS	
5	VCP	CLAMP, MOUNTING	2	0.28 LBS	
6	MT-382-18	5/8" X 18" GALV THREADED ROD	4	1.55 LBS	
7	MT-381-10	5/8" X 10" GALV THREADED ROD	4	0.86 LBS	
8	GB-0522A	5/8" X 2-1/4" GALV BOLT KIT (A325)	2	0.28 LBS	INCLUDES BOLT, LOCK WASHER AND NUT
9	GB-0516A	5/8" X 1-3/4" GALV BOLT KIT A325	2	0.24 LBS	INCLUDES BOLT, LOCK WASHER AND NUT
10	GWF05A	GALV FLAT WASHER HARDENED 5/8", 1.30D	20	0.04 LBS	
11	GWL-05	5/8" GALV LOCK WASHER	16	0.03 LBS	
12	GN-05	5/8" GALV HEX NUT	16	0.08 LBS	

DENSITY	47.77	lbs/in <sup>3</sup>
MASS	47.77	lbs
VOLUME	303.69	in <sup>3</sup>
SURFACE AREA	2116.32	in <sup>2</sup>
HEIGHT	(12.0")	
LENGTH	(78.0")	
WIDTH	(10.0")	

© 2024 CommScope, Inc. Confidential

**COMMSCOPE, INC. OF NORTH CAROLINA**

TOLERANCES  
 1 PLACE .X[X] ± 0.1[3.0]    3 PLACE .XXX[X] ± 0.03[0.8]  
 2 PLACE .XX[X] ± 0.06[1.5]    ANGLES ± 1°

SAP MATERIAL MASTER  
**MUK-PLK8**

FINISH: \_\_\_\_\_ MATERIAL: \_\_\_\_\_

NAME	DATE	TITLE
CE JL1183	16MAR23	SUPPORT RAIL BRACING KIT
RW LL1090	05/28/2024	
AD YMENG	05/28/2024	
RE YMENG	05/28/2024	

SCALE: **1:6** DOCUMENT NO.: **MUK-PLK8**

SIZE	Auth Group	INSL	MODEL	DRAWING			SHEET		
<b>C</b>			VERSION	STATUS	REVISION	VERSION	STATUS	REVISION	1 OF 1
			07	RE	A	01	RE	B	