

| REVISIONS | | | |
|-----------|---|-------------|----------|
| REV. | DESCRIPTION | DATE | APPROVED |
| A | ECR 8000027646: REL TO PRODUCTION PER EAO 604184. | 05JAN18 YYW | DG/NH |

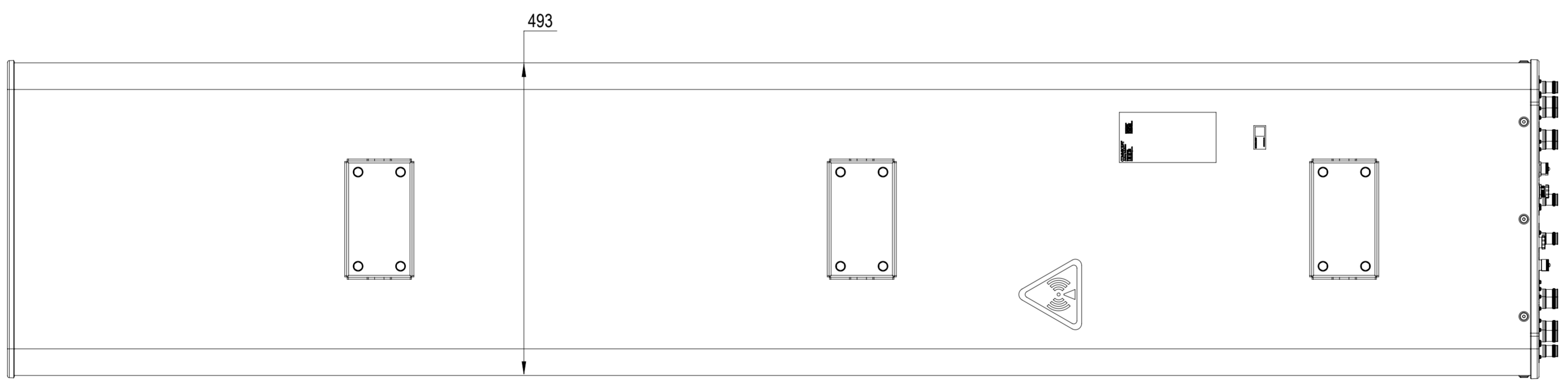
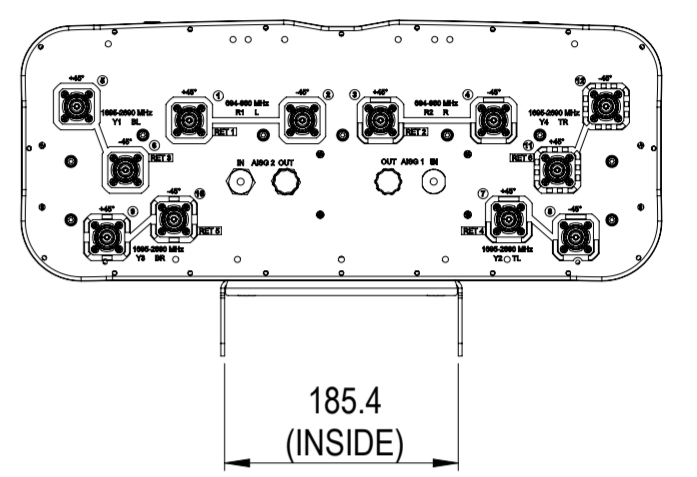
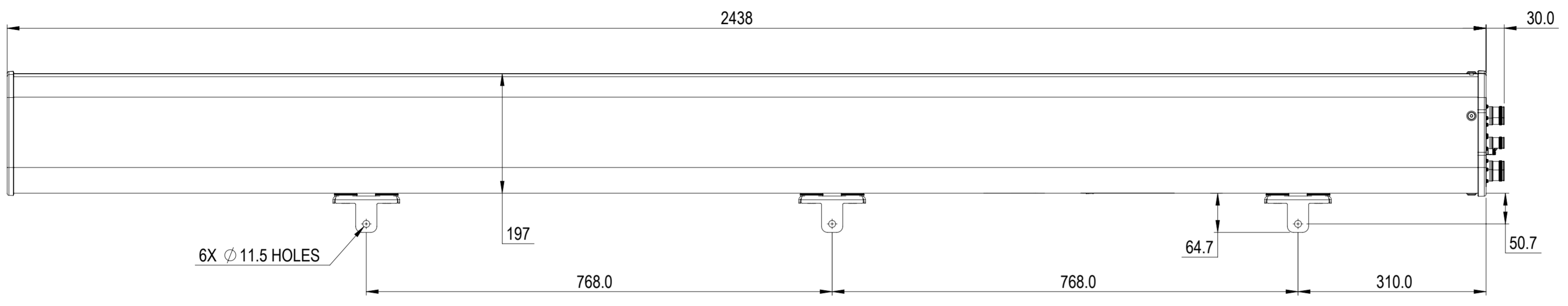

RRV4-65C-R6

COMMSCOPE, INC. OF NORTH CAROLINA

| TOLERANCES | | SAP MATERIAL MASTER | | | | | | | | | | | | | | | |
|--|---------------|--|-----------------------------------|------|------|-------|-----------|------------|------------------------|-----------|------------|-----------|------------|-----------|------------|------------|------------|
| 0 PLACE X ± | 2 PLACE .XX ± | | | | | | | | | | | | | | | | |
| 1 PLACE .X ± | ANGLES ± | | | | | | | | | | | | | | | | |
| FINISH | | MATERIAL | | | | | | | | | | | | | | | |
| UNLESS OTHERWISE SPECIFIED DIMENSIONS ARE IN MILLIMETERS INTERPRET PER ISO STANDARDS HANDBOOK 1 TECHNICAL DRAWINGS VOLUMES 1 & 2, THIRD EDITION (2002) | | <table border="1"> <thead> <tr> <th>NAME</th> <th>DATE</th> <th>TITLE</th> </tr> </thead> <tbody> <tr> <td>CE YY1025</td> <td>01/05/2017</td> <td rowspan="5" style="text-align: center; vertical-align: middle;">PRODUCT DRAWING</td> </tr> <tr> <td>RW MC1105</td> <td>03/01/2018</td> </tr> <tr> <td>RV MA1053</td> <td>03/05/2018</td> </tr> <tr> <td>AD ZH1011</td> <td>03/06/2018</td> </tr> <tr> <td>RE ZHHCHEN</td> <td>03/06/2018</td> </tr> </tbody> </table> | | NAME | DATE | TITLE | CE YY1025 | 01/05/2017 | PRODUCT DRAWING | RW MC1105 | 03/01/2018 | RV MA1053 | 03/05/2018 | AD ZH1011 | 03/06/2018 | RE ZHHCHEN | 03/06/2018 |
| NAME | DATE | TITLE | | | | | | | | | | | | | | | |
| CE YY1025 | 01/05/2017 | PRODUCT DRAWING | | | | | | | | | | | | | | | |
| RW MC1105 | 03/01/2018 | | | | | | | | | | | | | | | | |
| RV MA1053 | 03/05/2018 | | | | | | | | | | | | | | | | |
| AD ZH1011 | 03/06/2018 | | | | | | | | | | | | | | | | |
| RE ZHHCHEN | 03/06/2018 | | | | | | | | | | | | | | | | |
| ECN 8000027646-O | | SCALE 1:6 | DOCUMENT NO. RRV4-65C-R6-L | | | | | | | | | | | | | | |
| SIZE A2 | | WORK AREA 23 | MODEL | | | | | | | | | | | | | | |
| DENSITY g/mm ³ | | DRAWING | | | | | | | | | | | | | | | |
| MASS grams | | VERSION 00 | STATUS RE | | | | | | | | | | | | | | |
| VOLUME mm ³ | | REVISION A | VERSION 00 | | | | | | | | | | | | | | |
| SURFACE AREA mm ² | | REVISION A | STATUS RE | | | | | | | | | | | | | | |
| HEIGHT | | REVISION A | REVISION A | | | | | | | | | | | | | | |
| LENGTH | | SHEET | | | | | | | | | | | | | | | |
| WIDTH | | 1 OF 1 | | | | | | | | | | | | | | | |