

REVISIONS			
REV	CMO	DATE	APPROVED
C	40104596CMO	04-OCT-2019	ODVL
D	40105823CMO	13-FEB-2020	ODVL

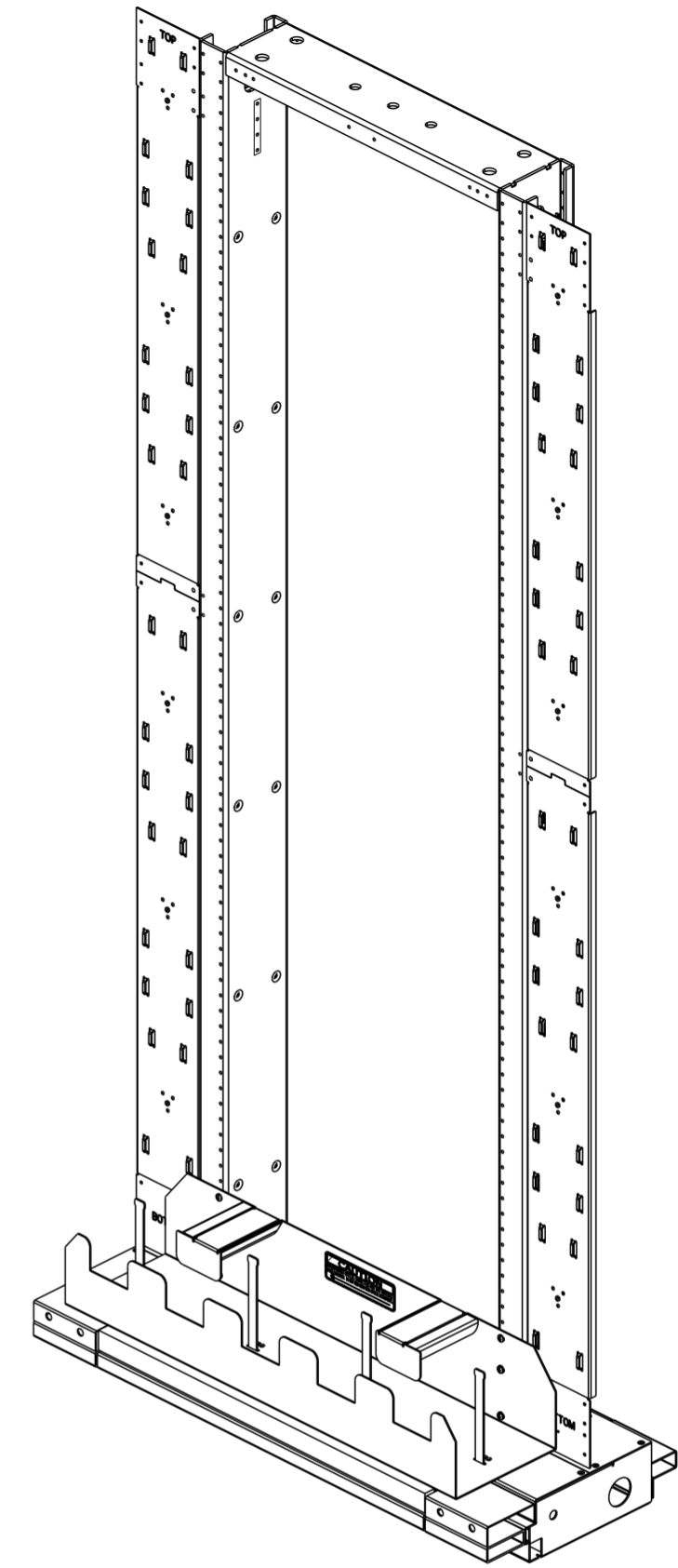
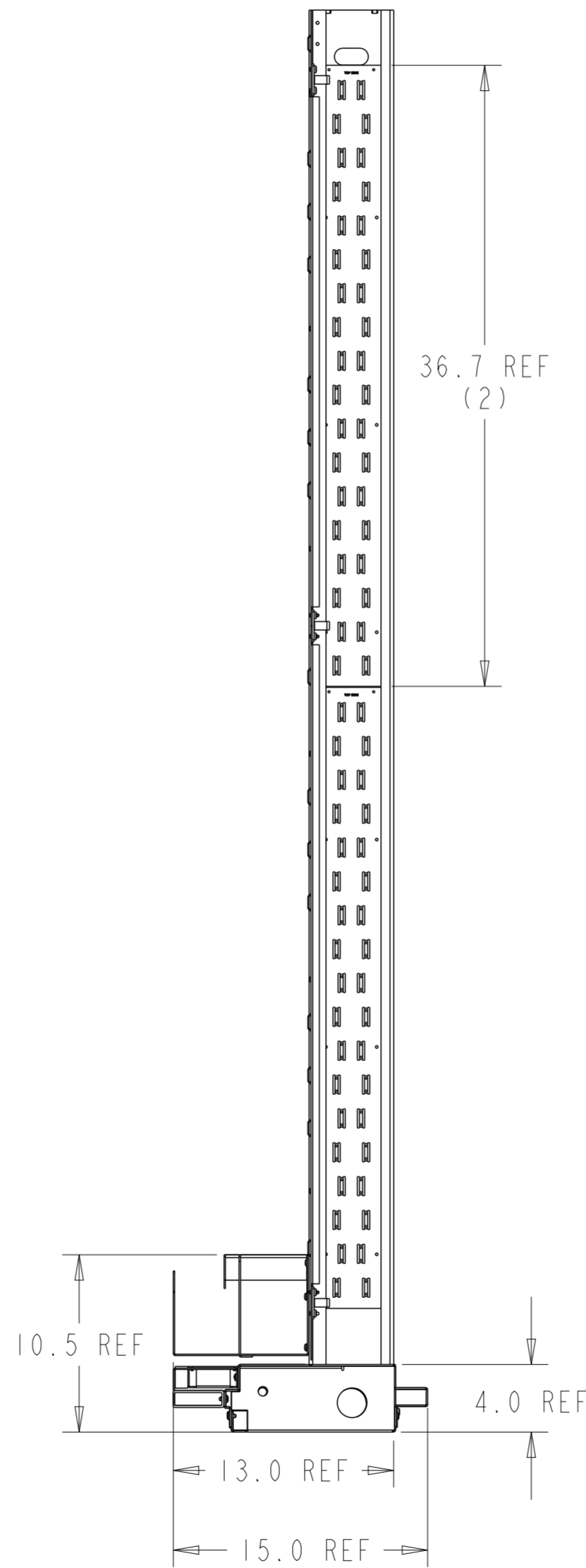
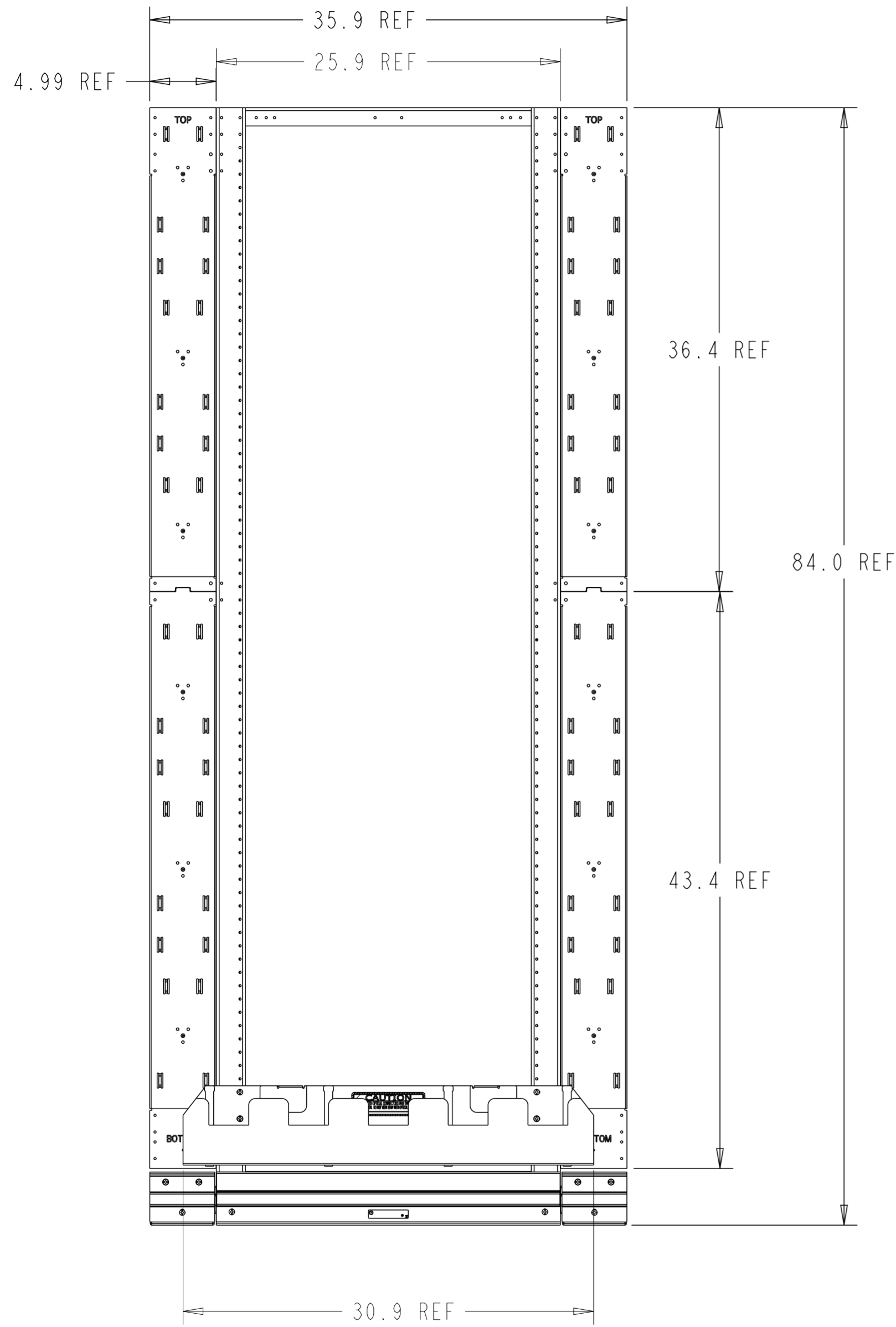

NOTES:

- [1] DIMENSION FROM BOTTOM OF PANEL TO CENTER OF FIRST SPOOL SPACE.
- 2. SEE SHEET THREE FOR PARTS LISTS. DESIGNATED SCREWS AND HARDWARE BAGGED AND PLACED INSIDE FILLER GUARD BOX.
- [3] SEE DETAIL A (SHEET 3) FOR IMP MOUNTING DETAIL. INSTALL IMP SECTIONS AS FOLLOWS: INSTALL BOTTOM SECTION FIRST (NOTE "BOTTOM" IS STAMPED ON THE LOWER END OF THE PANEL), THEN INSTALL TOP SECTION (NOTE "TOP" IS STAMPED ON UPPER END OF PANEL).
- [4] REF IMP SECTION MARKING: "BOTTOM" & "TOP".
- 5. SEE CROSS/INTERCONNECT PROCEDURES GUIDE (ADCP-90-140) FOR JUMPER ROUTING INSTRUCTIONS.
- [6] REAR COVER IS REMOVABLE FOR UNDERFLOOR ACCESS.

FDF-FIPSKELBAY-ATT
CATALOG No.

COMMSCOPE, INC.			
DRAFTER OSCAR VALENZUELA		TITLE FDF-FIPSKELBAY-ATT: SKEL RACK INST DWG	
ENGINEER LUIS L. BALANDRAN	SIZE A2	SCALE 1.000	DOCUMENT NO. 660003235
CUSTOMER DRAWING			REVISION D
			SHEET 1 OF 3

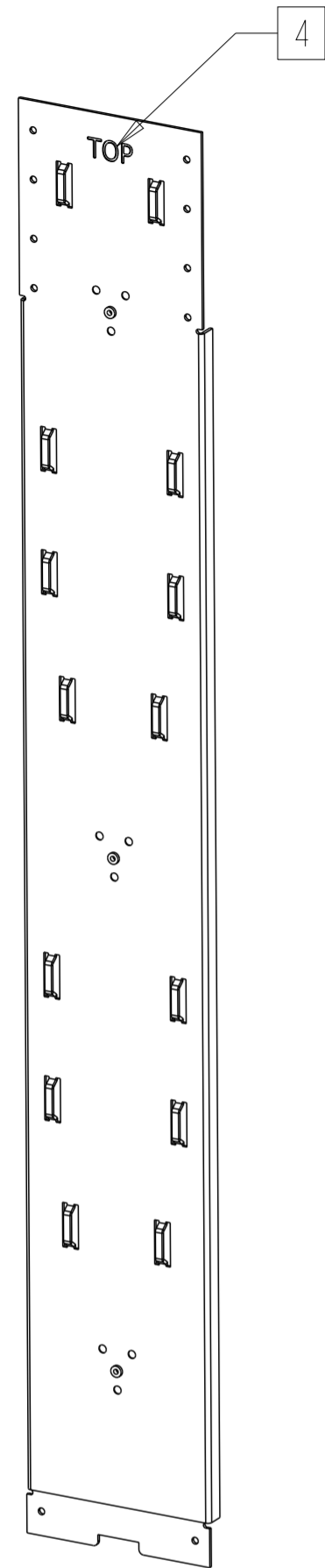

FIG. 2
TOP

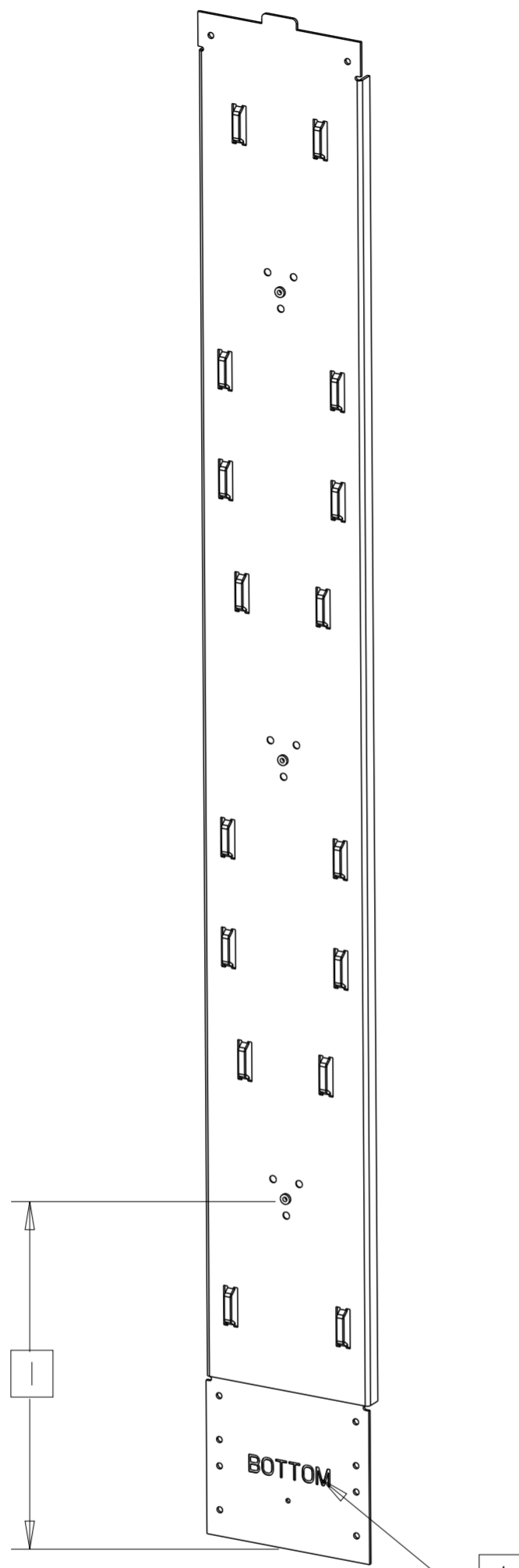

FIG. 1
BOTTOM

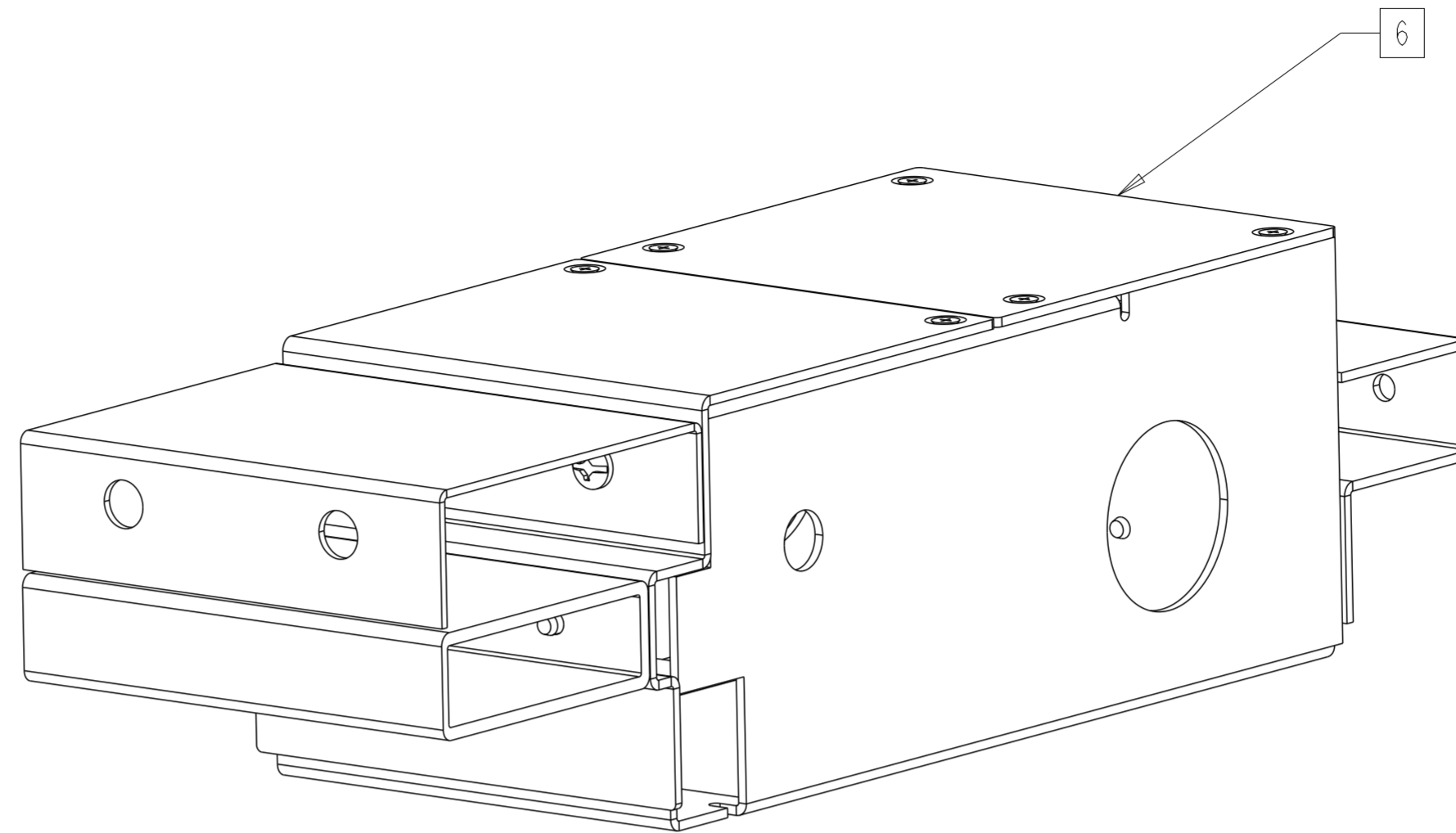
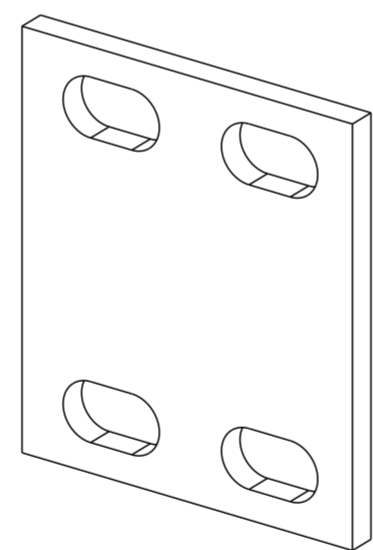
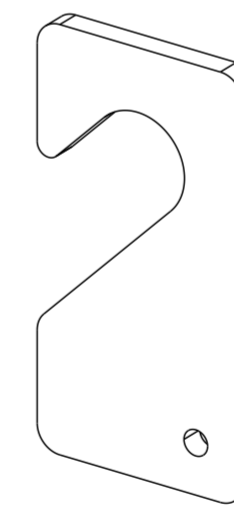

FIG. 3
FILLER GUARD BOX



JUNCTION PLATE



SPACER

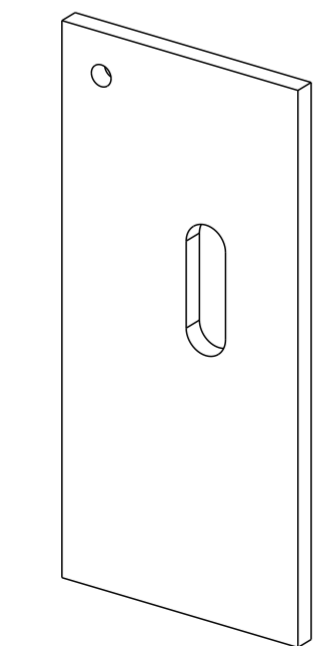

END GUARD
MOUNTING BRACKET

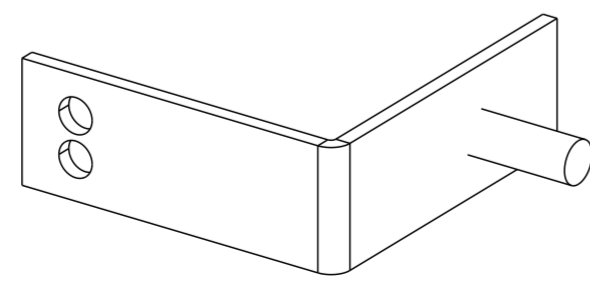

END GUARD
MOUNTING PLATE

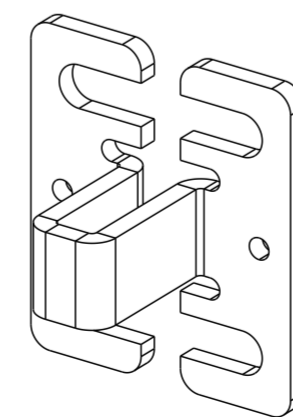

SEISMIC
JUNCTION PLATE

COMMSCOPE, INC.			
DRAFTER OSCAR VALENZUELA		TITLE FDF-FIPSKELBAY-ATT: SKEL RACK INST DWG	
ENGINEER LUIS L. BALANDRAN		SIZE A2	SCALE 0.125
		DOCUMENT NO. 660003235	
CUSTOMER DRAWING			REVISION D
			SHEET 2 OF 3

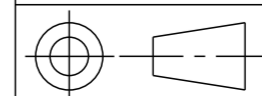

A
B
C
D
E
F
G
H

A
B
C
D
E
F
G
H

CAT #	RACK HEIGHT	DIM TO FIRST SPOOL SPACE 1	TOTAL NUMBER OF SPOOL SPACES	IMP SECTION		SEISMIC RACK JUNCTION PLATE QTY	JUNCTION PLATE QTY	SPACER QTY	FILLER GUARD BOX ASSY	12-24 SCREWS QTY	3/8-16 BOLT QTY	3/8 LOCK WASHER QTY	3/8-16 NUT QTY	1/4-20 NUT QTY	1/4 FLAT WASHER QTY	1/4 LOCK WASHER QTY	END GUARD MOUNTING PLATE QTY	END GUARD MOUNTING BRACKET QTY
				BOTTOM FIG 1 SPOOL SPACES QTY	TOP FIG 2 SPOOL SPACES QTY													
760243935	7'	9.987"	6	1/3	1/3	6	6	2	FIG 3	24	2	2	2	1	1	1	1	1

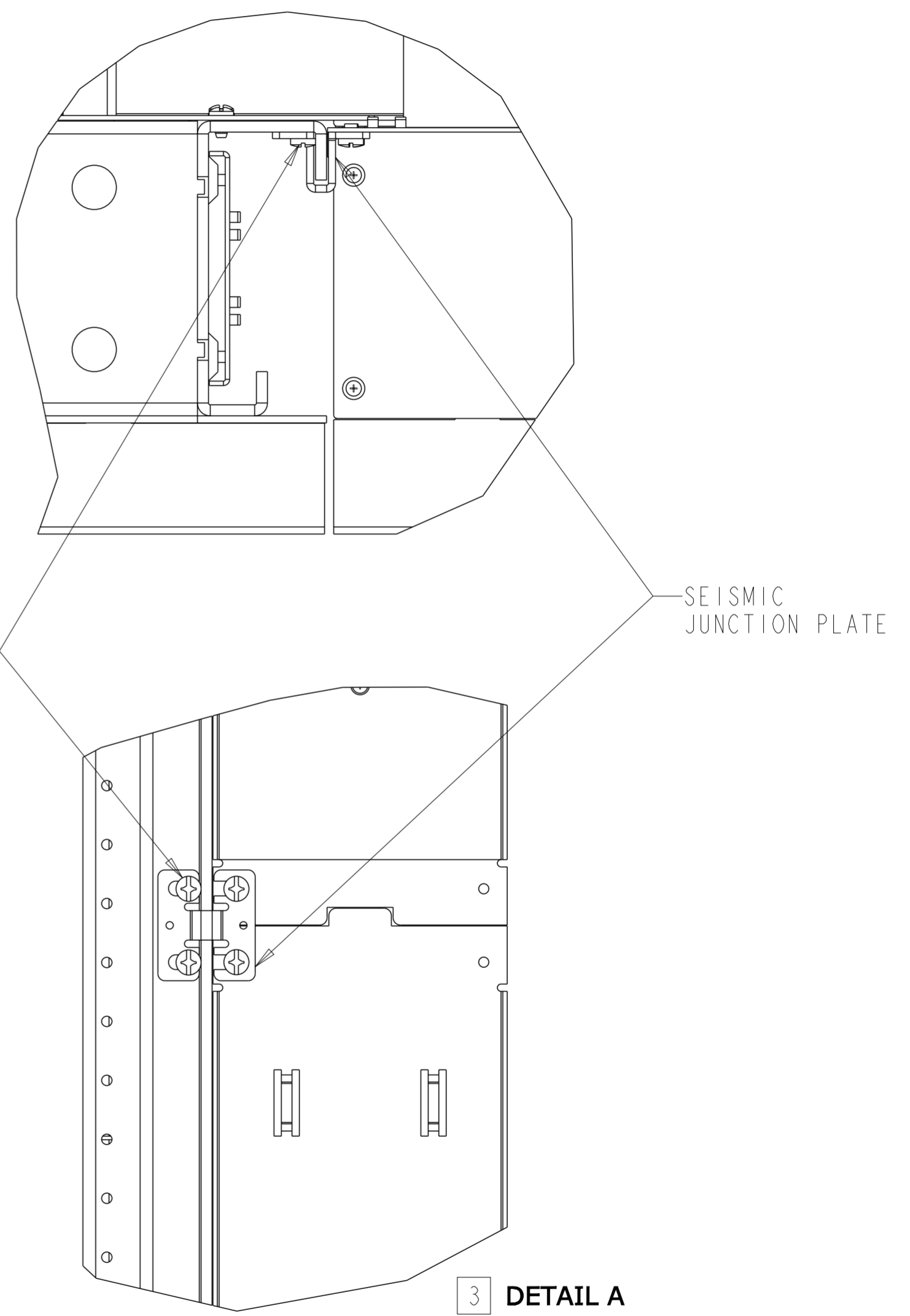
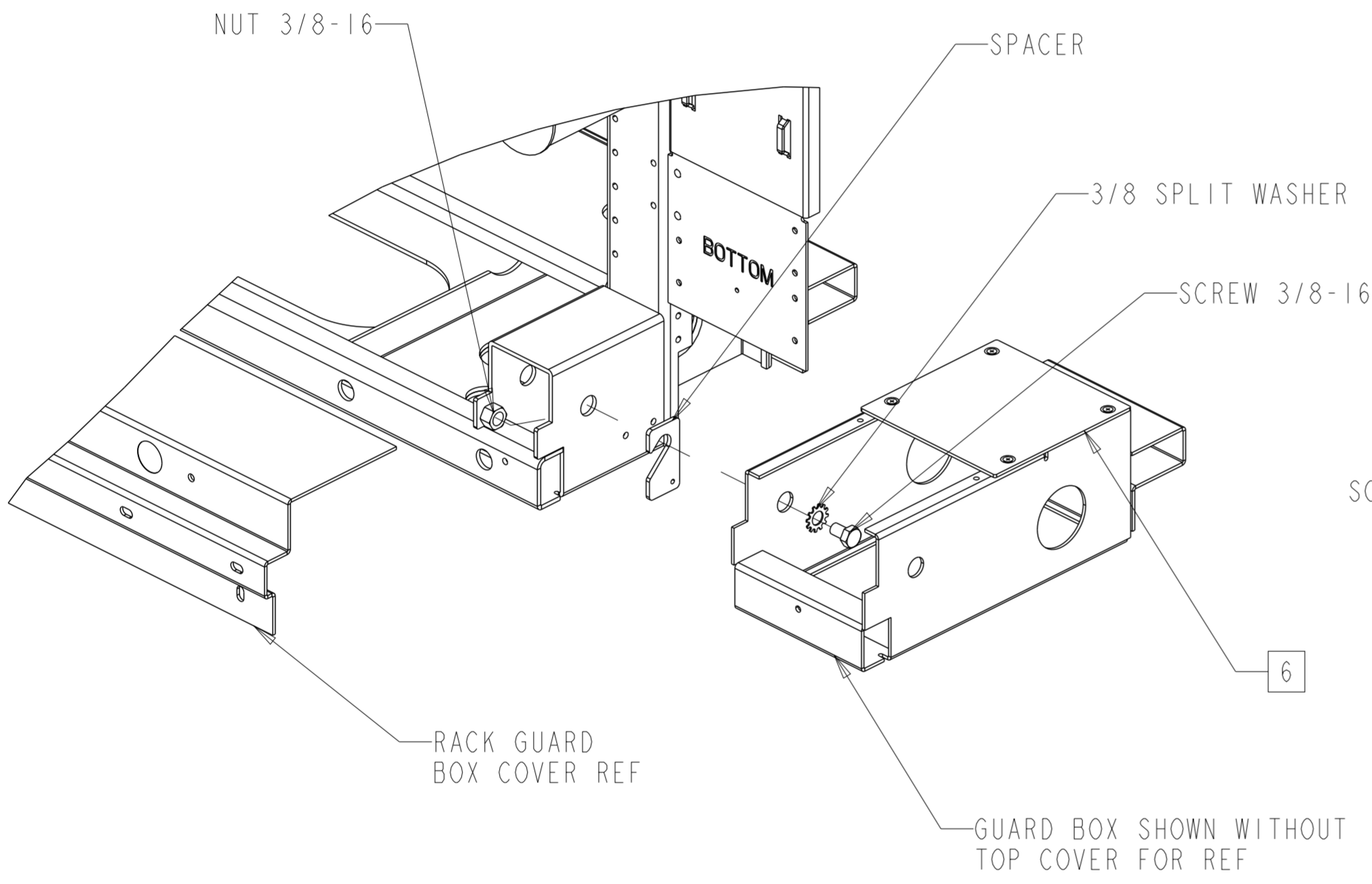

COMMSCOPE, INC.			
DRAFTER OSCAR VALENZUELA		TITLE FDF-FIPSKELBAY-ATT: SKEL RACK INST DWG	
ENGINEER LUIS L. BALANDRAN	SIZE A2	SCALE 0.300	DOCUMENT NO. 660003235
CUSTOMER DRAWING			REVISION D
			SHEET 3 OF 3