

REVISIONS			
REV	CMO	DATE	APPROVED
C	40104596CMO	20-JAN-2020	ODVL
D	40105823CMO	13-FEB-2020	ODVL

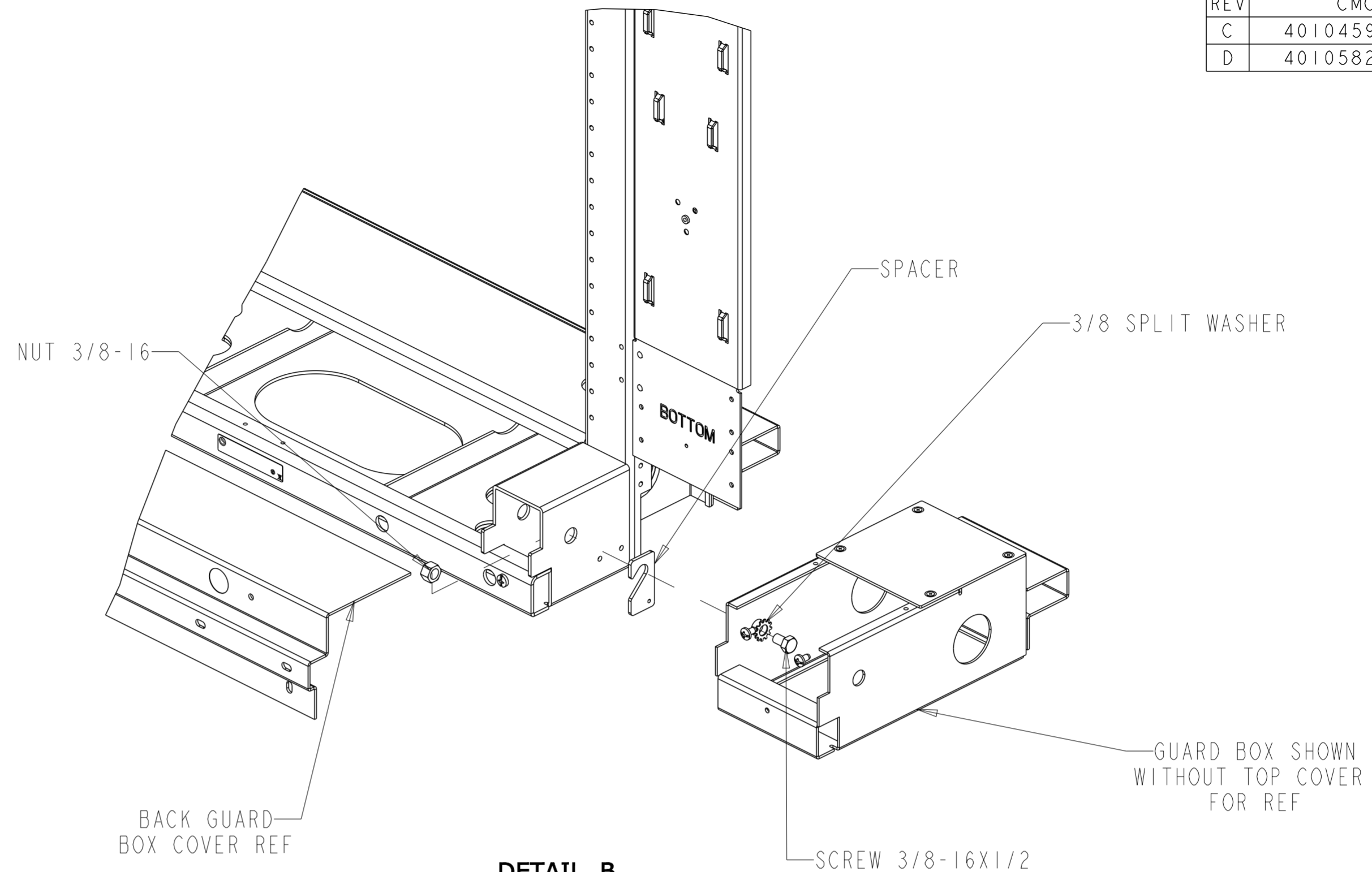
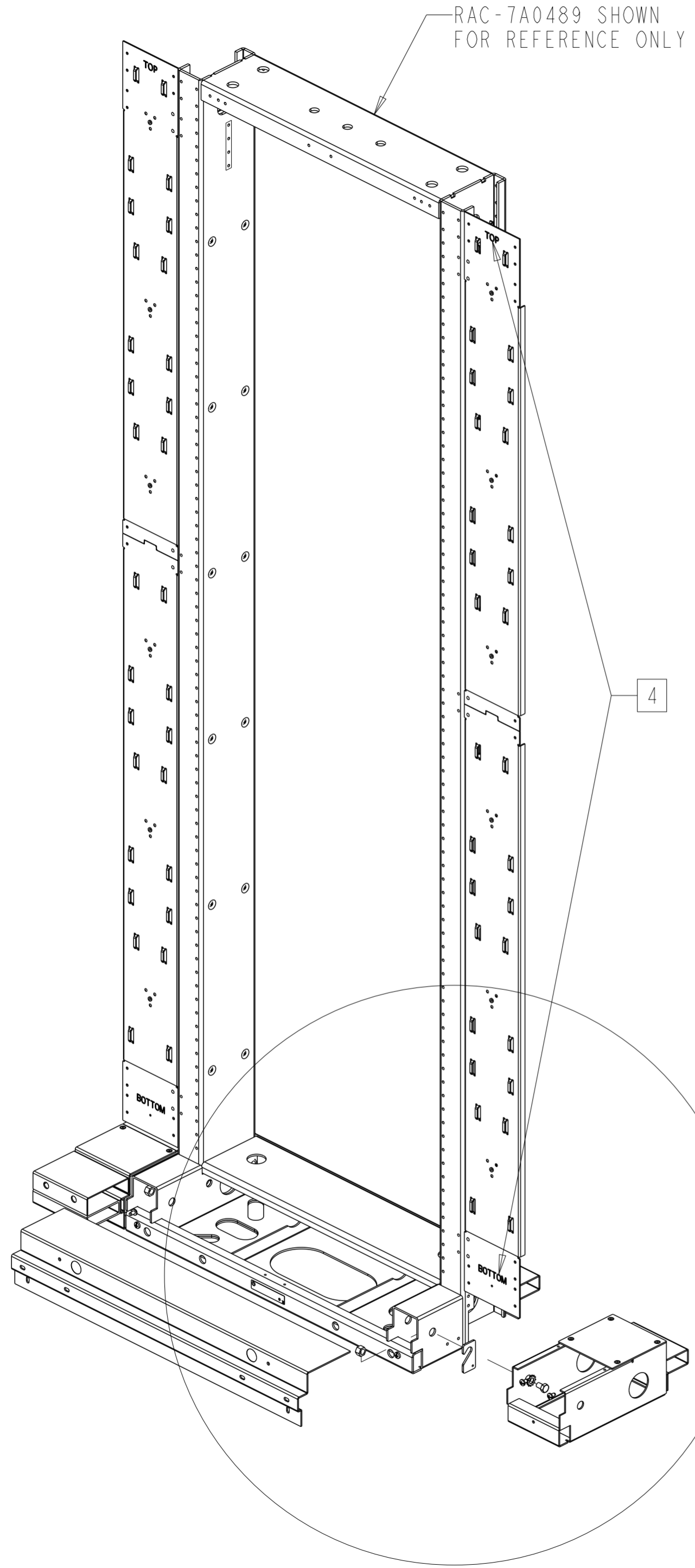

**DETAIL B**  
SCALE 0.280

**NOTES:**

- 1 DIMENSION FROM TOP OF GUARD BOX TO CENTER OF FIRST SPOOL SPACE.
- 2. SEE SHEET #2 FOR PARTS LISTS. DESIGNATED SCREWS AND HARDWARE ARE BAGGED AND PLACED INSIDE FILLER GUARD BOX ASSEMBLY FOR SHIPPING.
- 3 SEE DETAIL A (SHEET #2) FOR IMP MOUNTING DETAIL.  
INSTALL IMP SECTIONS AS FOLLOWS:  
INSTALL BOTTOM SECTION FIRST  
(NOTE "BOTTOM" IS STAMPED ON THE LOWER END OF THE PANEL), THEN  
INSTALL TOP SECTION (NOTE "TOP" IS STAMPED ON UPPER END OF PANEL).
- 4 REF IMP SECTION MARKING: "BOTTOM", "TOP".
- 5. SEE IMP INSTALLATION GUIDE (ADCP-90-137) FOR FILLER GUARD BOX AND IMP INSTALLATION INSTRUCTIONS.
- 6. SEE CROSS/INTERCONNECT PROCEDURES GUIDE (ADCP-90-140) FOR JUMPER ROUTING INSTRUCTIONS.

<b>COMMSCOPE, INC.</b>			
DRAFTER OSCAR VALENZUELA		TITLE VELCRO IMP GD & IMP INST DWG	
ENGINEER LUIS L. BALANDRAN	SIZE A2	SCALE 0.150	DOCUMENT NO. <b>660003234</b>
CUSTOMER DRAWING			REVISION D
			SHEET 1 OF 2

CAT #	RACK HEIGHT	IMP SECTION		SEISMIC RACK JUNCTION PLATE QTY	JUNCTION PLATE QTY	SPACER QTY	FILLER GUARD BOX ASSY	12-24 SCREWS QTY	3/8-16 BOLT QTY	3/8 LOCK WASHER QTY	3/8-16 NUT QTY	1/4-20 NUT QTY	1/4 FLAT WASHER QTY	1/4 LOCK WASHER QTY	END GUARD MOUNTING PLATE QTY	END GUARD MOUNTING BRACKET QTY
		BOTTOM QTY/SPOOL SPACES	TOP QTY/SPOOL SPACES													
<b>760243604</b>	7'	1/3	1/3	6	6	2	1	26	2	2	2	1	1	1	1	1

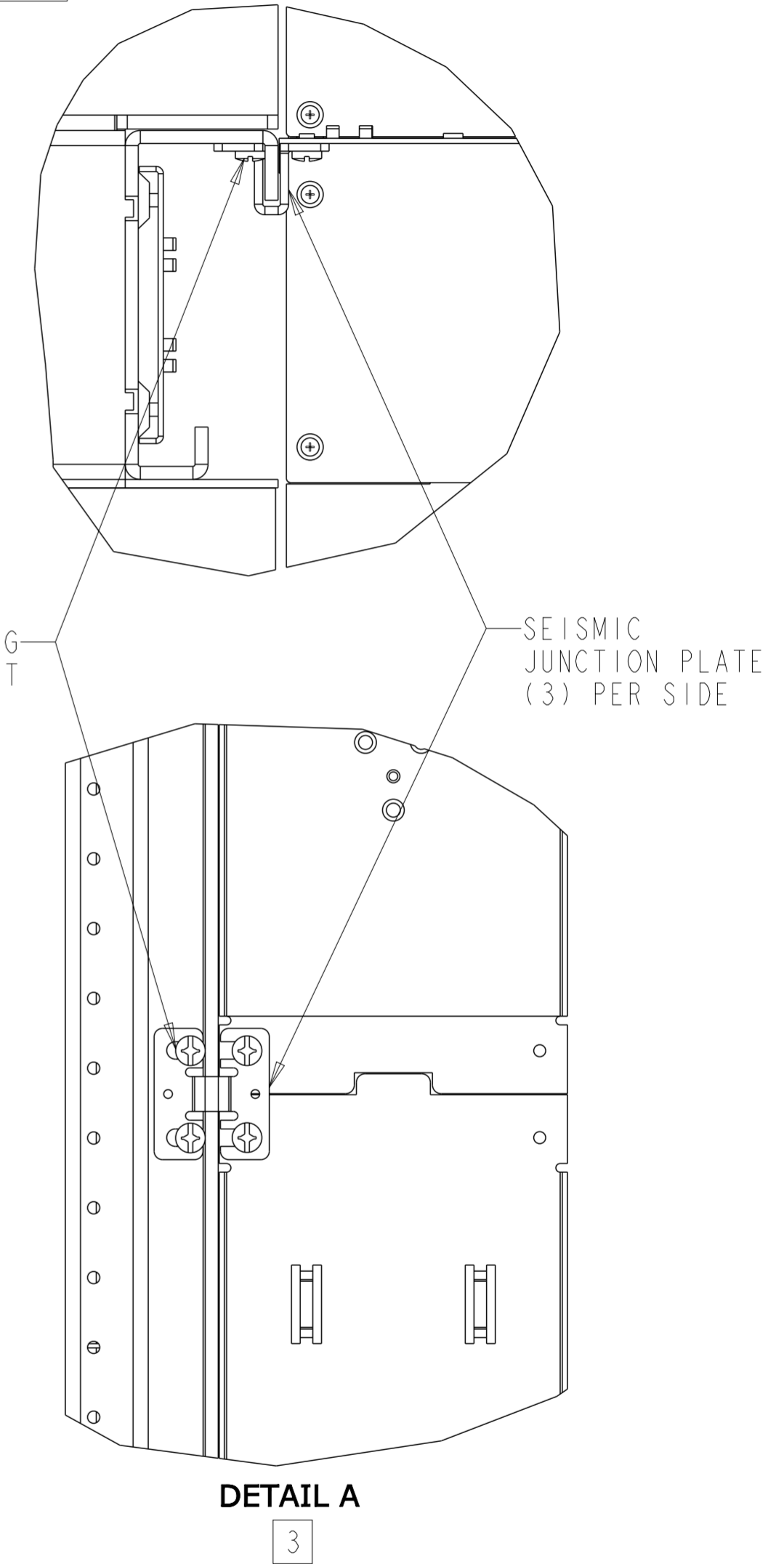
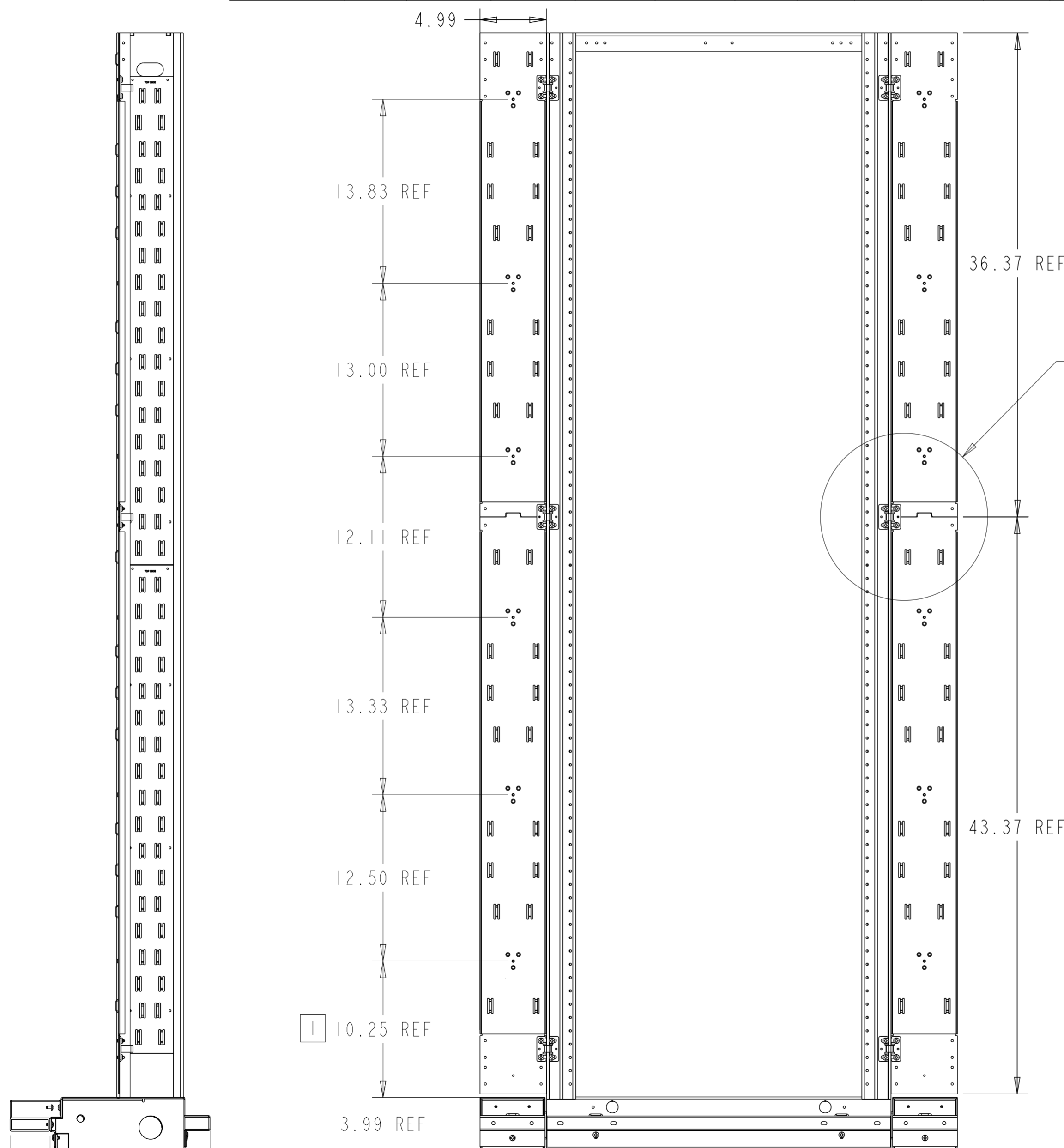

<b>COMMSCOPE, INC.</b>			
DRAFTER OSCAR VALENZUELA		TITLE VELCRO IMP GD & IMP INST DWG	
ENGINEER LUIS L. BALANDRAN		SIZE A2	SCALE 0.150
		DOCUMENT NO. <b>660003234</b>	
CUSTOMER DRAWING			REVISION D
			SHEET 2 OF 2