

4

3

2

1

NOTES:

- 1.0 GENERAL
 - 1.1 ALL METRIC DIMENSIONS ARE IN BRACKETS
 - 1.2 FOR PATENT INFO :<https://www.cs-pat.com>
- 2.0 DESIGN NOTES
- 3.0 MANUFACTURING/SPECIAL REQUIRMENTS
- 4.0 TEST
- 5.0 PACKAGING

REVISIONS				
REV.	ECN	DESCRIPTION	DATE	APPROVED
A		INITIAL RELEASE	11/20/09	MSM
B	8000042590	UPDATED SQUARE TUBE THICKNESS	9/1/2020	RKH

D

D

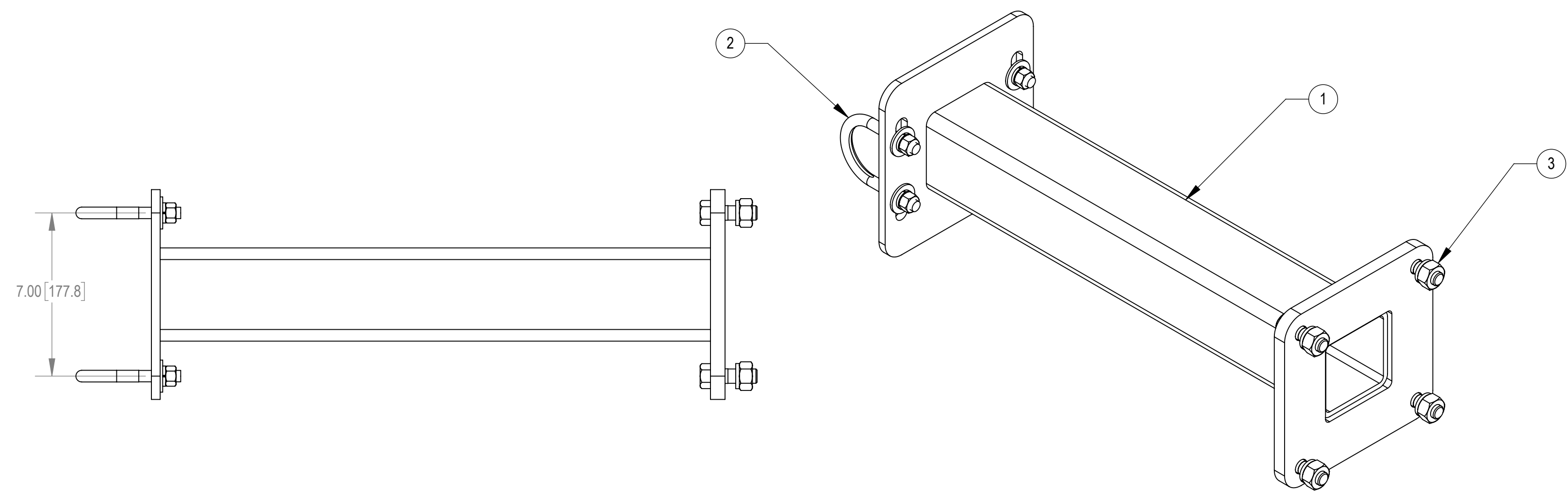

C

C

B

B

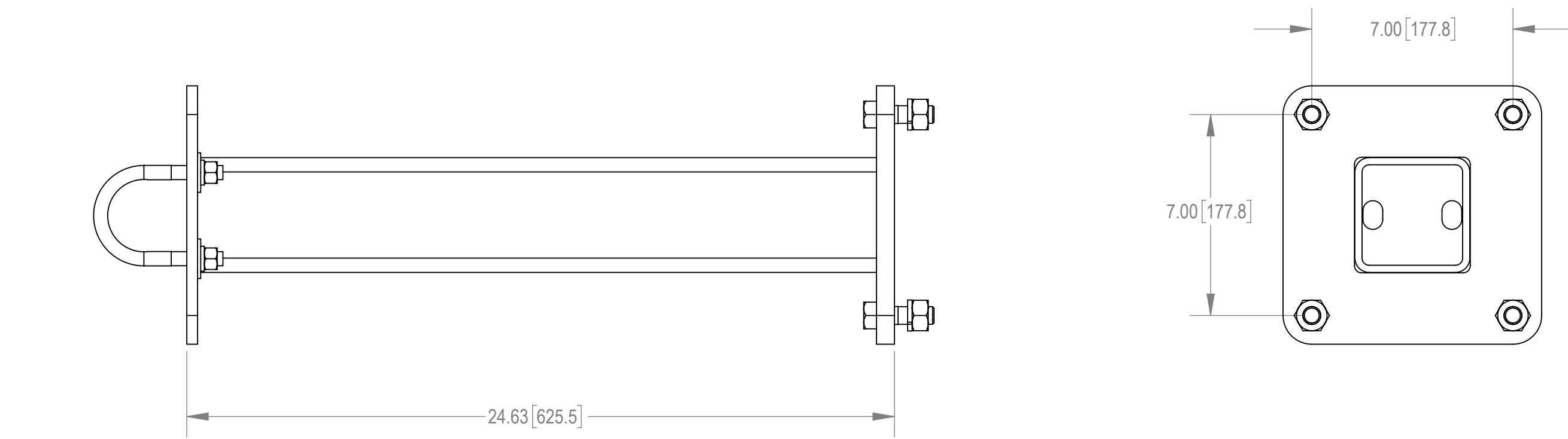

B

B

A

A

ITEM NO.	PART NUMBER	DESCRIPTION	QTY.
1	MCSA24B01	24" STANDOFF WELDMENT	1
2	GUB-4240	1/2" X 2-1/2" X 4" GALV U-BOLT	2
3	GB-0520A	5/8" X 2" GALV BOLT KIT (A325)	4

4

3

2

1

© 2018 CommScope, Inc. Confidential

DENSITY		lbs/in ³
MASS	46.38	lbs
VOLUME	164.17	in ³
SURFACE AREA	1140.49	in ²
HEIGHT		
LENGTH		
WIDTH		

UNLESS OTHERWISE SPECIFIED DIMENSIONS ARE IN INCHES INTERPRET PER ANSI Y 14.5M-1994		NAME	DATE	TITLE				
		CE		24" ANTENNA MOUNT STANDOFF KIT				
		RW	ROGHANSON		10/09/2020			
		RV						
AD	BCAMPBELLCON	10/16/2020						
RE	BCROSS	10/19/2020						
ECN 008000042590		SCALE	DOCUMENT NO.	MC-SA24-B				
SIZE	WORK AREA	24	DRAWING					
C		VERSION	STATUS	REVISION	VERSION	STATUS	REVISION	SHEET
		01	RE		00	RE		1 OF 1

COMMSCOPE, INC. OF NORTH CAROLINA			
TOLERANCES		SAP MATERIAL MASTER	
0 PLACE	X ± .25	2 PLACE	.XX ± 0.06
1 PLACE	.X ± 0.12	ANGLES	± 2°
FINISH		MATERIAL	