

# MHD-FFDH



Hardened Multifiber Optical Connector (HMFOC) cable assembly, HMFOC plug HMFOC plug, 12-fiber

- Hardened connectors are factory-terminated and environmentally sealed for use in optical drop cable deployments
- Hardened drop cables incorporate hardened connector technology that is designed to withstand the rugged outside plant environment
- Hardened drop cables simplify installation and maintenance by reducing splicing requirements in the distribution portion of the network

## Product Classification

<b>Regional Availability</b>	Asia   Latin America   North America
<b>Portfolio</b>	CommScope®
<b>Product Type</b>	Fiber drop cable assembly
<b>Product Series</b>	MHD

## General Specifications

<b>Cable Type</b>	Toneable - Flat
<b>Connector A, quantity</b>	1
<b>Color, boot A</b>	Black
<b>Color, connector A</b>	Black
<b>Connector B, quantity</b>	1
<b>Color, boot B</b>	Black
<b>Color, connector B</b>	Black
<b>Interface, Connector A</b>	Hardened multi-fiber (HMFOC) plug
<b>Interface Feature, connector A</b>	Female   Unpinned
<b>Interface, Connector B</b>	Hardened multi-fiber (HMFOC) plug
<b>Interface Feature, connector B</b>	Female   Unpinned
<b>Jacket Color</b>	Black
<b>Total Fibers, quantity</b>	12

## Dimensions

<b>Cable Assembly Length Range (m)</b>	1 – 750
<b>Cable Assembly Length Range (ft)</b>	50 – 2000

# MHD-FFDH

**Cable Outer Diameter** 4.3 x 9.9 mm (0.17 x 0.39 in)

## Ordering Tree

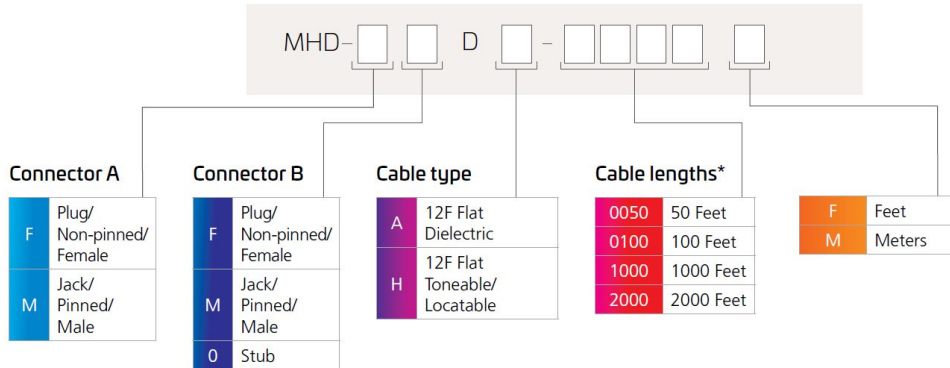

\* Cable Length shown as an example, additional cable lengths available upon request up to 2,000 ft. (600 m).

## Representative Image

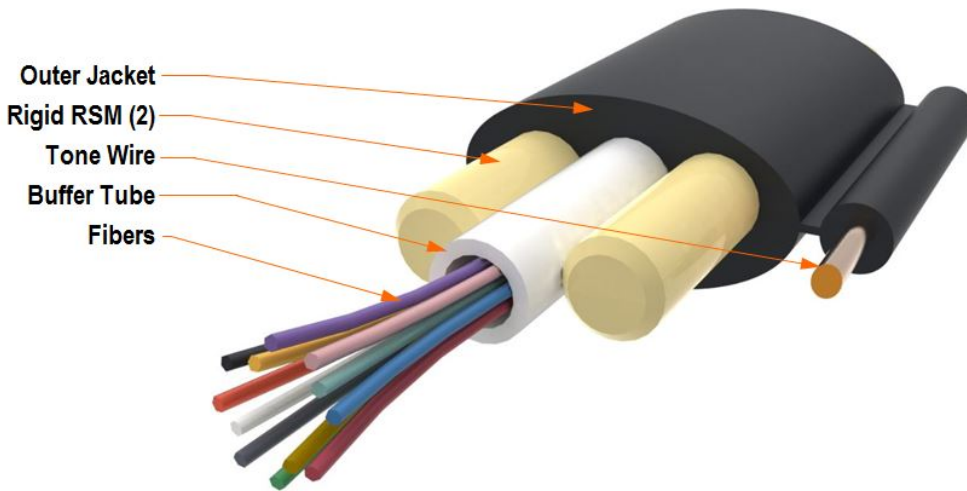

## Mechanical Specifications

<b>Minimum Bend Radius, loaded</b>	86 mm   3.386 in
<b>Minimum Bend Radius, unloaded</b>	81 mm   3.189 in
<b>Tensile Load, long term, maximum</b>	400 N   89.924 lbf
<b>Tensile Load, short term, maximum</b>	1334 N   299.895 lbf

## Optical Specifications

# MHD-FFDH

---

<b>Fiber Mode</b>	Singlemode
<b>Fiber Type</b>	G.657.A2, TeraSPEED®
<b>Insertion Loss, maximum, connector A</b>	0.45 dB
<b>Insertion Loss, maximum, connector B</b>	0.45 dB
<b>Return Loss, minimum, connector A</b>	65 dB
<b>Return Loss, minimum, connector B</b>	65 dB

## Environmental Specifications

<b>Installation temperature</b>	-30 °C to +70 °C (-22 °F to +158 °F)
<b>Operating Temperature</b>	-40 °C to +70 °C (-40 °F to +158 °F)
<b>Storage Temperature</b>	-40 °C to +75 °C (-40 °F to +167 °F)
<b>Environmental Space</b>	Outdoor, buried
<b>Jacket UV Resistance</b>	UV stabilized

## Packaging and Weights

<b>Packaging quantity</b>	1
---------------------------	---

## Regulatory Compliance/Certifications

<b>Agency</b>	<b>Classification</b>
CHINA-ROHS	Below maximum concentration value
REACH-SVHC	Compliant as per SVHC revision on <a href="http://www.commscope.com/ProductCompliance">www.commscope.com/ProductCompliance</a>
ROHS	Compliant
UK-ROHS	Compliant/Exempted



## Included Products

810009374/DB O-012-DF-HY-F12NS/30T /8G1012/1X24AWG	–	Tone Wire Outdoor Drop Cable, 12 fiber Arid Core construction, central loose tube
--	---	---