

MF-511

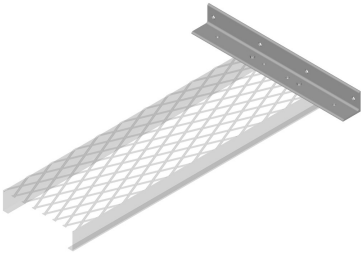

Wall Support Angle, single or double

Product Classification

Product Type Wall mount kit

General Specifications

Application Wall mount

Mounting All bridge channel types

Dimensions

Height 76.2 mm | 3 in

Width 76.2 mm | 3 in

Length 660.4 mm | 26 in

MF-511

Outline Drawing

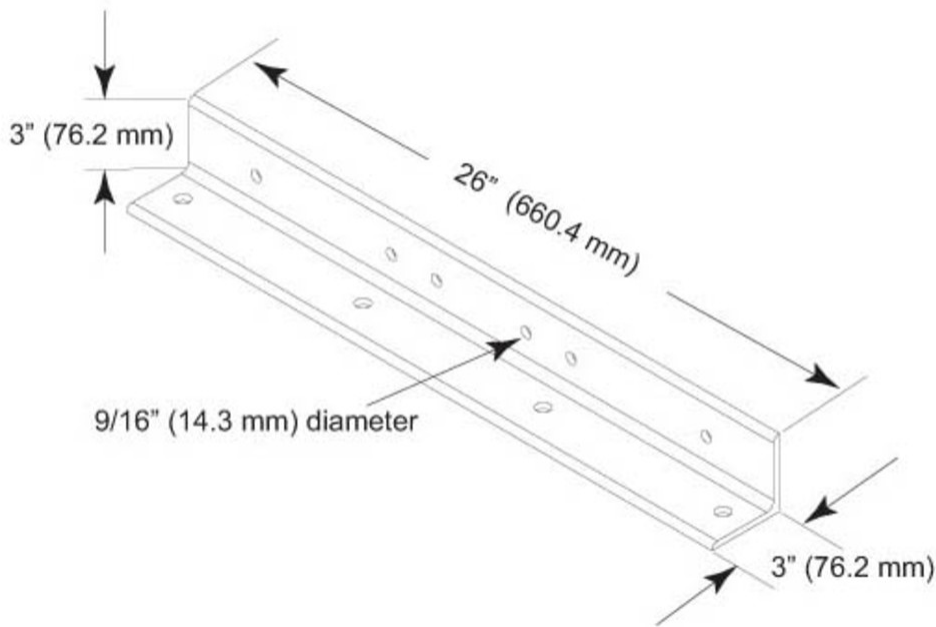

Material Specifications

Material Type Hot dip galvanized steel

Packaging and Weights

Included Angle brackets

Packaging quantity 1

Weight, net 5 kg | 11.023 lb

Regulatory Compliance/Certifications

Agency

CHINA-ROHS

ISO 9001:2015

ROHS

UK-ROHS

Classification

Above maximum concentration value

Designed, manufactured and/or distributed under this quality management system

Compliant/Exempted

Compliant/Exempted

