

DM-100

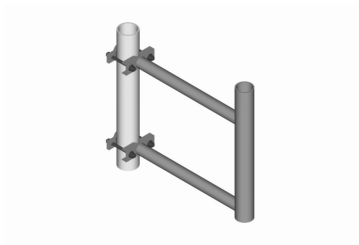

Microwave Antenna Stand-Off Bracket, 24 in

Product Classification

Product Type Stand-off mount

General Specifications

Mounting Straight or tapered legs up to 88.9 mm (3-1/2 in) OD

Tower Taper Non-tapered | Tapered

Dimensions

Height 609.6 mm | 24 in

Width 152.4 mm | 6 in

Length 609.6 mm | 24 in

Stand-off Distance 609.6 mm | 24 in

DM-100

Outline Drawing

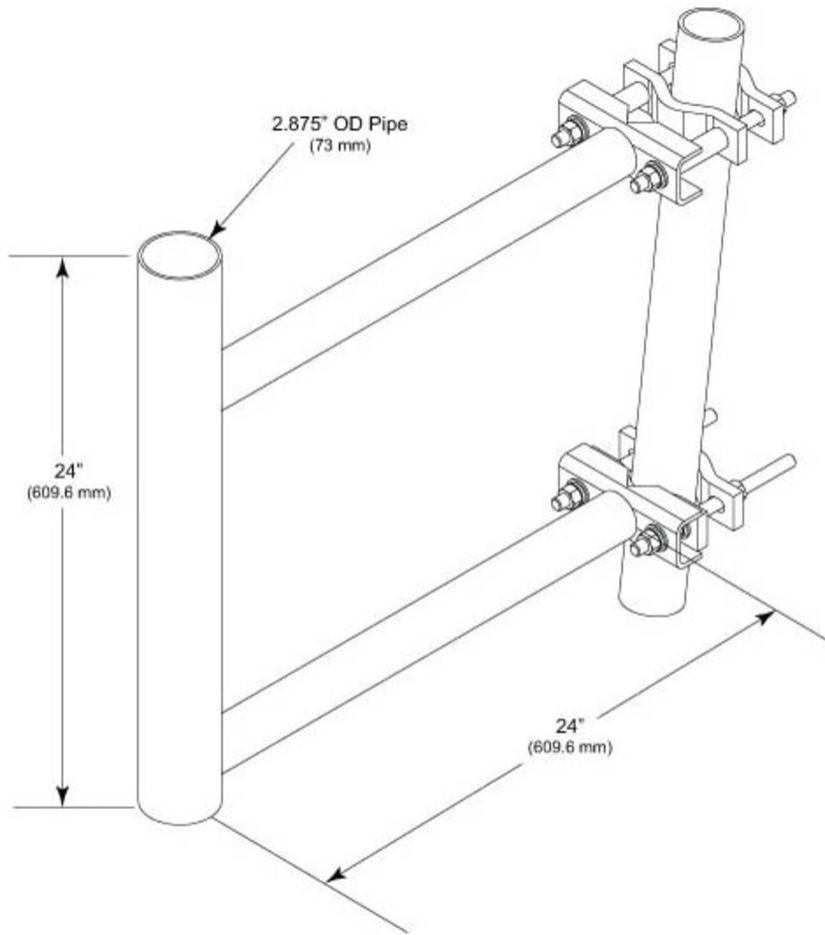

Material Specifications

Material Type Hot dip galvanized steel

Packaging and Weights

Included Clamps | Stand-off

Packaging quantity 1

Weight, net 14.3 kg | 31.526 lb

Regulatory Compliance/Certifications

Agency **Classification**

DM-100

CHINA-ROHS	Below maximum concentration value
ISO 9001:2015	Designed, manufactured and/or distributed under this quality management system
REACH-SVHC	Compliant as per SVHC revision on www.andrew.com/ProductCompliance
ROHS	Compliant
UK-ROHS	Compliant

