

C085SFPM

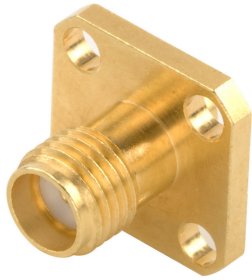

SMA Female Panel Mount for 0.085 in CF085-50 cable

Product Classification

Product Type	Wireless and radiating connector
Product Series	CF085-50

General Specifications

Body Style	Panel mount
Cable Family	CF085-50
Inner Contact Attachment Method	Solder
Inner Contact Plating	Gold
Interface	SMA Female
Mounting Angle	Straight
Outer Contact Attachment Method	Solder
Outer Contact Plating	Gold
Pressurizable	No

Dimensions

Height	16 mm 0.63 in
Width	16 mm 0.63 in
Length	12.7 mm 0.5 in
Diameter	16 mm 0.63 in

Outline Drawing

C085SFPM

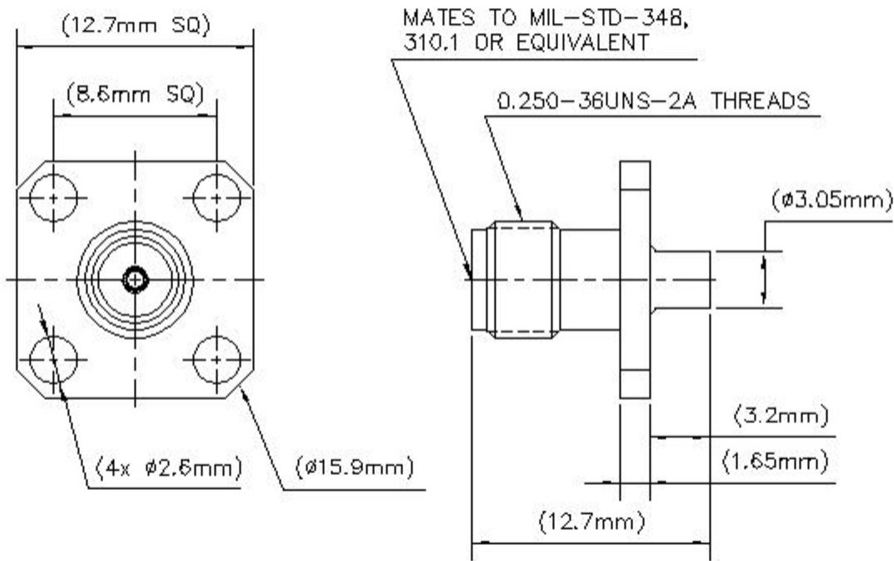

Electrical Specifications

3rd Order IMD at Frequency	-112 dBm @ 910 MHz
3rd Order IMD Test Method	Two +43 dBm carriers
Average Power at Frequency	0.2 kW @ 900 MHz
Cable Impedance	50 ohm
Connector Impedance	50 ohm
dc Test Voltage	1000 V
Inner Contact Resistance, maximum	3 mOhm
Insulation Resistance, minimum	5000 MOhm
Operating Frequency Band	0 – 6000 MHz
Outer Contact Resistance, maximum	2.5 mOhm
Peak Power, maximum	0.21 kW
RF Operating Voltage, maximum (vrms)	500 V
Shielding Effectiveness	-100 dB

VSWR/Return Loss

Frequency Band	VSWR	Return Loss (dB)
824–2700 MHz	1.065	30.04
3000–6000 MHz	1.29	18

C085SFPM

Mechanical Specifications

Insertion Force	97.86 N 22 lbf
Insertion Force Method	IEC 61169-16:9.3.5
Interface Durability	500 cycles
Interface Durability Method	IEC 61169-4:17
Mechanical Shock Test Method	IEC 60068-2-27

Environmental Specifications

Operating Temperature	-55 °C to +85 °C (-67 °F to +185 °F)
Storage Temperature	-65 °C to +125 °C (-85 °F to +257 °F)
Attenuation, Ambient Temperature	20 °C 68 °F
Average Power, Ambient Temperature	40 °C 104 °F
Average Power, Inner Conductor Temperature	100 °C 212 °F
Corrosion Test Method	IEC 60068-2-11
Immersion Depth	1 m
Immersion Test Mating	Mated
Immersion Test Method	IEC 60529:2001, IP68
Moisture Resistance Test Method	IEC 60068-2-3
Thermal Shock Test Method	IEC 60068-2-14
Vibration Test Method	IEC 60068-2-6

Packaging and Weights

Weight, net	3.01 g 0.007 lb
--------------------	-------------------

Regulatory Compliance/Certifications

Agency	Classification
CHINA-ROHS	Below maximum concentration value
ISO 9001:2015	Designed, manufactured and/or distributed under this quality management system
REACH-SVHC	Compliant as per SVHC revision on www.commscope.com/ProductCompliance
ROHS	Compliant



C085SFPM

* Footnotes

Immersion Depth Immersion at specified depth for 24 hours