

### FPX Series 3, 4 & 5 Rack Unit Fiber Panel

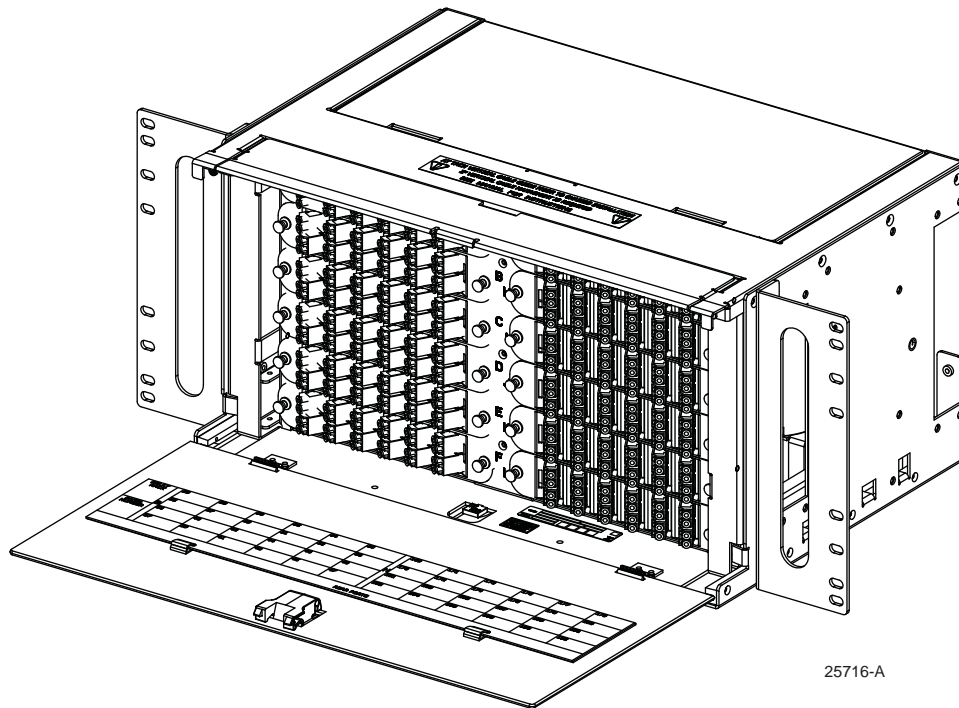

5RU FPX Panel

Content	Page
INTRODUCTION .....	2
1 DESCRIPTION .....	3
2 BASIC INSTALLATION .....	5
2.1 Mounting Bracket Options .....	5
2.2 Installing the Panel on an Equipment Rack .....	6
2.3 Installing Vertical Cable Guides .....	7
2.4 Grounding the Panel .....	8
3 PANEL-SPECIFIC INSTALLATION PROCEDURES .....	9
3.1 Panel Types and Procedures Done for Each Type .....	9
3.2 Installing Adapter Packs (LC, SC, or MPO) .....	9
3.3 Installing MPO Cassettes .....	10
3.4 Installing an MPO Cable With MPO Cassettes .....	13
3.5 Installing a Cable Clamp .....	16
3.6 Preparing and Connecting a Pre-Connectorized Cable Assembly .....	17
3.7 Installing Pigtail Adapter Pack Assemblies and Splice Trays .....	21
3.8 Routing an IFC/OSP Cable .....	25
	(continued)

Content	Page
3.9 Performing a Ribbon Fiber Heat Fusion Splice . . . . .	29
4 OPERATION . . . . .	31
4.1 Accessing Inner Panel . . . . .	31
4.2 Removing Fanout Holders to Gain Access to Splice Trays . . . . .	33
5 CUSTOMER INFORMATION AND ASSISTANCE . . . . .	34

## INTRODUCTION

This manual provides a description of the 12-inch-deep 3, 4, & 5 Rack Unit (3, 4, & 5 RU) FPX Series Fiber Panel plus the installation and cable routing procedures.

## Revision History

ISSUE	DATE	REASON FOR CHANGE
1	2/2015	Original
2	July 2016	Rebranded for CommScope.
Rev C	May 2018	Revised cable routing instructions and diagrams.

## Trademark Information

CommScope is a registered trademark of CommScope Inc.

## Admonishments

Important safety admonishments are used throughout this manual to warn of possible hazards to persons or equipment. Admonishments — in the form of Dangers, Warnings, and Cautions, — must be followed at all times.



**Danger:** *Danger is used to indicate the presence of a hazard that will cause severe personal injury, death, or substantial property damage if the hazard is not avoided.*



**Warning:** *Warning is used to indicate the presence of a hazard that can cause severe personal injury, death, or substantial property damage if the hazard is not avoided.*



**Caution:** *Caution is used to indicate the presence of a hazard that will or can cause minor personal injury or property damage if the hazard is not avoided.*

## General Safety Precautions



**Caution:** *Fiber optic cables may be damaged if bent or curved to a radius that is less than the recommended minimum bend radius. Always observe the recommended bend radius limit when installing fiber optic cables and patch cords.*



**Danger:** Exposure to laser radiation can seriously damage the retina of the eye. Do not look into the ends of any optical fiber. Do not assume the laser power is turned-off or that the fiber is disconnected at the other end.



**Caution:** Improper handling can damage fiber optic cables. Do not bend fiber optic cable more sharply than the minimum recommended bend radius specified by the cable manufacturer. Do not apply more pulling force to the cable than specified. Do not compress the fiber or allow it to kink.

## 1 DESCRIPTION

- **Note:** The FPX panel is designed to be installed in an environmentally controlled network telecommunications facility such as a Central Office, Controlled Environmental Vault, or Data Center.

The 3, 4, & 5 RU FPX fiber panel, shown in [Figure 1](#), can accommodate up to 144, 192, or 288 LC terminations, respectively (72, 96, and 144 per side, respectively). This panel may be ordered empty or with adapter packs, Multifiber Push-On (MPO) cassettes, splice trays, or pigtails. The panel can be configured for termination only (without splice trays) or for termination/splice. [Figure 1](#) shows a front view of the panel.

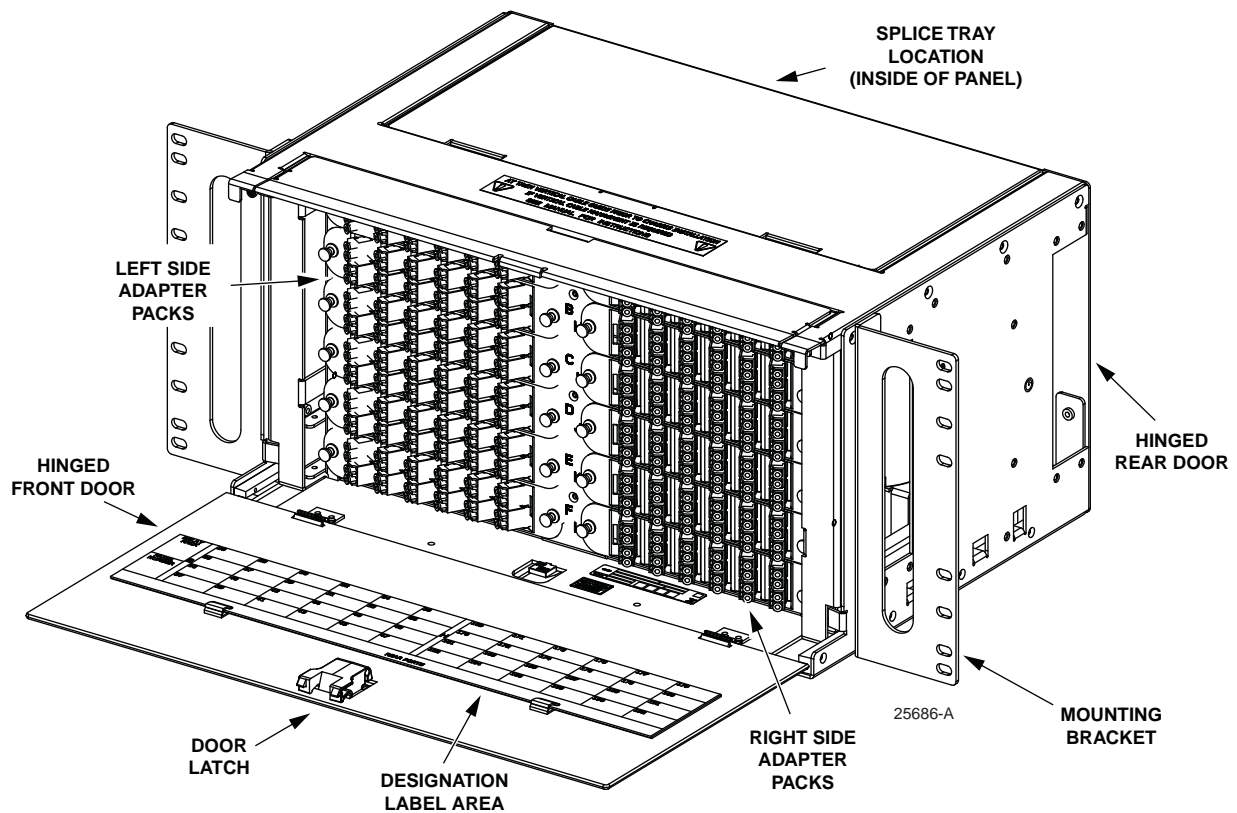

Figure 1. Typical FPX Fiber Panel Configured With Adapter Packs (5RU Front View Shown)

The FPX fiber panel can be ordered loaded with adapter packs only, or loaded with both adapter packs and a pre-terminated, factory-installed cable. While not recommended, field-installed connectors may be accommodated depending on boot length.

The panel can be used in either singlemode or multimode applications, and with either stranded or ribbon cable. Cables can be either Intra Facility Fiber (IFC) or Outside Plant (OSP). [Figure 2](#) shows a rear view of the panel in a pre-terminated configuration.

Termination/Splice panels have splice trays mounted inside the panel for easy access and cable routing. The panel accommodates LC/SC adapter packs, MPO adapter packs, and MPO cassettes. Radius limiters located inside the panel must be removed prior to panel installation when using MPO cassettes.

When a panel is ordered loaded with adapters, a fanning tree such as shown in [Figure 2](#) is included. The fanning tree is used to support the fibers routed to the adapters.

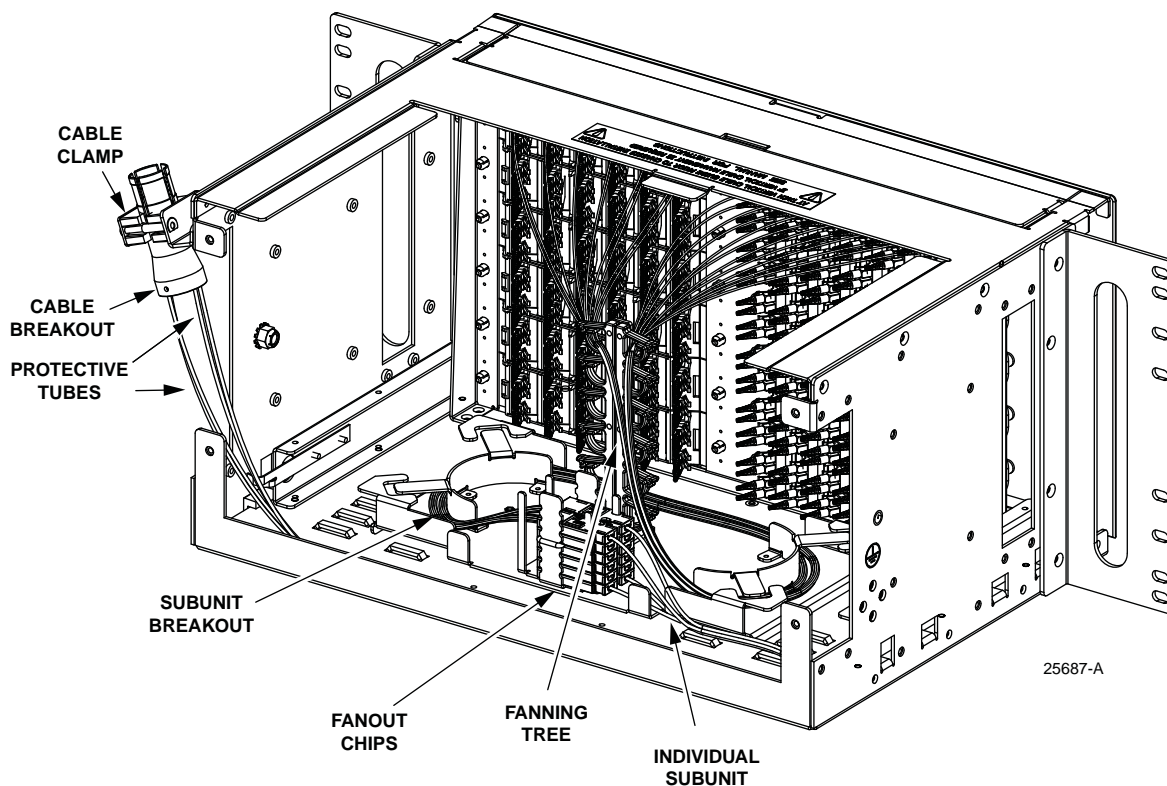

Figure 2. Pre-Terminated 5RU FPX Panel Example



## 2 BASIC INSTALLATION

Basic installation consists of procedures done for every type of FPX fiber panel, selecting the mounting bracket location and reconfiguring the brackets if desired, installing the panel on an equipment rack, installing the vertical cable guides, and grounding the panel. Instructions for these procedures are provided below.



**Warning:** *Never install equipment in a wet location or during a lightning storm. When installing or modifying communication lines, disconnect lines at the network interface before working with uninsulated lines or terminals.*

### 2.1 Mounting Bracket Options

The panel is shipped with mounting brackets configured for a 23-inch EIA/WECO rack with a 2-inch recess. The panel can be mounted with a 2, 5, or 8 -inch recess in 19 or 23-inch racks using EIA or WECO mounting hole patterns. [Figure 3](#) shows the available mounting options.

► **Note:** The FPX panel is designed to be installed in an environmentally controlled network telecommunications facility such as a Central Office, Controlled Environmental Vault, or Data Center.

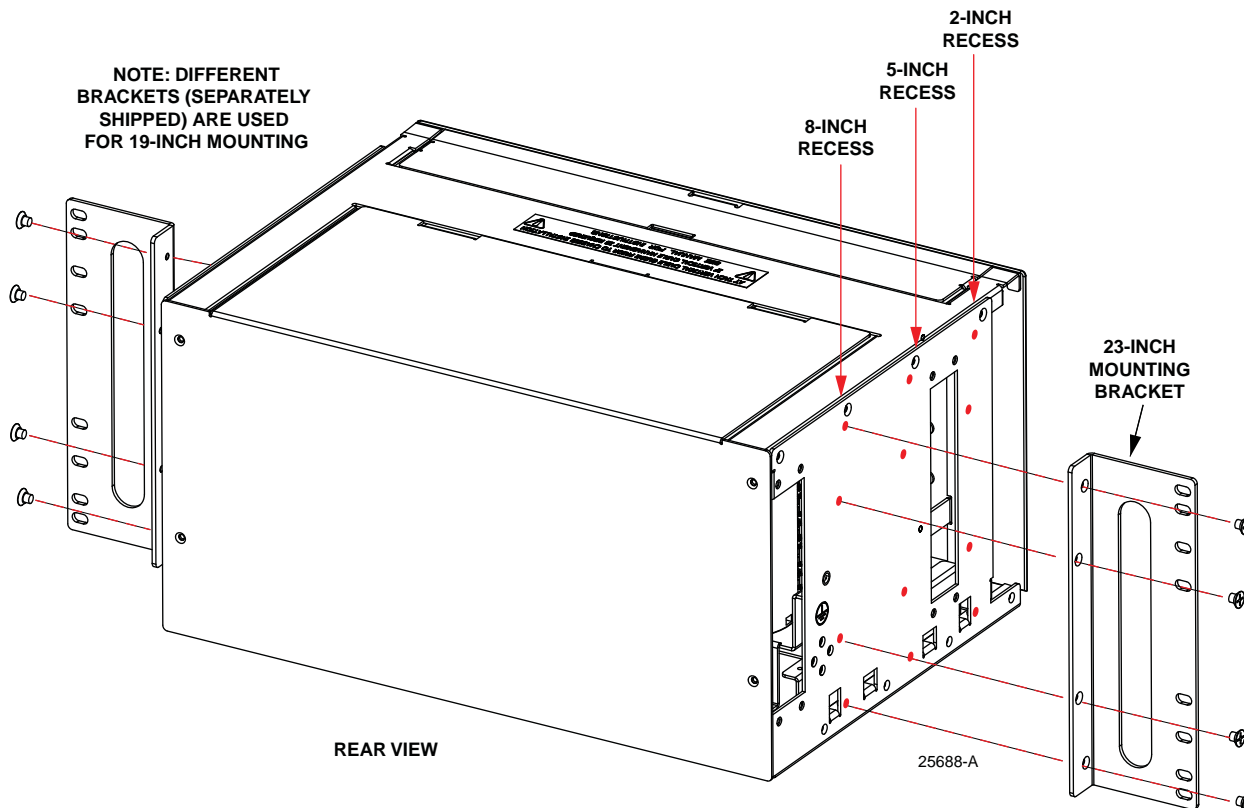

Figure 3. Mounting Options (5RU Panel Shown)

## 2.2 Installing the Panel on an Equipment Rack

Use 12-24 screws to secure the panel to an equipment rack as shown in [Figure 4](#).

► **Note:** [Figure 4](#) shows a panel installed in a 23-inch rack with a 2-inch recess.

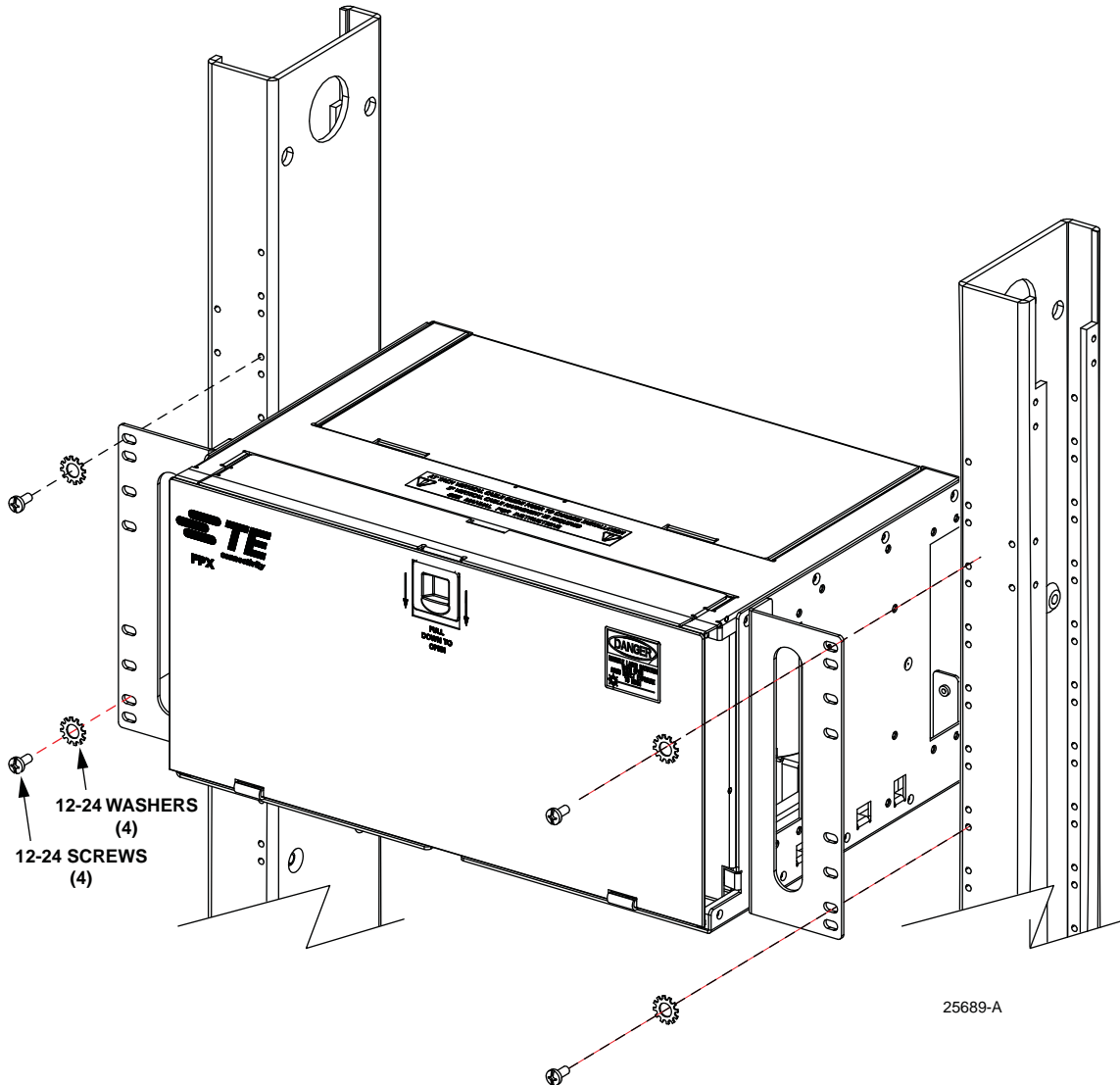

Figure 4. Install Panel into Rack (5RU Panel Shown)

## 2.3 Installing Vertical Cable Guides

Install the two Vertical Cable Guides (VCGs) on the panel as follows, referring to [Figure 5](#):

1. Align the slotted mounting holes in the cable shield with the holes in the VCG mounting bracket.
2. Align the holes in VCG with the holes in the cable shield and mounting bracket. Use 6-32 screws (2 per VCG, provided) to secure the VCG's to panel.

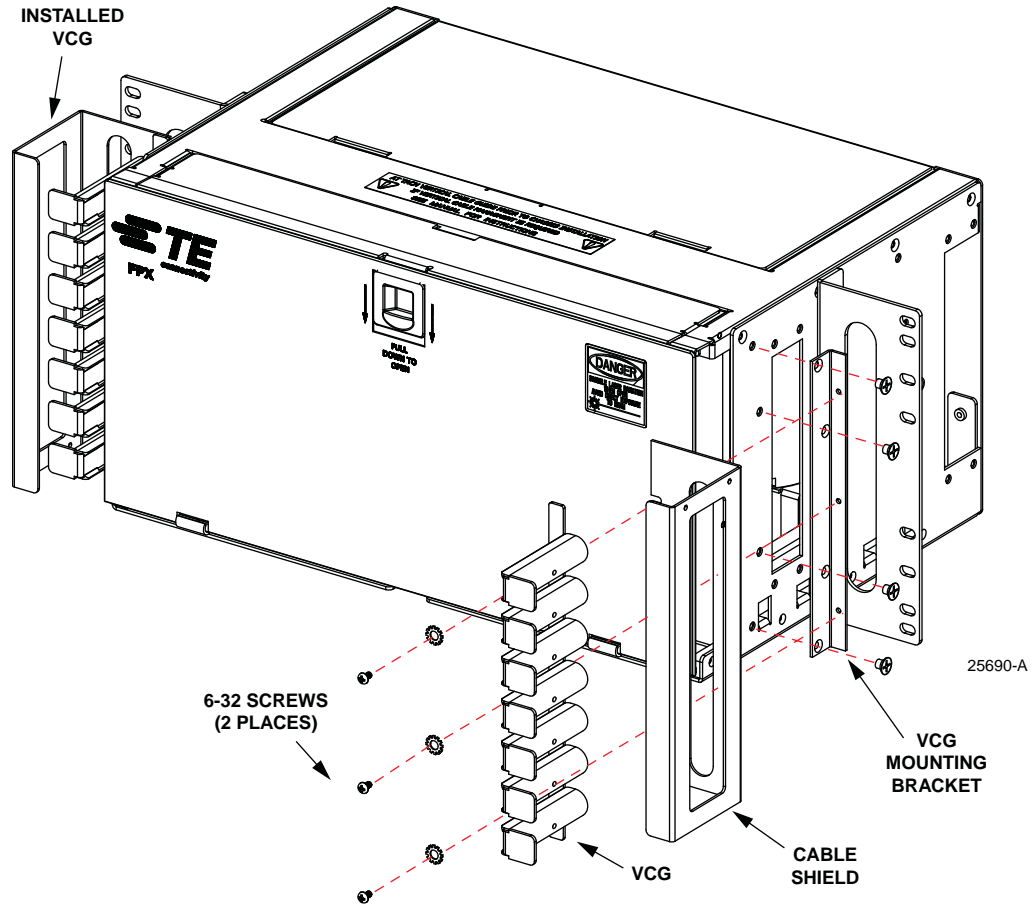

Figure 5. Install VCGs (5RU Panel Shown)

## 2.4 Grounding the Panel

Each FPX fiber panel has a grounding location on each side of the panel marked by a standard grounding symbol as indicated in [Figure 6](#). Just below this location are four mounting holes for securing a two-hole lug such as shown in [Figure 7](#). The lug may be mounted in either a horizontal or vertical orientation. Secure the lug using the two #10-32 ground screws and two #10 star washers provided. Route a #6 copper grounding cable from the lug to office ground.

► **Note:** Ground the unit to the local facility CBN (Common Bonding Network) or IBN (Isolated Bonding Network) per local practice.

If installing an armored OSP cable, use the internal grounding stud (shown in [Figure 6](#)) to ground the metallic sheath within the cable.

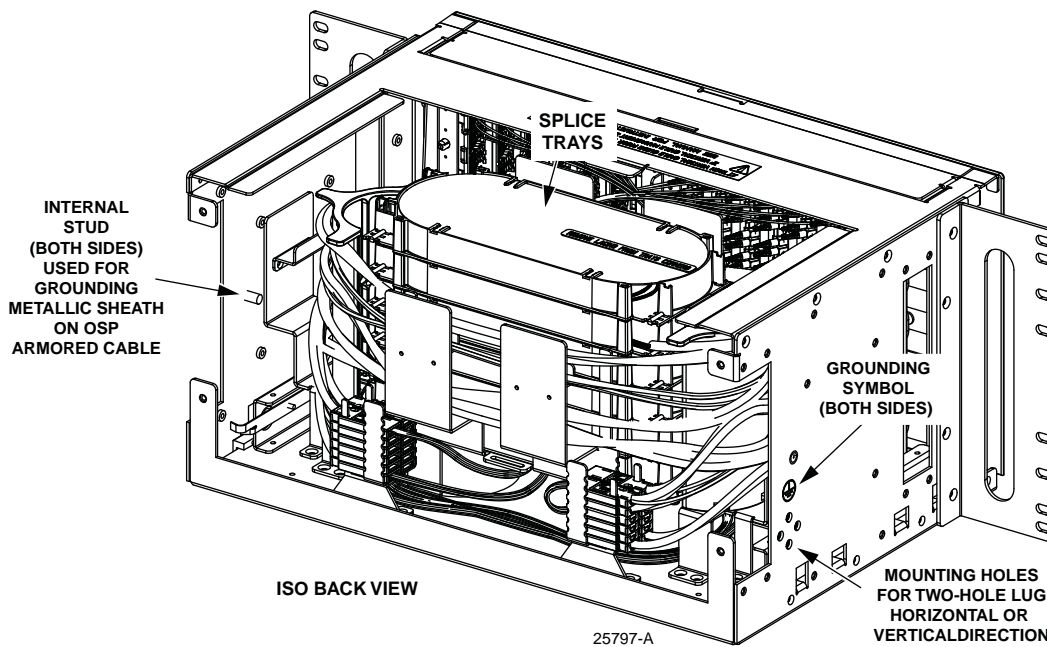

Figure 6. Grounding Location (Rear View of 5RU Panel)

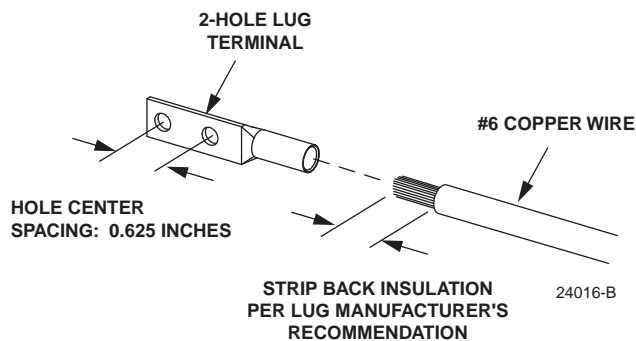

Figure 7. Ground Cable and 2-Hole Lug Terminal

### 3 PANEL-SPECIFIC INSTALLATION PROCEDURES

For purposes of installation, the FPX fiber panel is divided into four types:

- Empty panel (includes rear management hardware to accept adapter packs, pigtails, and splice trays);
- Termination panel loaded with adapters only (includes rear management hardware to accept multi-fiber cable assemblies);
- Termination/splice panel: loaded with adapters, pigtails, and splice trays;
- Stubbed panel: completely equipped with a preterminated cable stub.

#### 3.1 Panel Types and Procedures Done for Each Type

Table 1 lists the main panel types shipped to the customer and the installation procedures that may be done for each type.

Table 1. Panel Types and Procedures Required

PANEL TYPE	PROCEDURE	REFER TO SECTION
Empty Panel	Basic installation	2 on Page 5
	Install adapter packs (LC, SC, or MPO)	3.2 on Page 9
	Install MPO cassettes	3.3 on Page 10
	Install an MPO cable with MPO cassettes	3.4 on Page 13
	Install a cable clamp	3.5 on Page 16
	Prepare and connect a pre-connectorized cable assembly	3.6 on Page 17
	Install pigtail adapter pack assemblies and splice trays	3.7 on Page 21
	Install an IFC/OSP cable and prepare for splicing	3.8 on Page 25
Termination Only Panel	Basic installation	2 on Page 5
	Prepare and connect a pre-connectorized cable assembly	3.6 on Page 17
Termination/Splice Panel	Basic installation	2 on Page 5
	Install pigtail adapter pack assemblies and splice trays	3.7 on Page 21
	Install an IFC/OSP cable and prepare for splicing	3.8 on Page 25
Stub cable	Basic installation	2 on Page 5

#### 3.2 Installing Adapter Packs (LC, SC, or MPO)

This section describes how to install adapter packs (LC, SC, or MPO) in an empty FPX panel. The 3RU panel accepts up to six adapter packs. The 4RU panel accepts up to eight adapter packs. The 5RU panel accepts up to 12 adapter packs. Use the following procedure.

1. Orient the adapter pack as shown in [Figure 8](#).

► **Note:** Adapter packs installed on left side of panel are angled toward the left. Adapter packs on right side are angled towards the right.

2. Align the adapter pack with the receptor holes at its designated location. Pull out the Nylatch plunger fasteners and press them into the receptor holes until they lock into place.

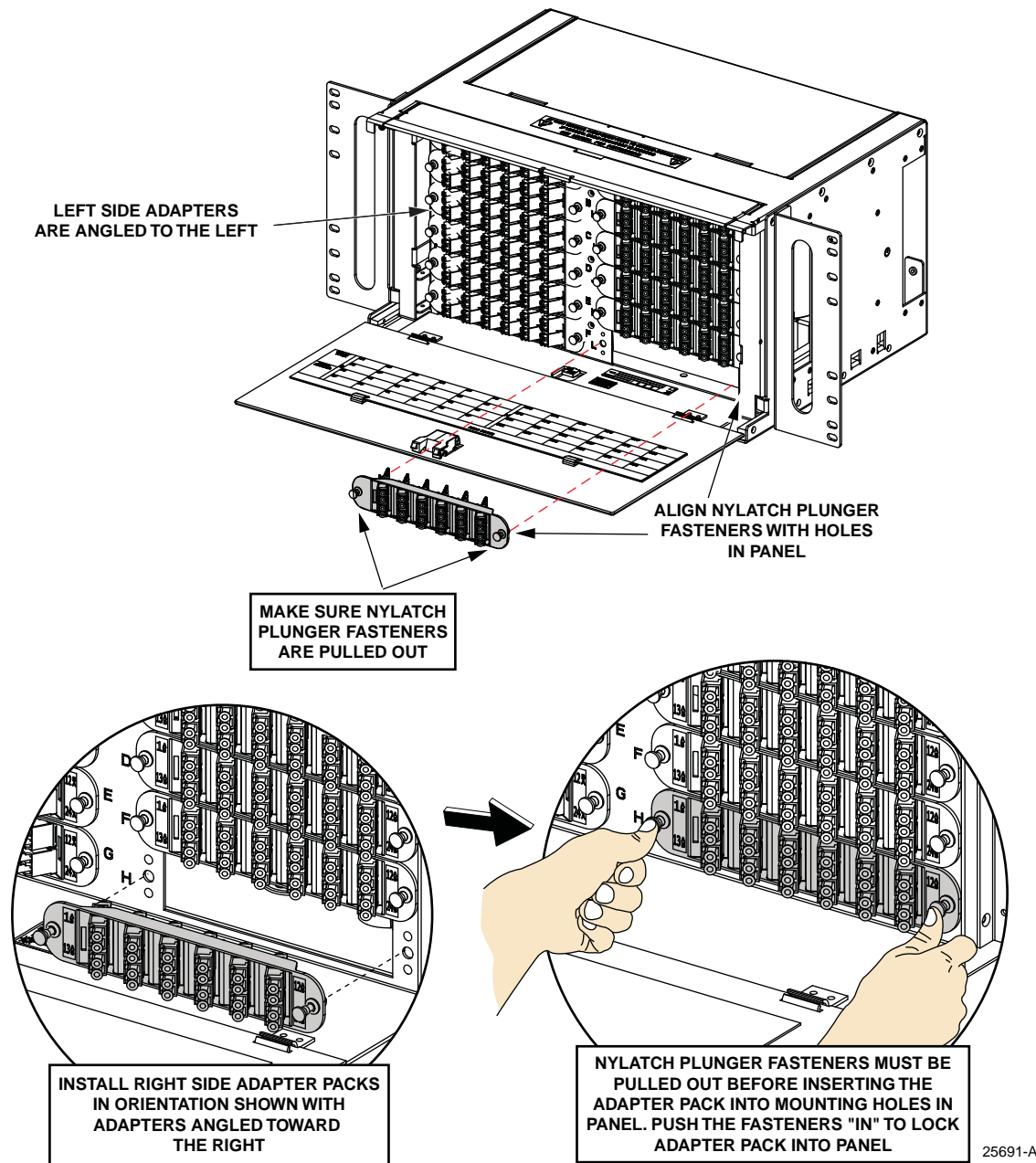

Figure 8. Adapter Pack Installation (5RU Panel Shown)

### 3.3 Installing MPO Cassettes

This section describes how to install MPO cassettes in an empty FPX panel. The 3RU panel accepts up to six cassettes. The 4RU panel accepts up to eight cassettes. The 5RU panel accepts

up to 12 cassettes. Before installing MPO cassettes, other components must be removed from the empty panel. Use the following procedure.

1. Using a Phillips screwdriver, remove the components shown in [Figure 9](#):
  - a. Splice tray holder base;
  - b. Radius limiters (quantity 2).

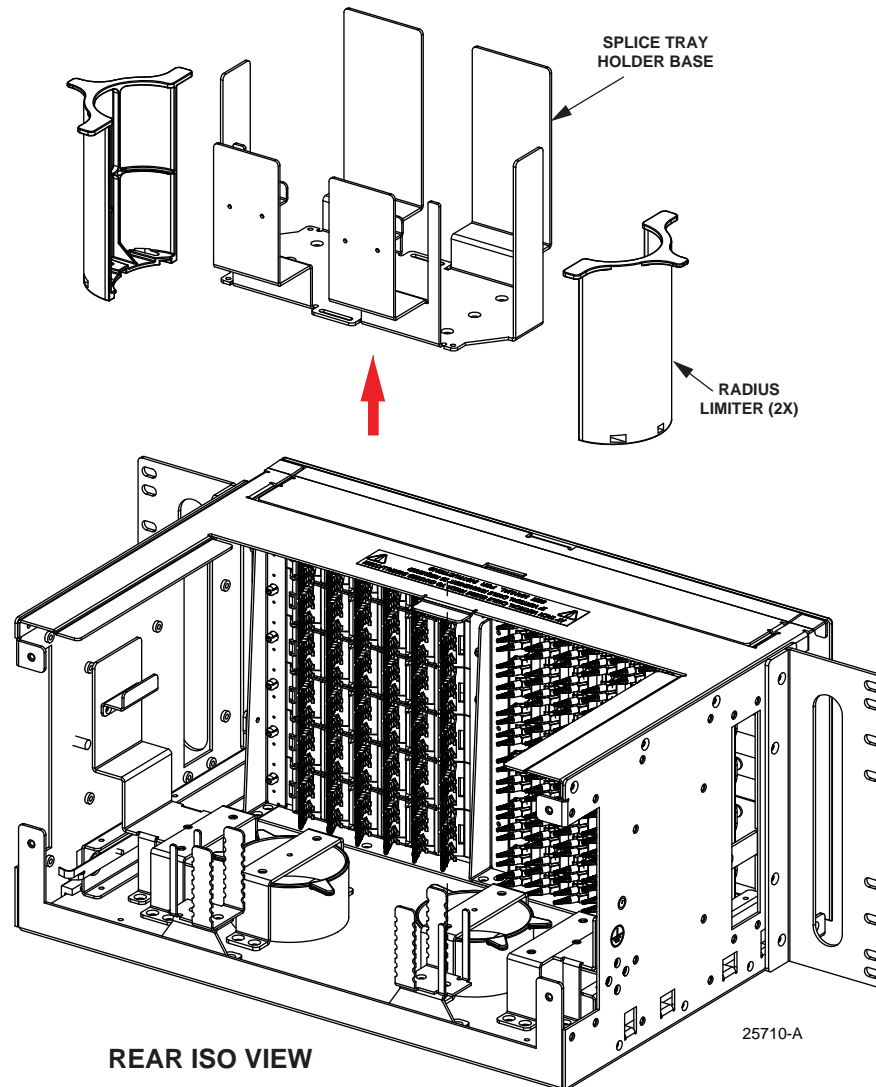

Figure 9. Removing Splice Tray Holder Base and Radius Limiters (5RU Panel Rear View)

2. Using a Phillips screwdriver, remove the additional components shown in [Figure 10](#):
  - a. Support fiber bracket (quantity 4);
  - b. Fanout holder (quantity 2);
  - c. Fanout holder base (quantity 2);



- d. Splice tray holder bracket (quantity 2);
- e. Radius limiter support bracket (quantity 2)
- f. Radius limiter (quantity 2).

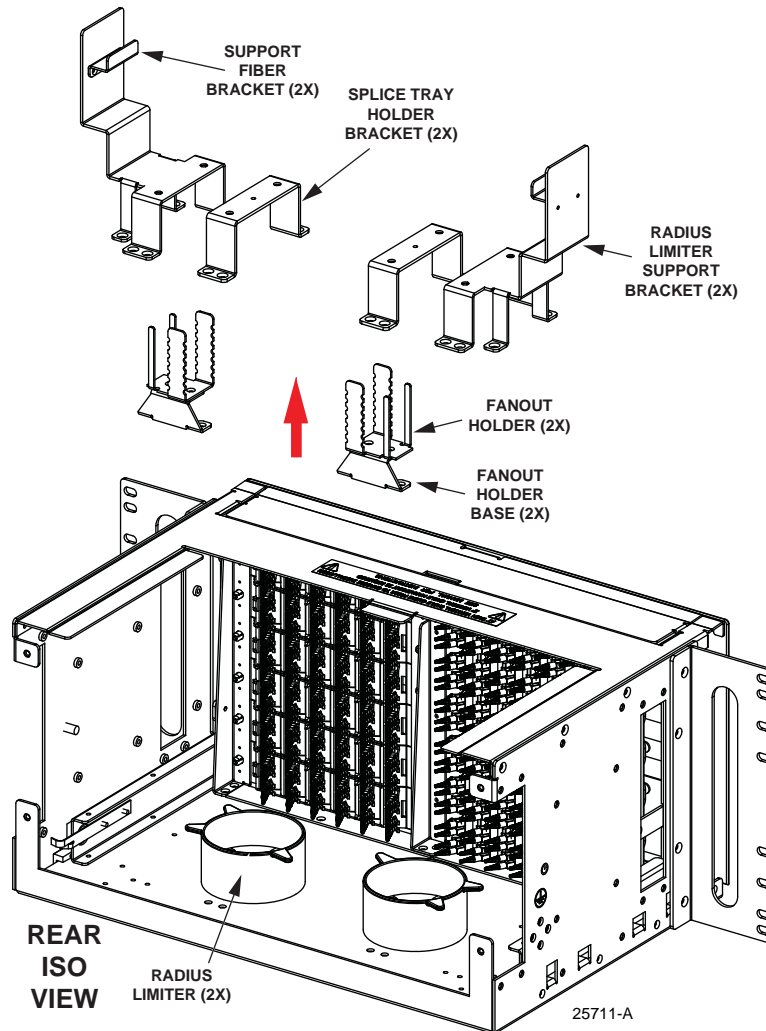

Figure 10. Removing Additional Components (5RU Panel Rear View)

3. Install the MPO cassettes in the orientation shown in [Figure 11](#). Note that the cassettes installed on the left side of the panel are angled toward the left, cassettes on the right side are angled towards the right.
- **Note:** After a panel has been modified to hold MPO cassettes, it must not be used with standard adapter packs. The components that were removed to allow installation of the MPO cassettes provide essential cable management functions when routing pigtailed to the rear side of standard adapter packs.

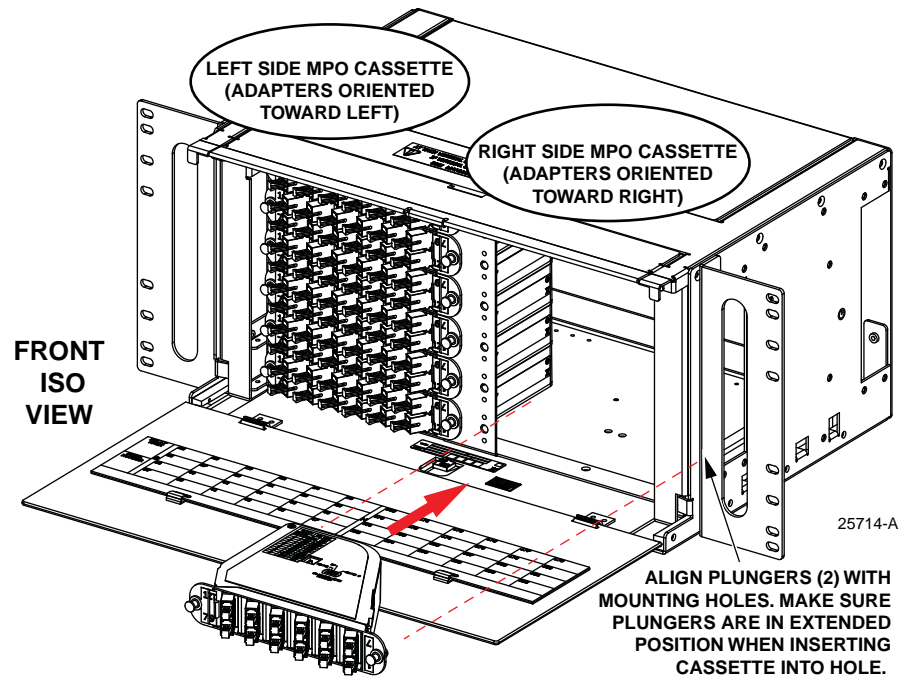

Figure 11. Installing MPO Cassettes (5RU Panel Front View)

### 3.4 Installing an MPO Cable With MPO Cassettes

This section tells how to how to route and connect an MPO cable with MPO cassettes in an empty FPX panel. Before installing the cassettes, other components must be removed from the empty panel as described in the previous procedure. Use the following procedure.

1. Using a Phillips screwdriver, remove the components shown in [Figure 9 on Page 11](#) and [Figure 10 on Page 12](#). Included are the following:
  - a. Splice tray holder base;
  - b. Radius limiters (quantity 2).
  - c. Support fiber bracket (quantity 4);
  - d. Fanout holder (quantity 2);
  - e. Fanout holder base (quantity 2);
  - f. Splice tray holder bracket (quantity 2);
  - g. Radius limiter support bracket (quantity 2)
  - h. Radius limiters (quantity 2).
2. Determine the cable entry location. Cables may enter the panel from either the top or bottom, and may be clamped to either the left or right side, as shown in [Figure 12](#), [Figure 13](#), [Figure 14](#), and [Figure 15](#).

3. Install the MPO cassettes in the panel bulkhead in an orderly manner per local standards.
4. Secure the cable with a cable clamp. For cable clamp details, refer to [Section 3.5 on Page 16](#). Route the cable as shown in the appropriate figure ([Figure 12](#), [Figure 13](#), [Figure 14](#), or [Figure 15](#)).

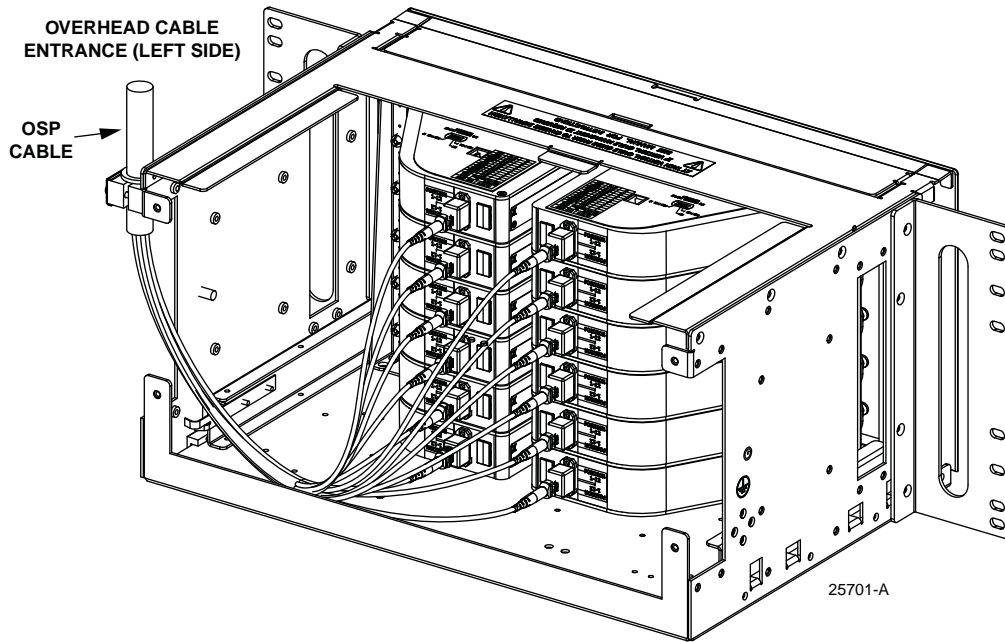

Figure 12. Overhead, Left Side MPO Cable Entrance (5RU Panel With MPO Cassettes)

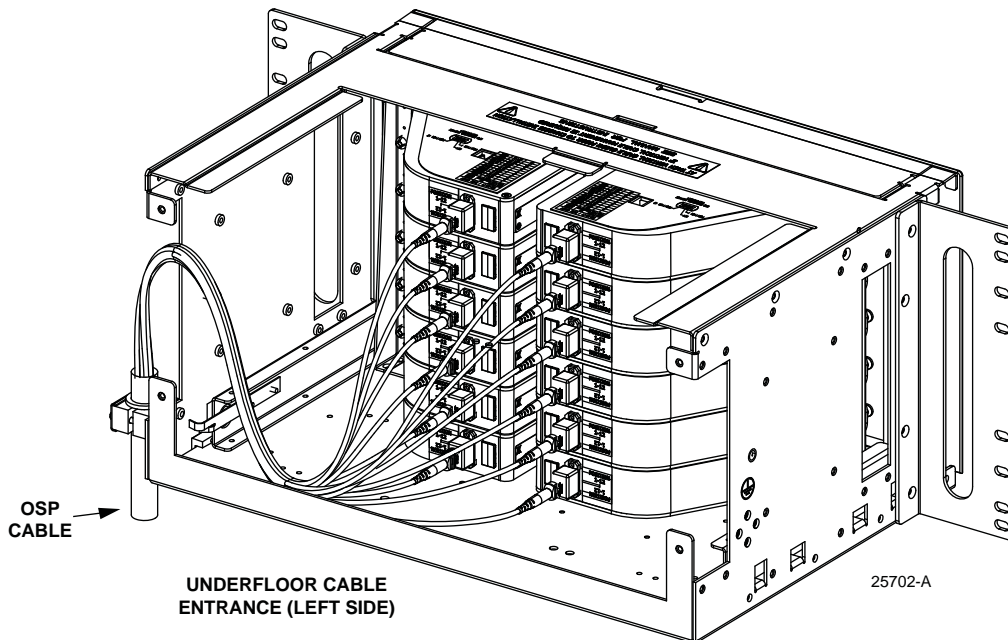

Figure 13. Underfloor, Left Side MPO Cable Entrance (5RU Panel With MPO Cassettes)

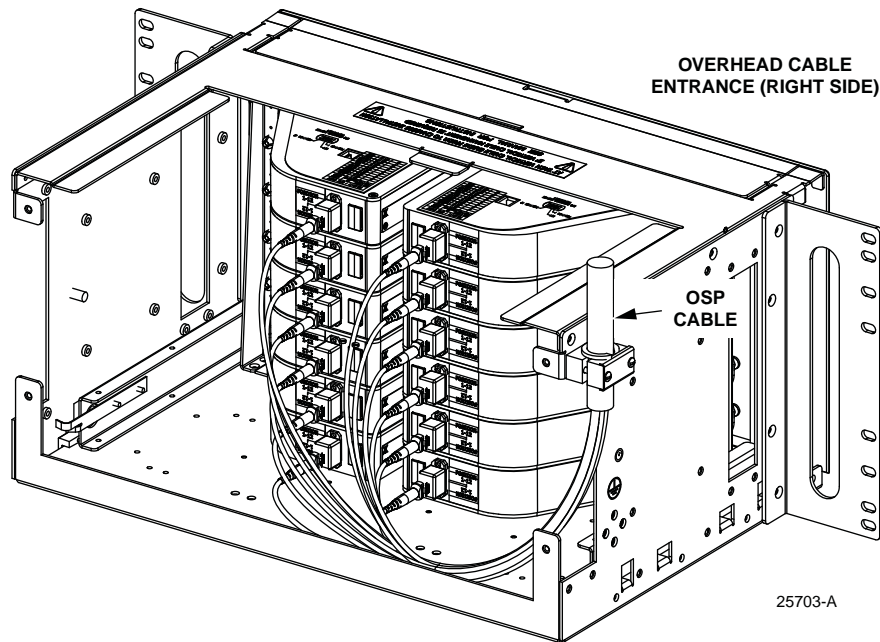

Figure 14. Overhead, Right Side MPO Cable Entrance (5RU Panel With MPO Cassettes)

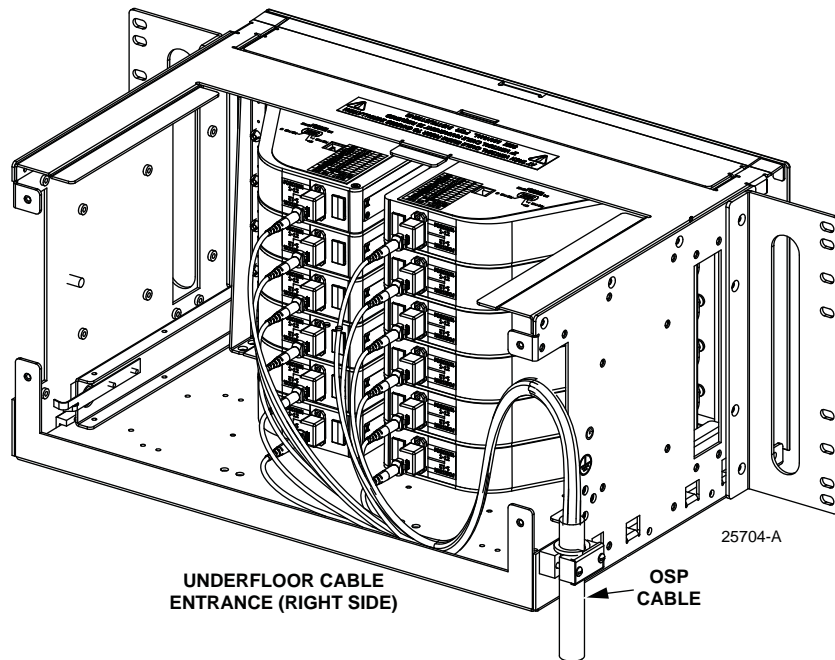

Figure 15. Underfloor, Right Side MPO Cable Entrance (5RU Panel With MPO Cassettes)

### 3.5 Installing a Cable Clamp

Cables may enter the panel from the rear left or rear right side in either a top or bottom location as shown in multiple places in this manual. Two cable clamps are provided. Often only one cable clamp is used. The provided clamp, shown exploded in [Figure 16](#), accommodates cables with an outer diameter of 0.4 to 0.8 inches (1.02 to 2.03 cm). A larger clamp is available from TE for cables with an outer diameter of 0.8 to 1.2 inches (2.03 to 3.05 cm). Cable clamps of an appropriate size are provided with TE IFC cables. Additional clamps can be ordered as accessories.

► **Note:** When two cables enter from the same location, two cable clamp assemblies can be stacked as shown in [Figure 17](#).

Use the following procedure to install a cable clamp.

1. Determine in the cable entrance location.
2. Refer to the appropriate procedure in this manual for routing cable to and within the panel.
3. Install the cable clamp as shown in [Figure 16](#) (or [Figure 17](#) if stacked).

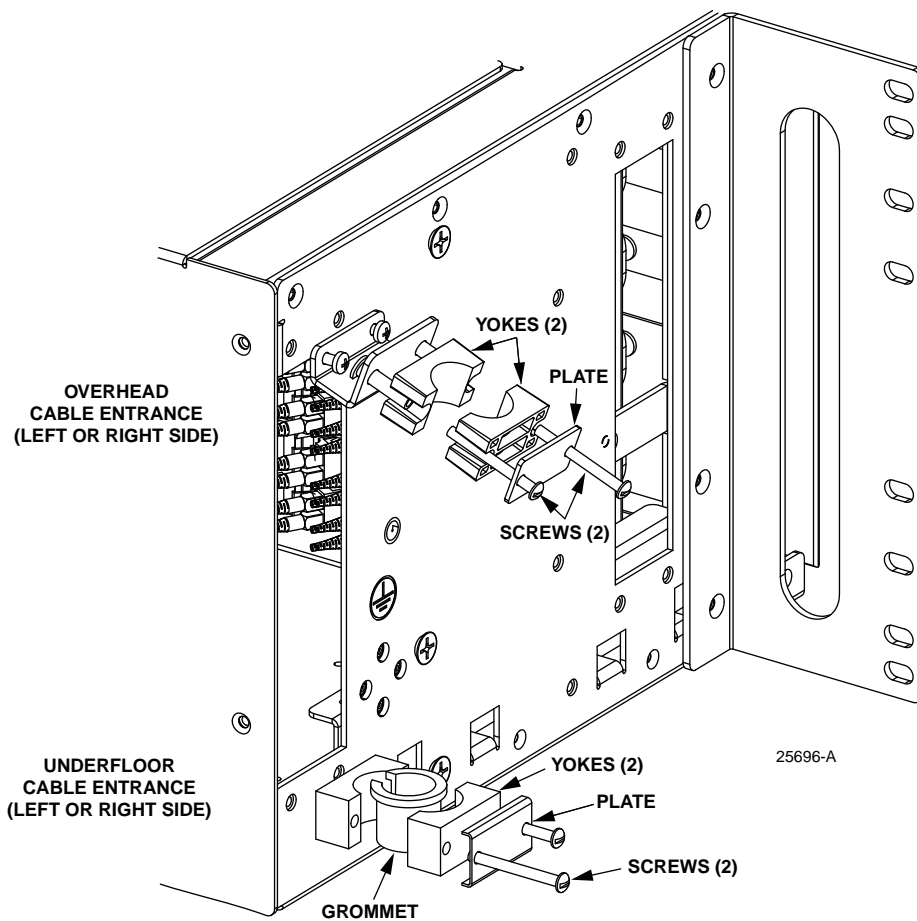

Figure 16. Cable Clamp Assembly

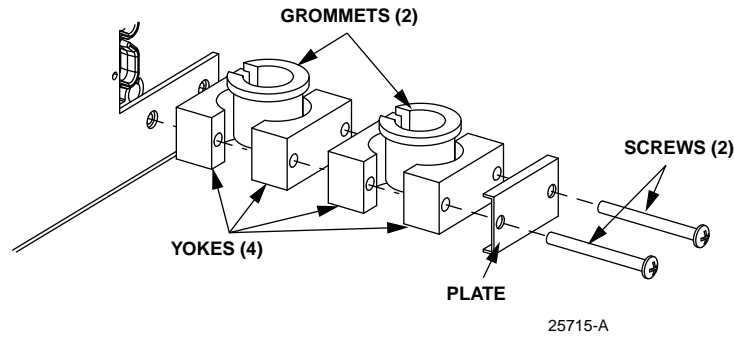

Figure 17. Stacked Cable Clamps

### 3.6 Preparing and Connecting a Pre-Connectorized Cable Assembly

This section tells how to how to prepare and connect a pre-connectorized cable assembly. The cable being installed must conform to the breakout dimensions provided.

Use the following procedure.

1. If the cable is being connectorized, assure it conforms to the breakout shown in [Figure 18](#), [Figure 19](#), or [Figure 20](#) for the cable type identified. For 'L' dimensions, refer to [Table 2](#).

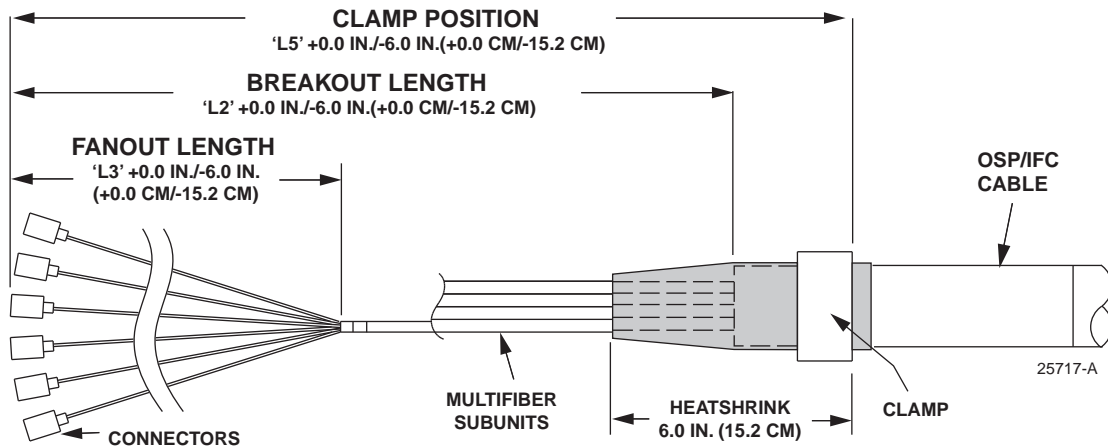

Figure 18. IFC Stranded Cable Breakout Dimensions

Table 2. Breakout Dimensions

CABLE TYPE	FIGURE		L2	L3	L4	L5
IFC Stranded	<a href="#">Figure 18</a>	3RU	63.0 in (160.0 cm)	37.0 in (93.1 cm)	N/A	67.75 in (172.1 cm)
	<a href="#">Figure 18</a>	4RU	64.5 in (163.8 cm)	37.0 in (93.1 cm)	N/A	69.25 in (175.1 cm)
	<a href="#">Figure 18</a>	5RU	65.5 in (166.4 cm)	37.0 in (93.1 cm)	N/A	70.25 in (178.4 cm)

Table 2. Breakout Dimensions, continued

CABLE TYPE	FIGURE		L2	L3	L4	L5
IFC Ribbon	Figure 19	3RU	64.8 in (164.6 cm)	38.5 in (97.8 cm)	24.5 in (62.2 cm)	70.0 in (177.8 cm)
	Figure 19	4RU	65.8 in (167,1 cm)	38.5 in (97.8 cm)	25.5 in (64.7 cm)	71.0 in (180.3 cm)
	Figure 19	5RU	66.8 in (169.7 cm)	38.5 in (97.8 cm)	26.5 in (67.3 cm)	72.0 in (182.9 cm)
OSP Cable (Stranded or Ribbon)	Figure 20	3RU	64.6 in (164.1 cm)	38.5 in (97.8 cm)	25.3 in (64.3 cm)	68.0 in (172.7 cm)
	Figure 20	4RU	65.6 in (166.6 cm)	38.5 in (97.8 cm)	26.3 in (66.8 cm)	69.0 in (175.3 cm)
	Figure 20	5RU	66.6 in (169.2 cm)	38.5 in (97.8 cm)	27.3 in (69.3 cm)	70.0 in (177.8 cm)

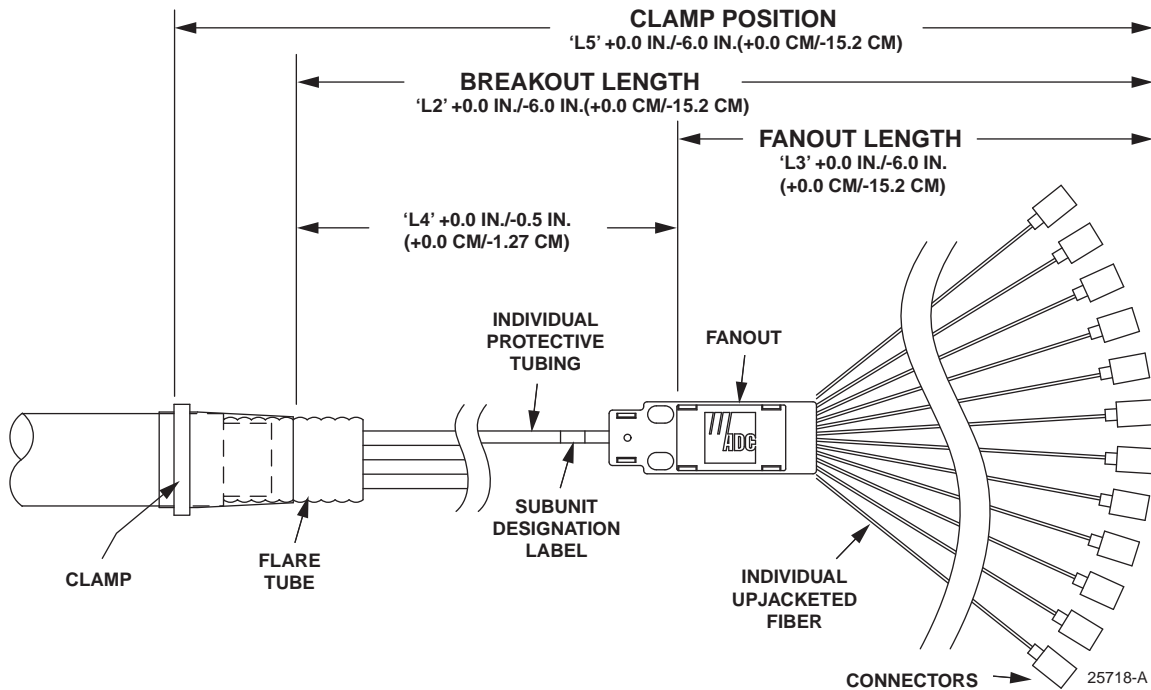

Figure 19. IFC Ribbon Breakout Dimensions

- Determine the correct clamp and grommet combination required to secure the cable to the panel. For details on the cable clamp itself, refer to [Section 3.5 on Page 16](#).
- Determine the cable entry location. Cables may enter the panel from either top or bottom and may be clamped to either the left or right side, top or bottom, as shown in [Figure 21](#), [Figure 22](#), [Figure 23](#), and [Figure 24](#). Use the integral fanning tree to arrange the fibers so that they are across from the adapter where they are being terminated.



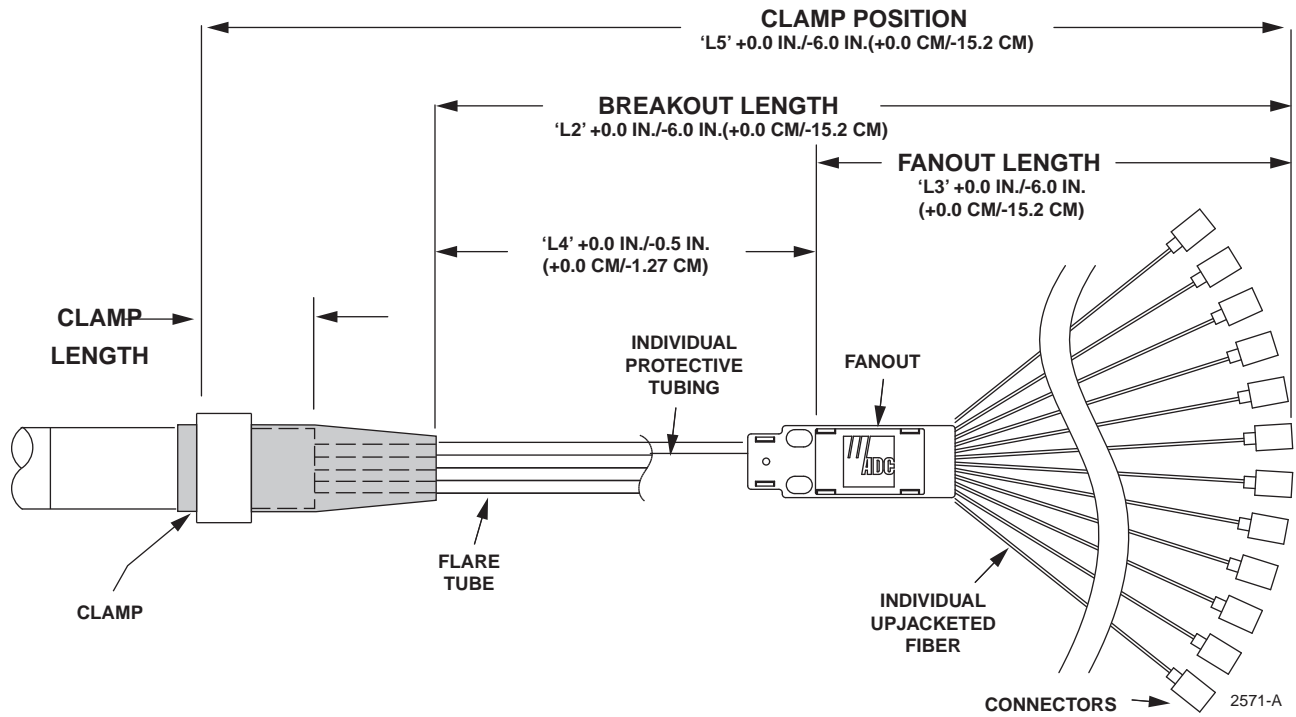

Figure 20. OSP Cable Breakout Dimensions

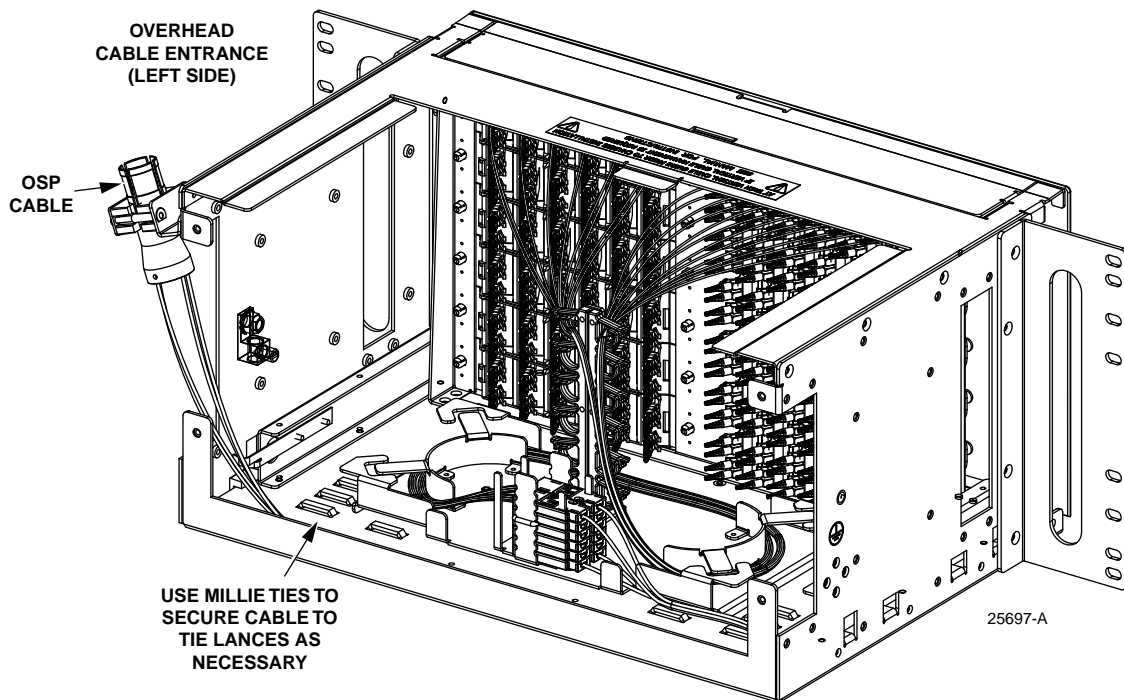

Figure 21. Overhead, Left Side Terminated Cable Entrance (5RU Panel Rear View)

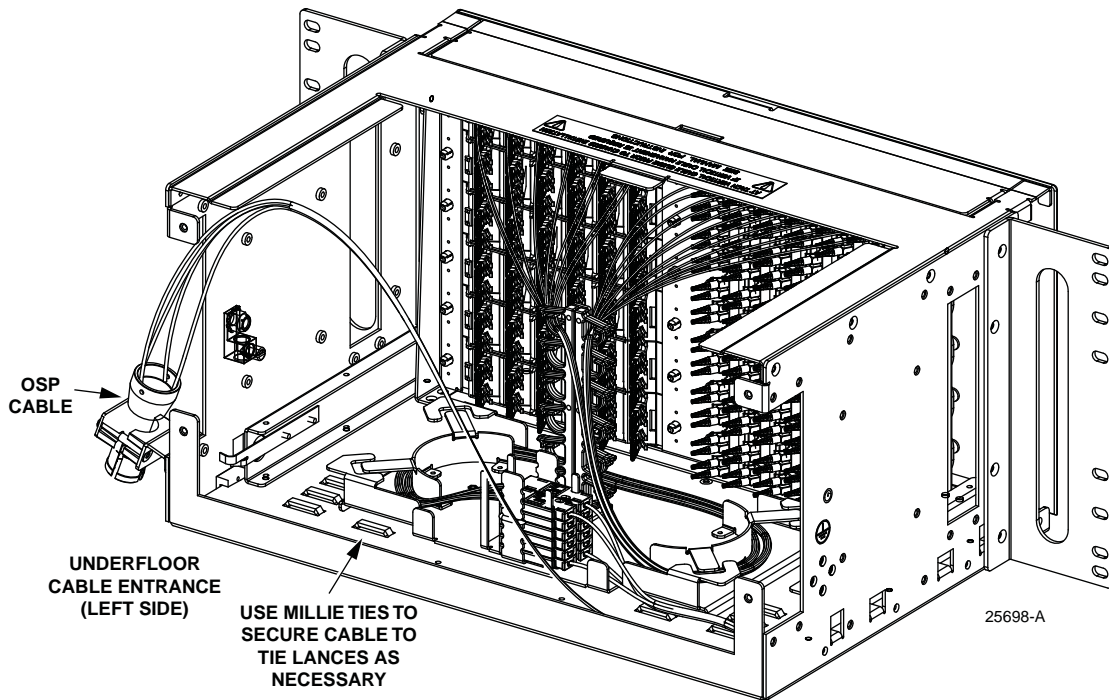

Figure 22. Underfloor, Left Side Terminated Cable Entrance (5RU Panel Rear View)

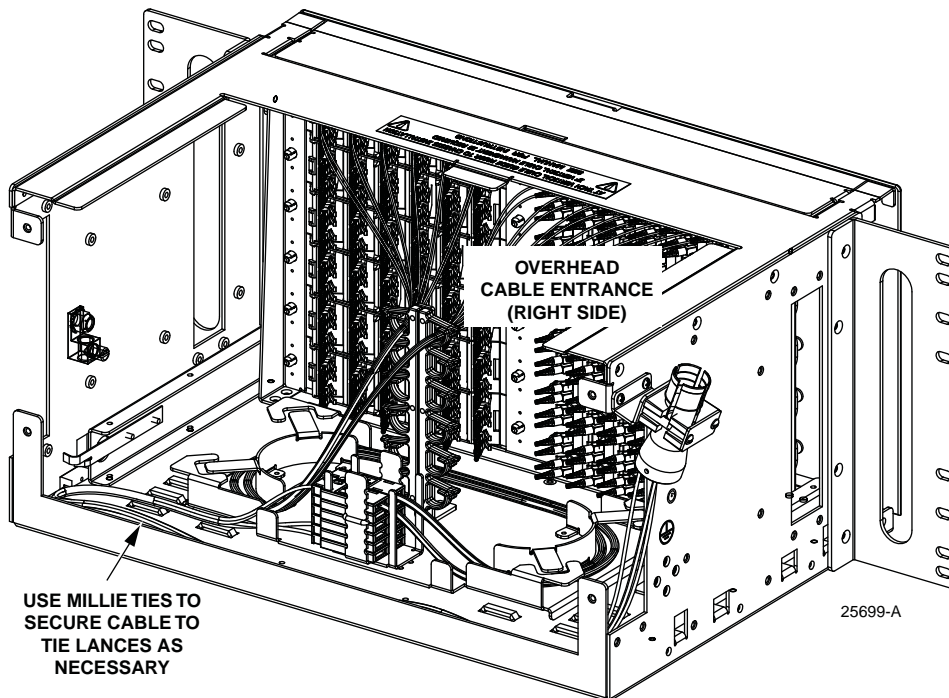

Figure 23. Overhead, Right Side Terminated Cable Entrance (5RU Panel Rear View)

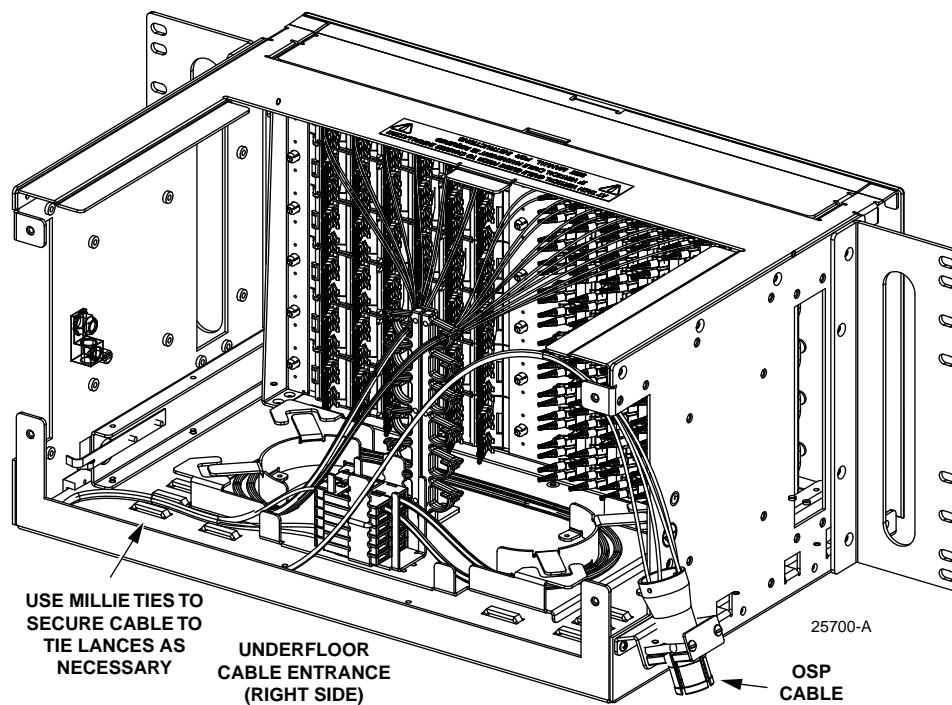

Figure 24. Underfloor, Right Side Terminated Cable Entrance (5RU Panel Rear View)

### 3.7 Installing Pigtail Adapter Pack Assemblies and Splice Trays

This section describes how to install pigtail adapter pack assemblies and splice trays in an empty panel or as an addition in a termination/splice panel where some of the adapter pack positions were left vacant at installation. Either stranded or ribbon pigtails may be installed. The 3RU panel accepts up to six adapter packs pigtail assemblies. The 4RU panel accepts up to eight assemblies. The 5RU panel accepts up to 12 assemblies. Use the following procedure.

1. Install the pigtail adapter packs from the front side of the panel as described in [Section 3.2 on Page 9](#), threading through the pigtails to the rear side of the adapter bulkhead.

► **Note:** As a rule of thumb, begin with the lowest number positions in the adapter bulkhead (top right of bulkhead when viewed from the back of the panel) and route to the lowest splice tray in the stack; however, when splicing ribbon adapter packs, not all of the splice trays will be required and the lowest splice tray can be used for slack, if desired. Pigtails from the right side of the adapter bulkhead should be routed around to the left in a counterclockwise direction (as shown in [Figure 25](#)), pigtails from the left side of the adapter bulkhead should be routed around to the right in a clockwise direction ([Figure 26](#)).

2. Route the pigtails within the panel, as shown. The routing is the same for stranded and ribbon except within the fanout holder, where there will be either a fanout chip for ribbon pigtail assemblies or a lacing tie down for stranded fibers.

► **Note:** Route the 900 micron section of the pigtails around the inside radius until taken up fully then route the jacketed section two times around the outer radius limiters and into the splice tray as shown in [Figure 25](#) and [Figure 26](#).

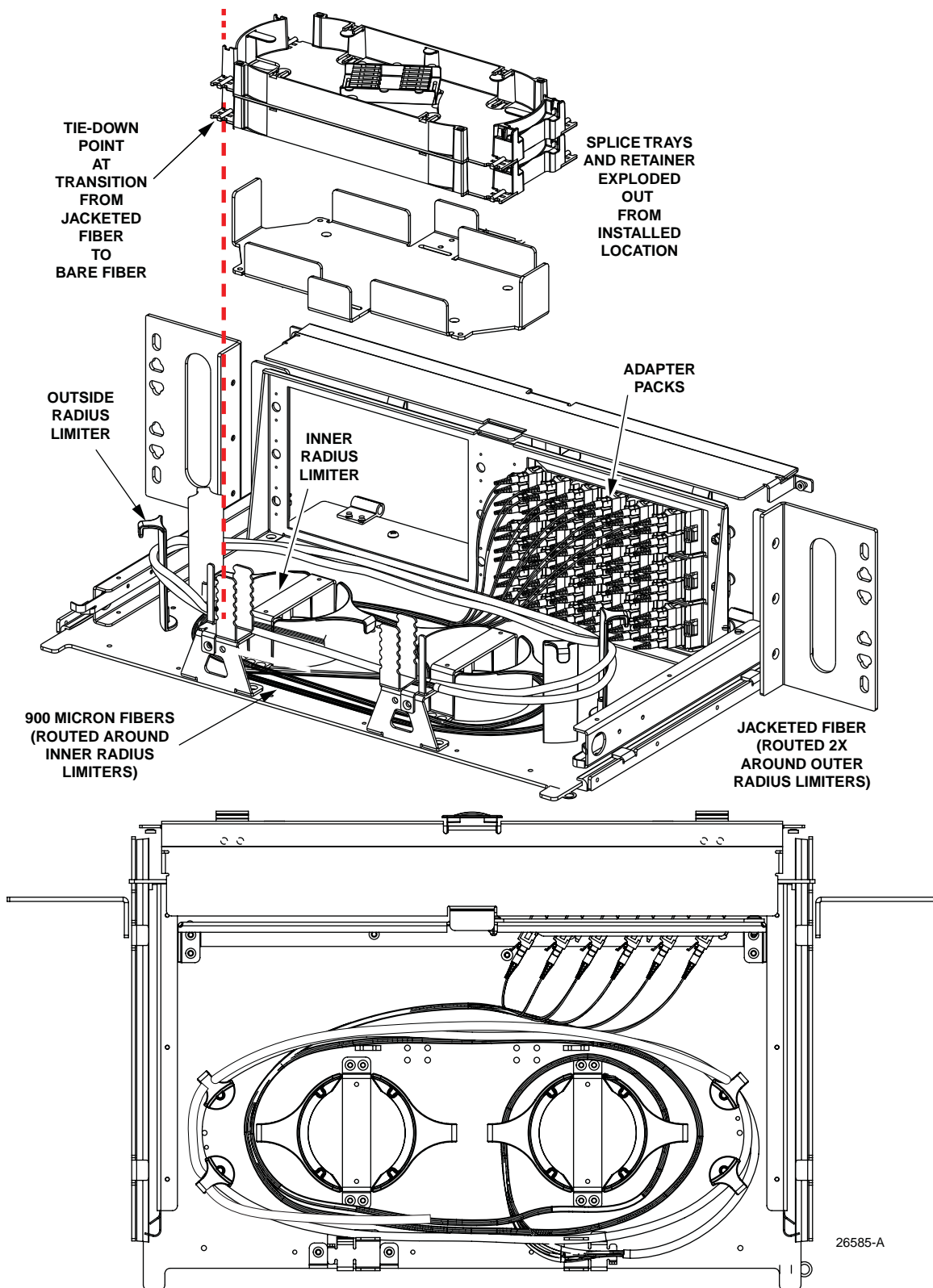
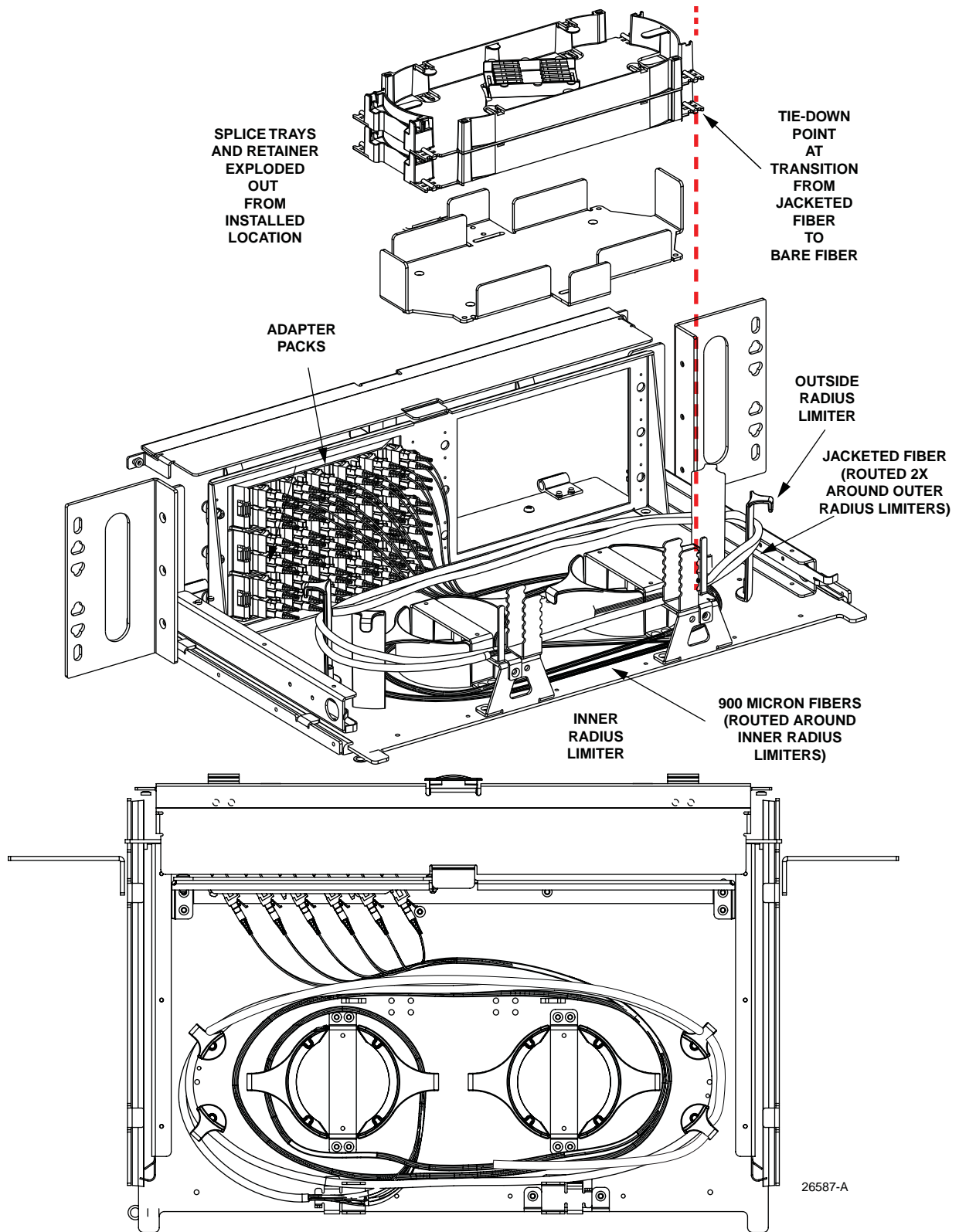

Figure 25. Routing Pigtails from Adapter Packs to Splice Trays (Right Side in Rear View)



26587-A

Figure 26. Routing Pigtailed from Adapter Packs to Splice Trays (Left Side in Rear View)



3. As the pigtail adapter packs are installed, route the fibers within the splice trays. The stranded fibers fill in 48 to a splice tray, The ribbon pigtails fill in 96 fibers per splice tray.

▶ **Note:** Pigtails wound in a clockwise direction should enter the splice tray at the bottom right as shown in [Figure 27](#) for stranded pigtails and [Figure 28](#) for ribbon pigtails. Pigtails wound in a counterclockwise direction should enter the splice tray on bottom left (mirror image of routing shown in figures).

▶ **Note:** When mass fusion splice chips are used, bottom splice tray can be used for slack.

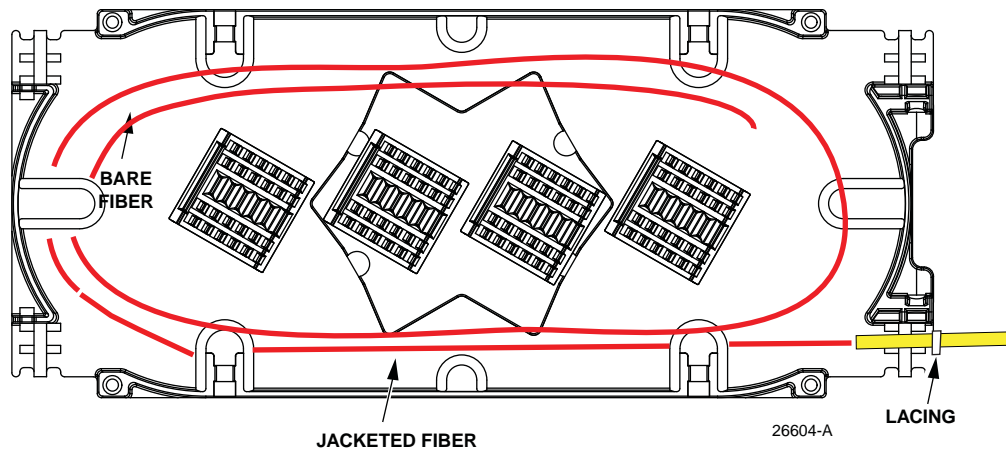

Figure 27. Stranded Pigtails Splice Tray Cable Routing (for pigtails routed clockwise)

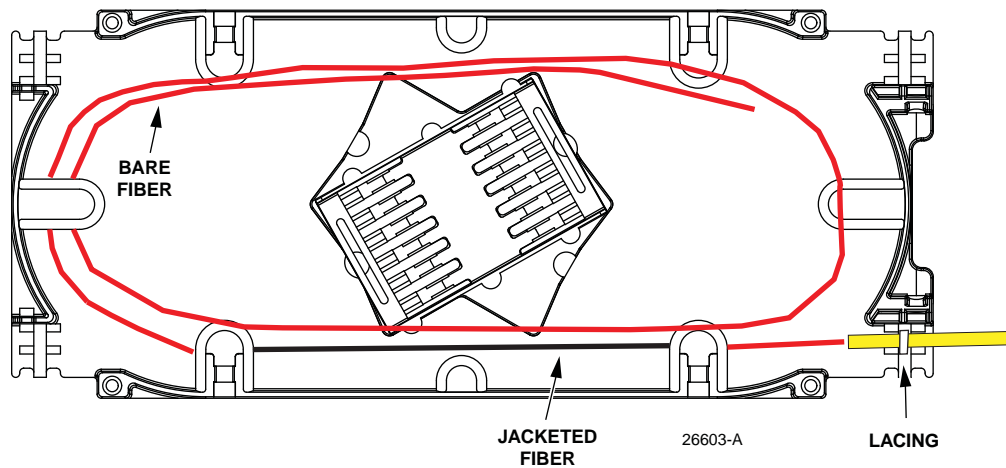

Figure 28. Ribbon Pigtails Splice Tray Cable Routing (for pigtails (for pigtails routed clockwise))

4. Stack up the splice trays as shown in [Figure 29](#) and secure the splice tray slack with the Velcro strip provided (not shown in figure).

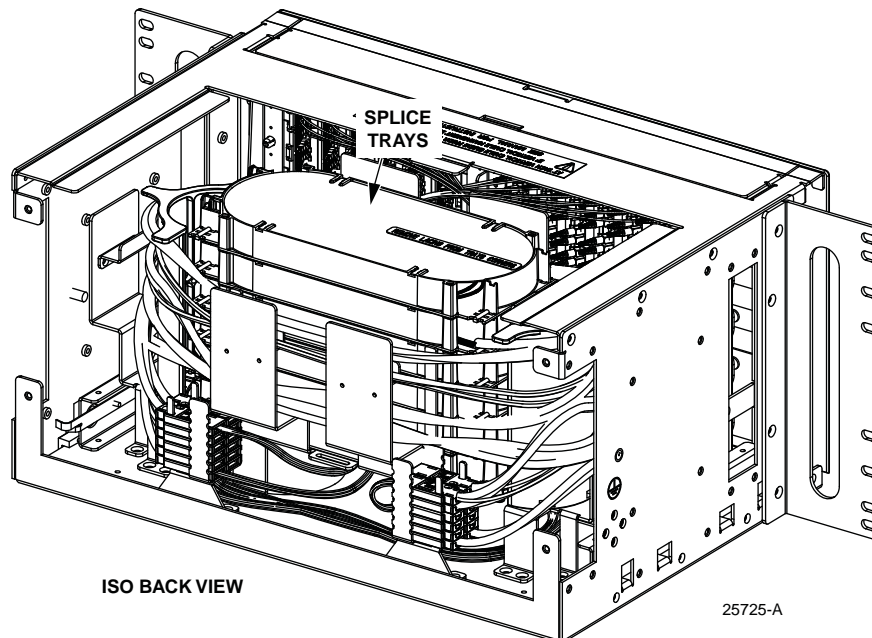

Figure 29. Stacked Splice Trays in 5RU Panel

### 3.8 Routing an IFC/OSP Cable

Allow a fiber service loop of at least 126-inches (3.5 meters) when stripping the cable sheath. This provides sufficient length for routing the buffer tubes within the panel and for splicing. After entry, the buffer tubes are routed to the splice tray. Use the following procedure.

1. Route the IFC/OSP cable to the selected entry opening at the side of the panel.

► **Note:** Cables may enter the panel from either the top or bottom and may be clamped to either the left or right side. [Figure 31](#) and [Figure 32](#) show cable clamp position and cable routing to splice tray for top left side entry. [Figure 33](#) and [Figure 34](#) show top right entry. Bottom entries are the same except cable clamp location is the same as shown in [Figure 13 on Page 14](#) and [Figure 15 on Page 15](#).

2. Strip back OSP cable buffer tube approximately 66-inches (167.64 cm) to expose optical fibers. Follow cable manufacturer's recommendations when stripping the sheath.
3. Break out the OSP cable corresponding to the dimensions given in [Figure 30](#). Follow cable manufacturer's recommendations when stripping the sheath.

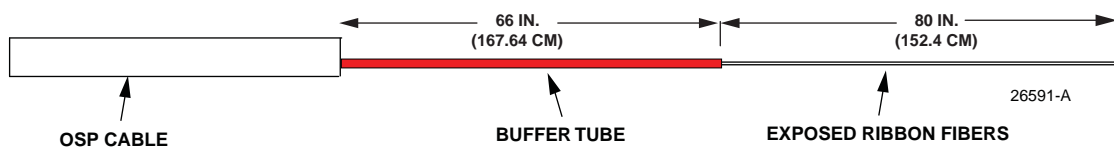

Figure 30. OSP Cable Breakout Dimensions



4. Determine the correct clamp and grommet combination required to secure the cable to the panel. For details on the cable clamp itself, refer to [Section 3.5 on Page 16](#).
5. If splicing is to be completed later coil the buffer tubes around the radius limiters on the bottom of the panel and close rear cover. If splicing at the present time, follow local practice to complete the splices. Route the IFC/OSP fibers within the splice tray as shown in [Figure 35](#) for stranded fiber and [Figure 36](#) for ribbon fiber.

► **Note:** All subunits should enter the splice tray on the same side as the pigtails already present in the same splice tray.

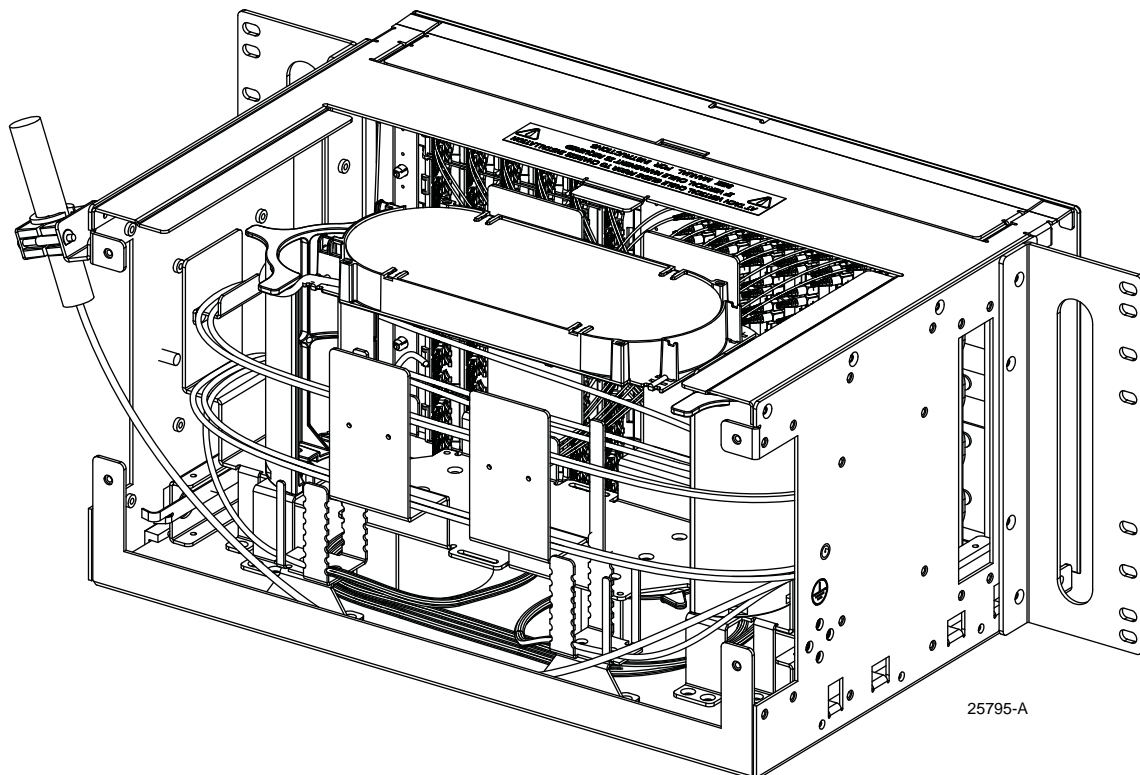

Figure 31. Left Side Cable Entrance, Routing to Splice Tray. Iso View



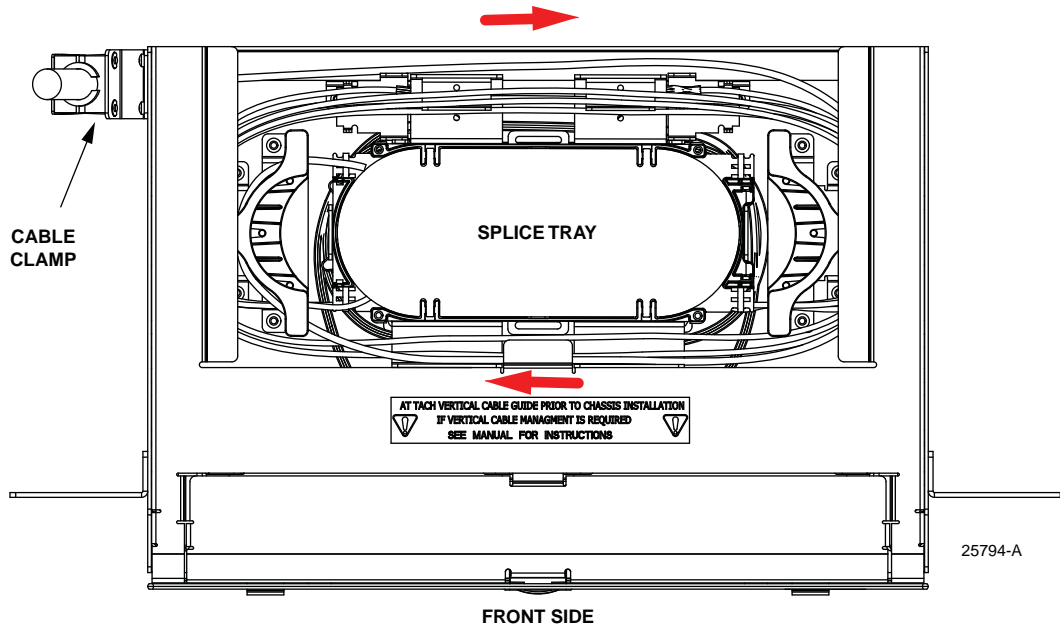

Figure 34. Left Side Cable Entrance, Routing to Splice Tray, iso Back View

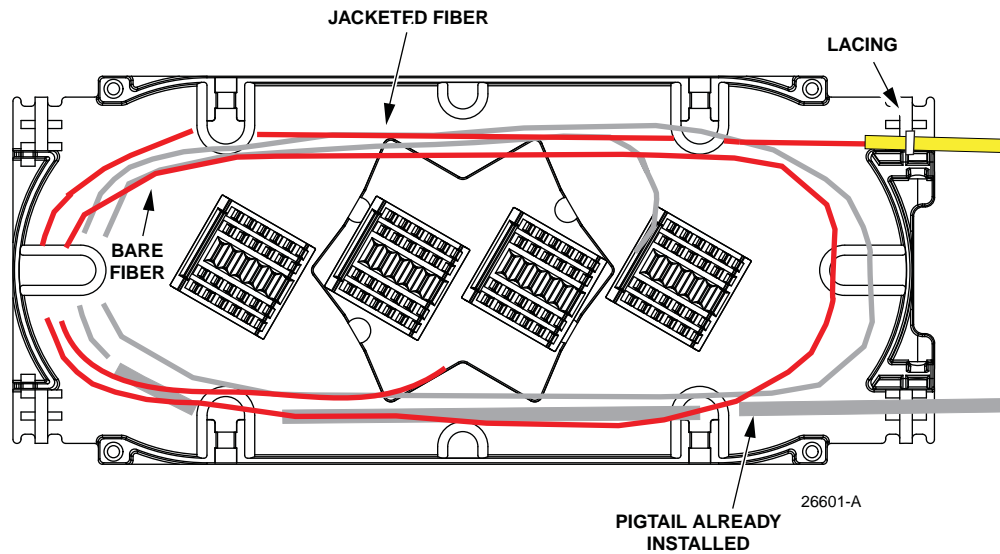

Figure 35. Stranded IFC/OSP Fiber Splice Tray Routing

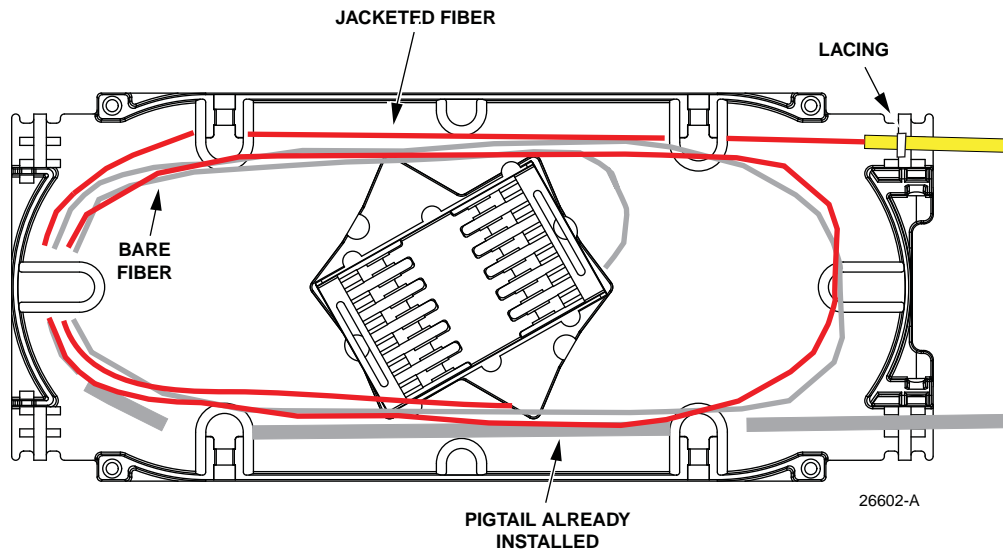

Figure 36. Ribbon IFC/OSP Fiber Splice Tray Routing

### 3.9 Performing a Ribbon Fiber Heat Fusion Splice

- **Note:** In this procedure, the splice trays and splice chips are assumed to have been loaded as described in the previous sections of these installation instructions.

Use the following procedure to perform a splice.

1. Unwind the splice tray from the panel and set it on an adjacent flat surface.
2. Remove the splice tray cover.
3. Unwind the splice chip from the splice tray to the full extent of the fibers, and set the splice chip on an adjacent flat surface.
4. Ensure that the bare fiber lengths of the distribution and feeder fibers are as shown in [Figure 37](#) (distribution fiber on top) or [Figure 38](#) (feeder fiber on top). Note that the lengths are different for the distribution and feeder fibers.
5. Perform the splice per local guidelines.
6. For the configuration being used, wind the splice chip back into the splice tray as shown in [Figure 37](#) or [Figure 38](#).
7. Replace the splice tray cover.
8. If there is an additional splice tray with a splice to be performed, set the first splice tray to the side and repeat the above steps for the additional splice tray.
9. When done with all splice trays, wind the splice trays back into the panel so that they wind up stacked in the same order as at the beginning of this procedure.

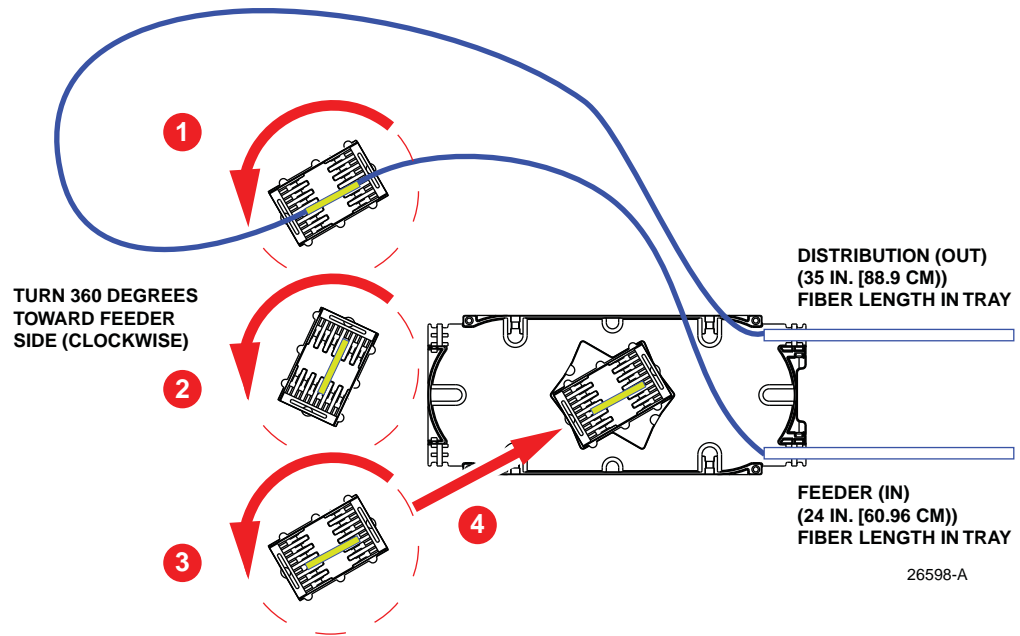

Figure 37. Winding the Splice Chip Back Into Tray (Distribution Fiber on Top, Feeder Fiber on Bottom)

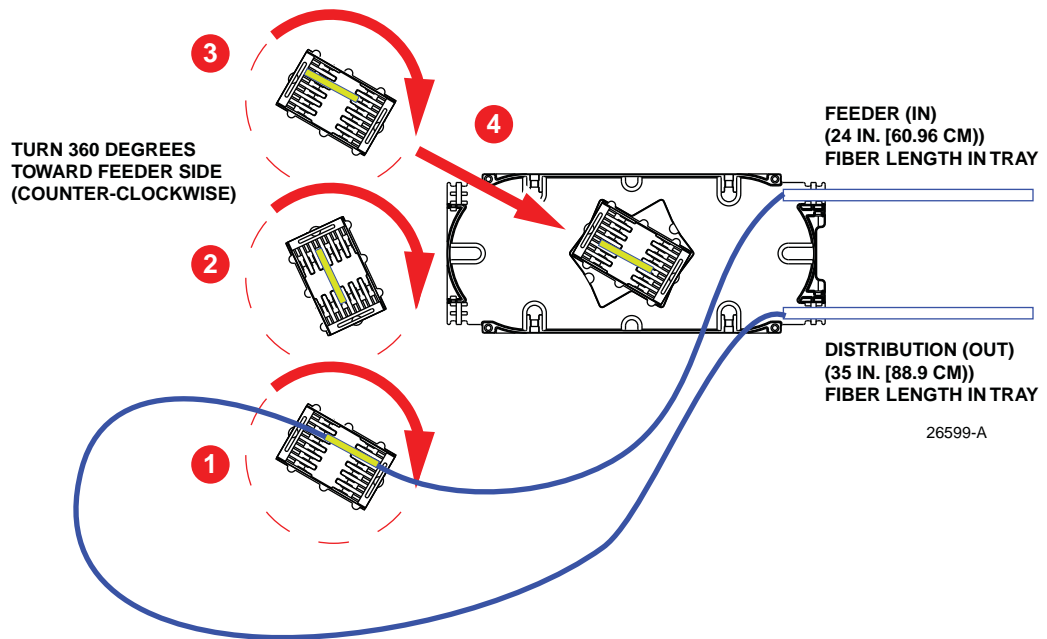

Figure 38. Winding the Splice Chip Back Into Tray (Feeder Fiber on Top, Distribution Fiber on Bottom)

10. Figure 39 shows a completed splice tray with a ribbon fiber heat fusion splice.

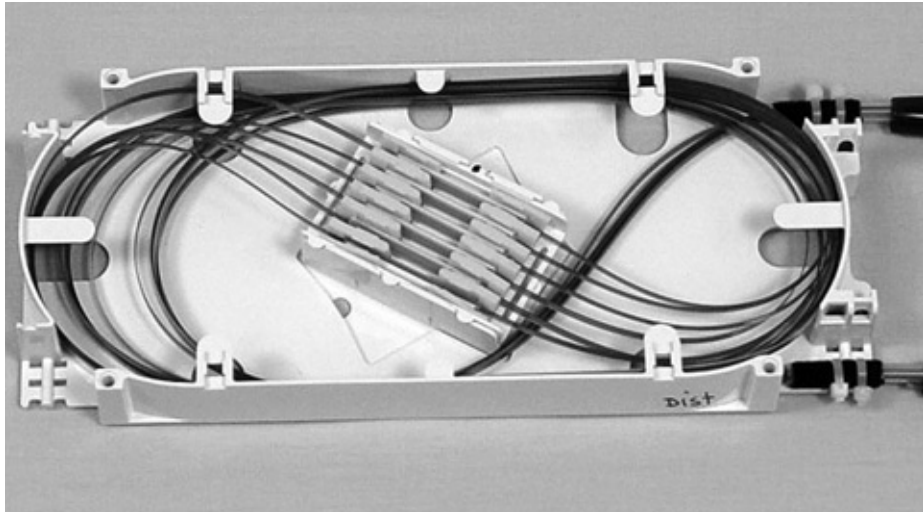

Figure 39. Example of Completed Splice

## 4 OPERATION

### 4.1 Accessing Inner Panel

To access the inner panel, use the following procedure.

1. From the front of the panel, pull down the front door latch and swing down the front door as shown in [Figure 40](#). Open the door until it is flat with the bottom of the panel.

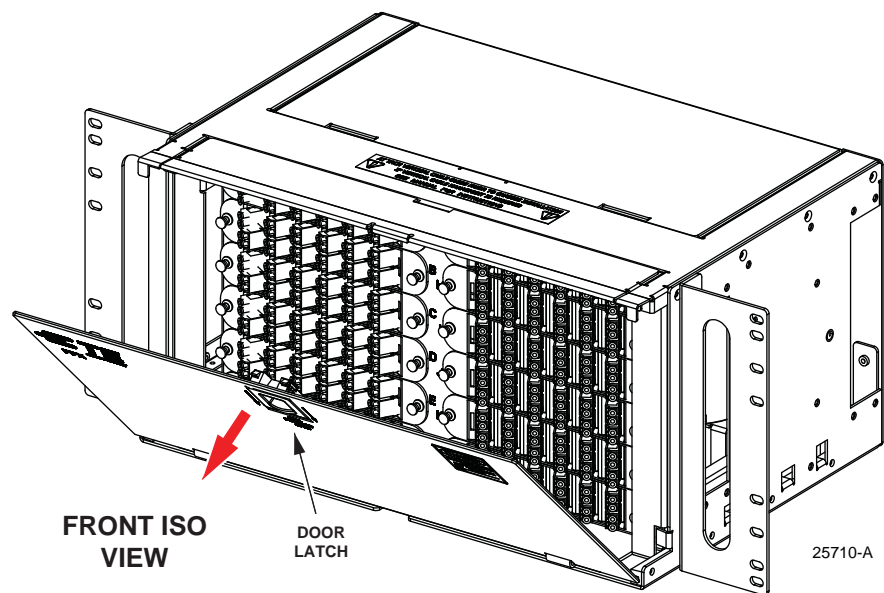

Figure 40. Opening the Front Door (5RU Panel Shown)

2. Push down the red release tab and slide out the drawer as shown in [Figure 41](#).

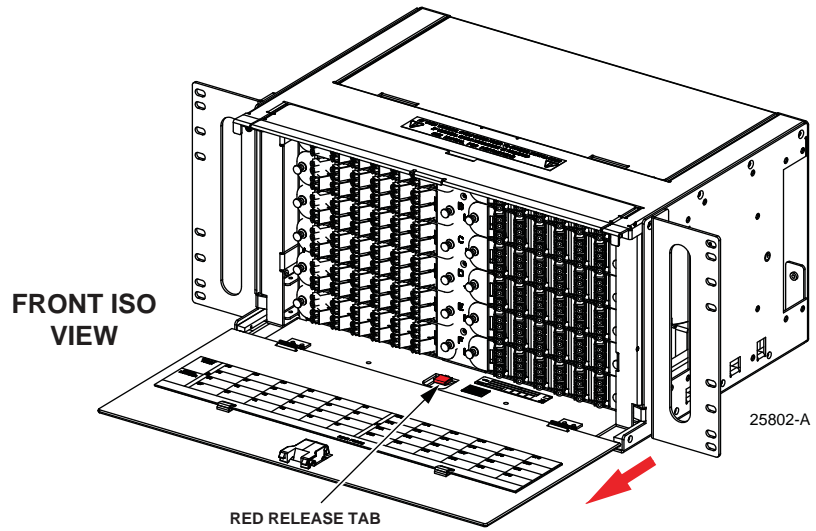

Figure 41. Sliding the Drawer Forward

3. Slide drawer out to full extension as shown in [Figure 42](#).

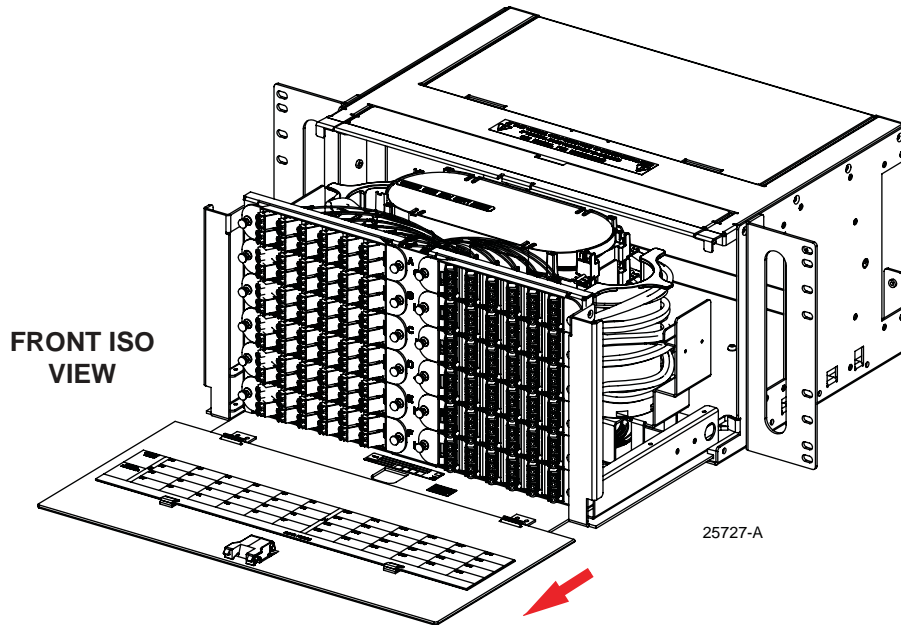

Figure 42. Sliding the Drawer Forward



## 4.2 Removing Fanout Holders to Gain Access to Splice Trays

If the top cover of the panel cannot be removed, removing the fan out holders will allow the splice trays to be lifted straight out to the back (rather than in an upward direction).

Remove the fanout holders referring to [Figure 43](#) or [Figure 44](#).

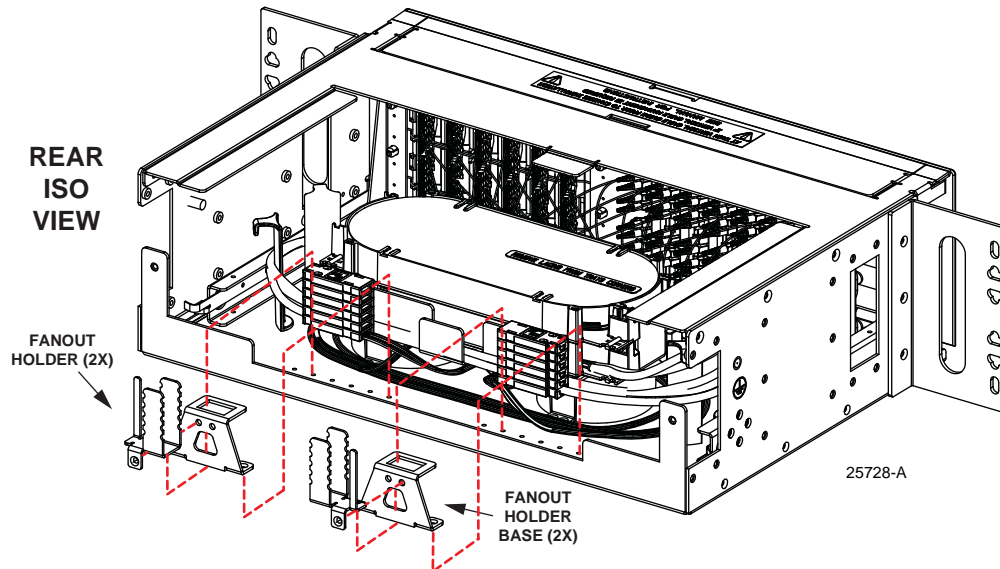

Figure 43. Removing Fanout Holders (3RU and 4RU Panel)

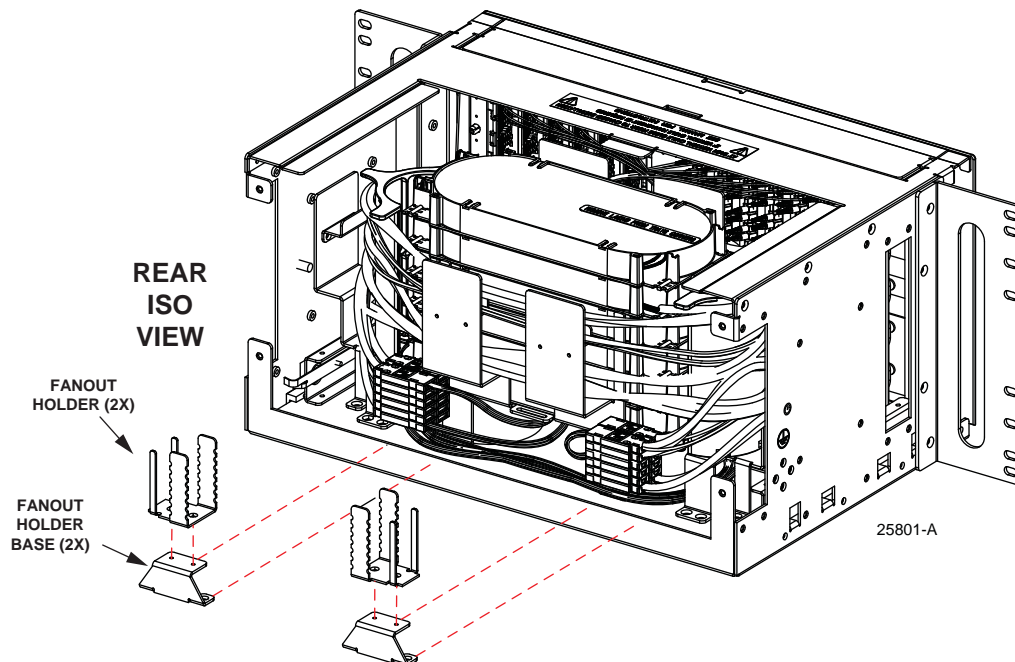

Figure 44. Removing Fanout Holders (5RU Panel)

## 5 CUSTOMER INFORMATION AND ASSISTANCE

- To find out more about CommScope® products, visit us on the web at [www.commscope.com](http://www.commscope.com)
- For technical assistance, customer service, or to report any missing/damaged parts, visit us at <http://www.commscope.com/SupportCenter>

