

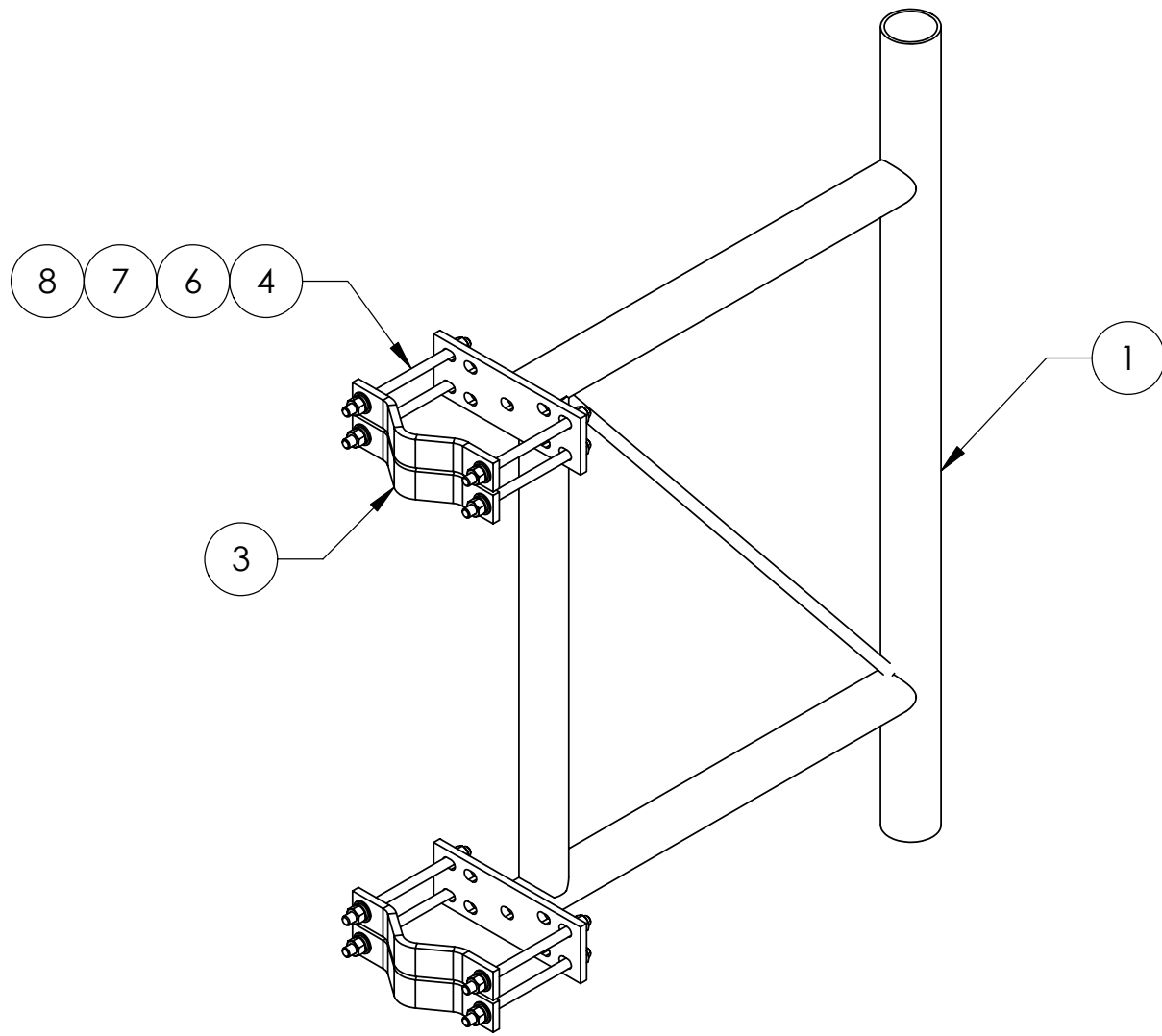

ITEM	PART NO.	DESCRIPTION	QTY.	WEIGHT
1	PBG3S	36" HEAVY DUTY STAND-OFF	1	98.83 LBS
2	PBG3S2H	HARDWARE KIT (ITEMS 3-5)	1	
3	MCP10	MEDIUM CLAMP HALF	4	3.36 LBS
4	MT-381-10	5/8" X 10" THREADED ROD	8	0.79 LBS
5	HB5816	HARDWARE KIT (ITEMS 6-8)	1	
6	GN05A	5/8" GALV HEX NUT (A325)	16	0.08 LBS
7	GWL-05	5/8" GALV LOCK WASHER	16	0.01 LBS
8	GWF05A	5/8" GALV FLAT WASHER (A325)	16	0.03 LBS

REVISIONS				
REV.	ZONE	DESCRIPTION	BY	DATE
A		INITIAL RELEASE	MFS	04/01/01
B		CHANGED PART # FOR ITEM 1	LAP	04/09/01
C		CHANGED DESCRIPTION FOR ITEM 2	LAP	04/27/01
D		UPDATE HARDWARE KIT P/N	ACG	08/16/06

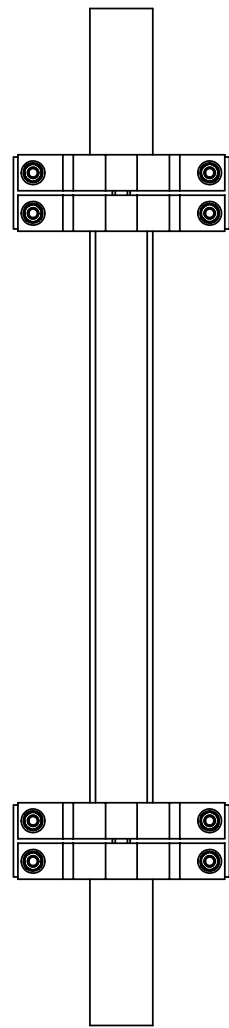
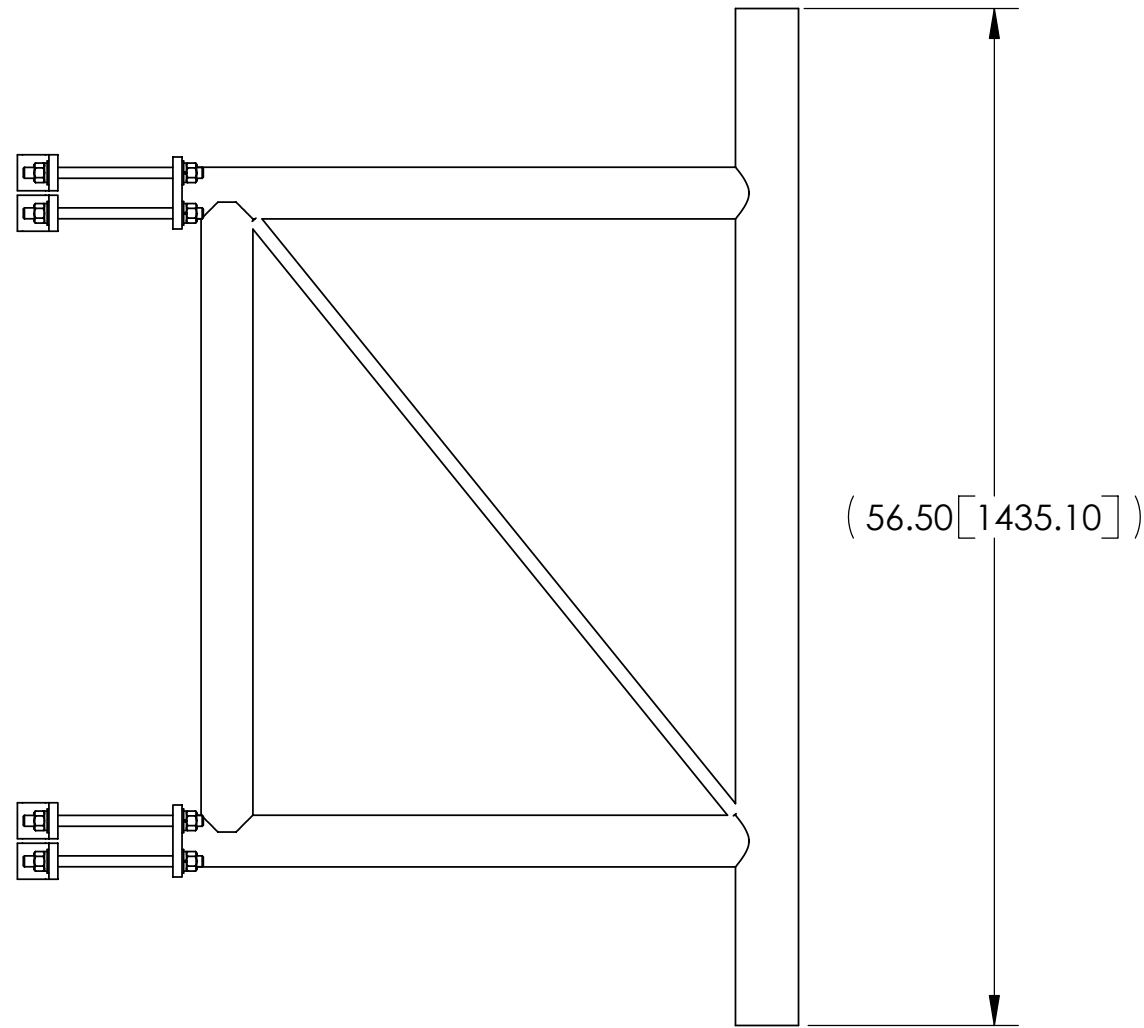
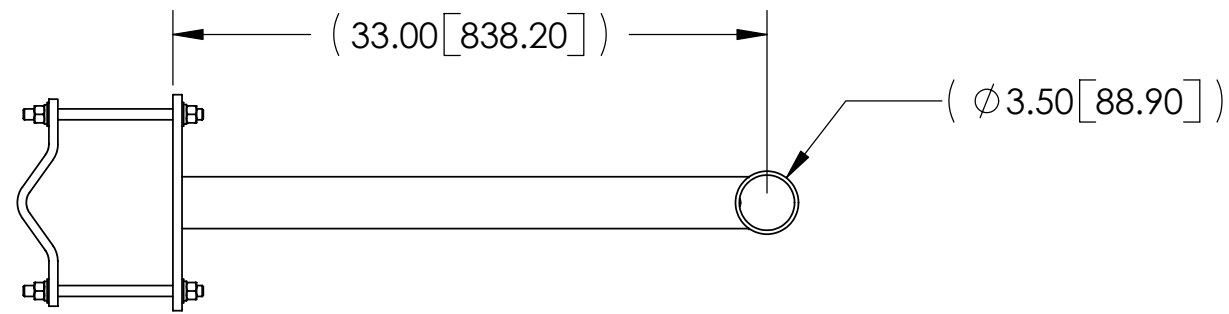

NOTES:
 1. ALL METRIC DIMENSIONS ARE IN BRACKETS.
 2. FOR Ø4" TO Ø8" O.D. TOWER LEG

<small>These drawings and specifications are the proprietary property of ANDREW CORPORATION and may be used only for the specific purpose authorized in writing by Andrew Corporation.</small> ALL DIMENSIONS ARE IN INCHES U.O.S. TOLERANCES UNLESS OTHERWISE SPECIFIED: .X = ± .06 ANGLES ±2° .XX = ± .03 FRACTIONS ±1/32 .XXX = ± .010 REMOVE BURRS AND BREAK EDGES .005 DO NOT SCALE THIS PRINT	DRAWN BY: ACG	SHEET: 1 of 1	PART NUMBER: PB-G3S-4
	CHECKED BY: TP	SCALE: NTS	DESCRIPTION: 36" HEAVY DUTY STAND-OFF
	DATE: 10/03/05	MATERIAL: A36, A53	DRAWING TYPE: ASSEMBLY DRAWING
	REVISION: D	FINISH: GALV A123	
	WEIGHT: 120.82 LBS	ORLAND PARK, IL. 60462 U.S.A.	