

NOTES:

1.0 ALL METRIC DIMENSIONS ARE IN BRACKETS.

REVISIONS				
REV.	ECN	DESCRIPTION	BY	DATE
A	8000028694	INITIAL RELEASE	MRC	03/01/18

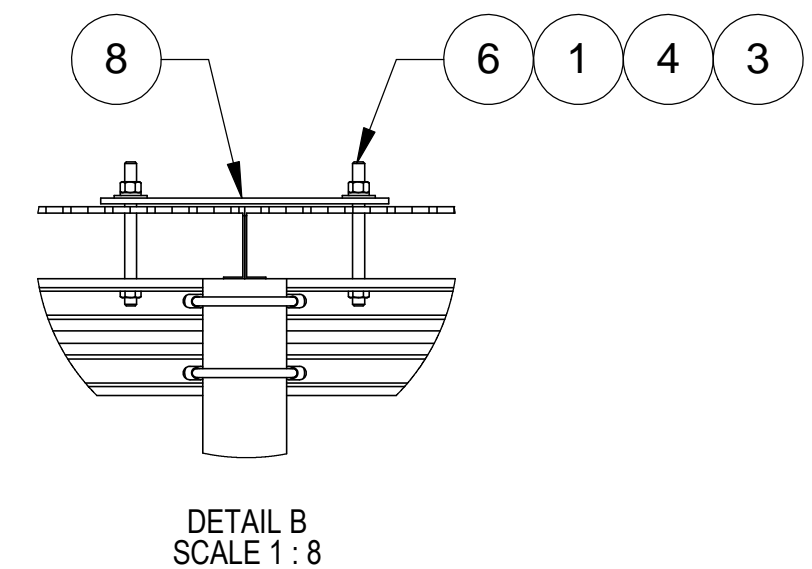
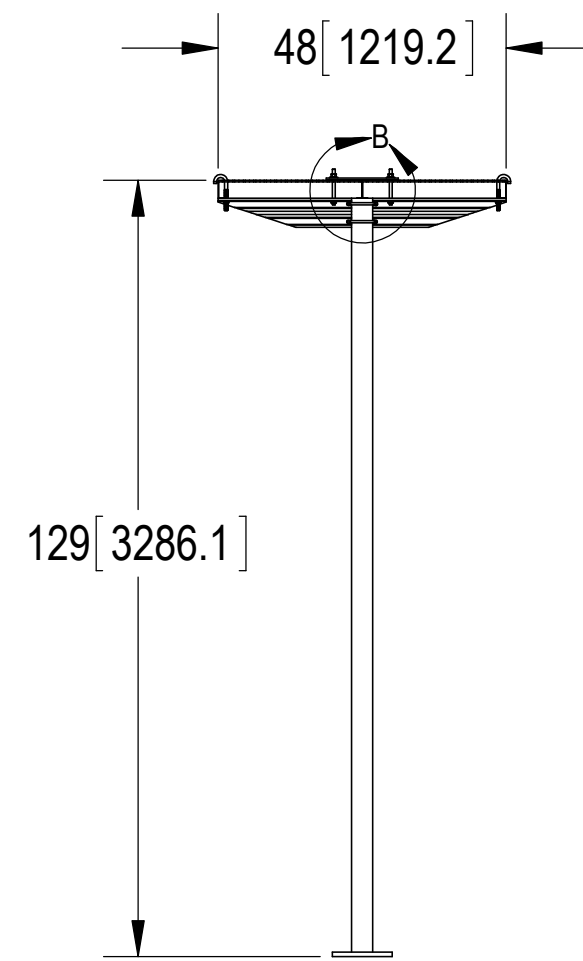
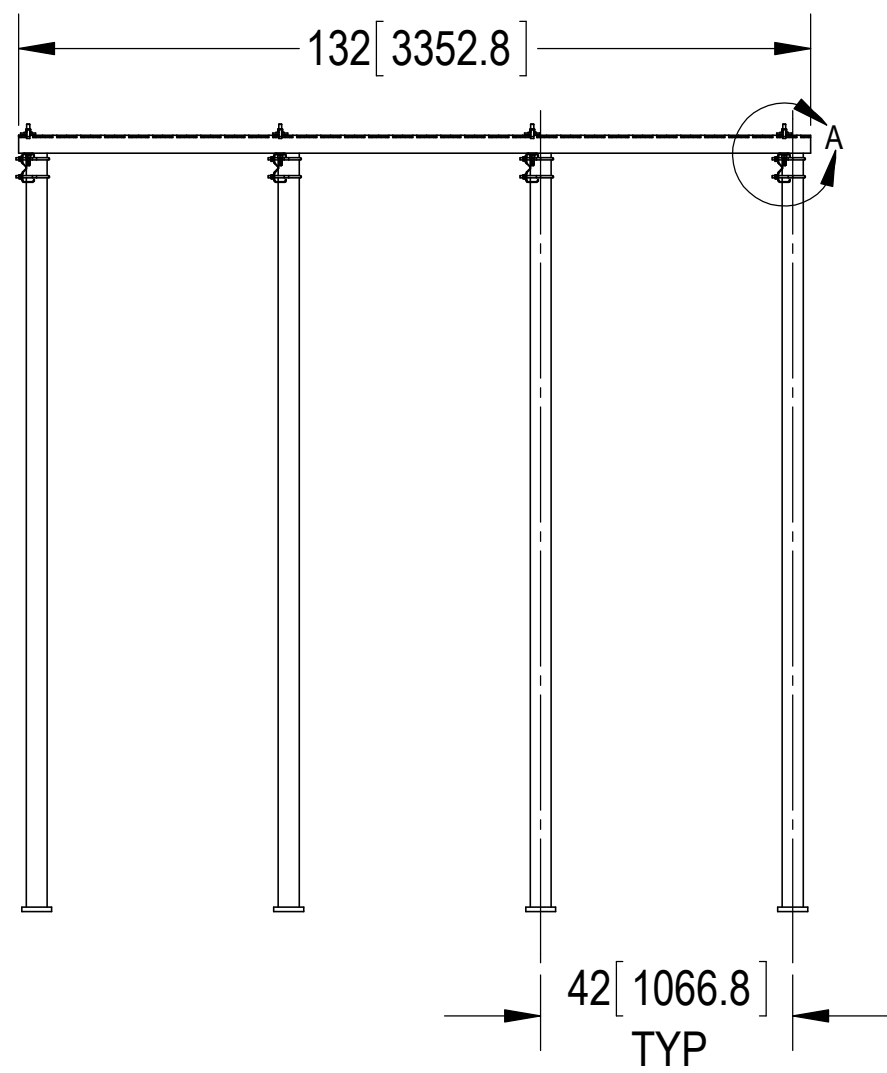
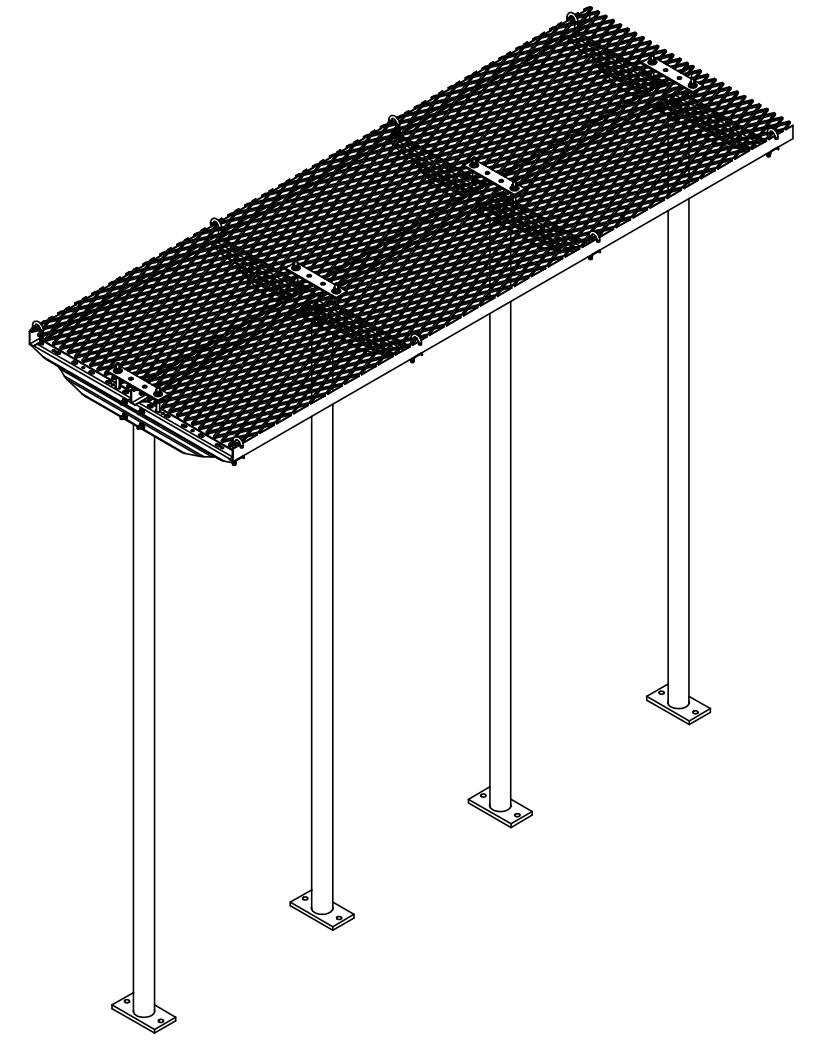
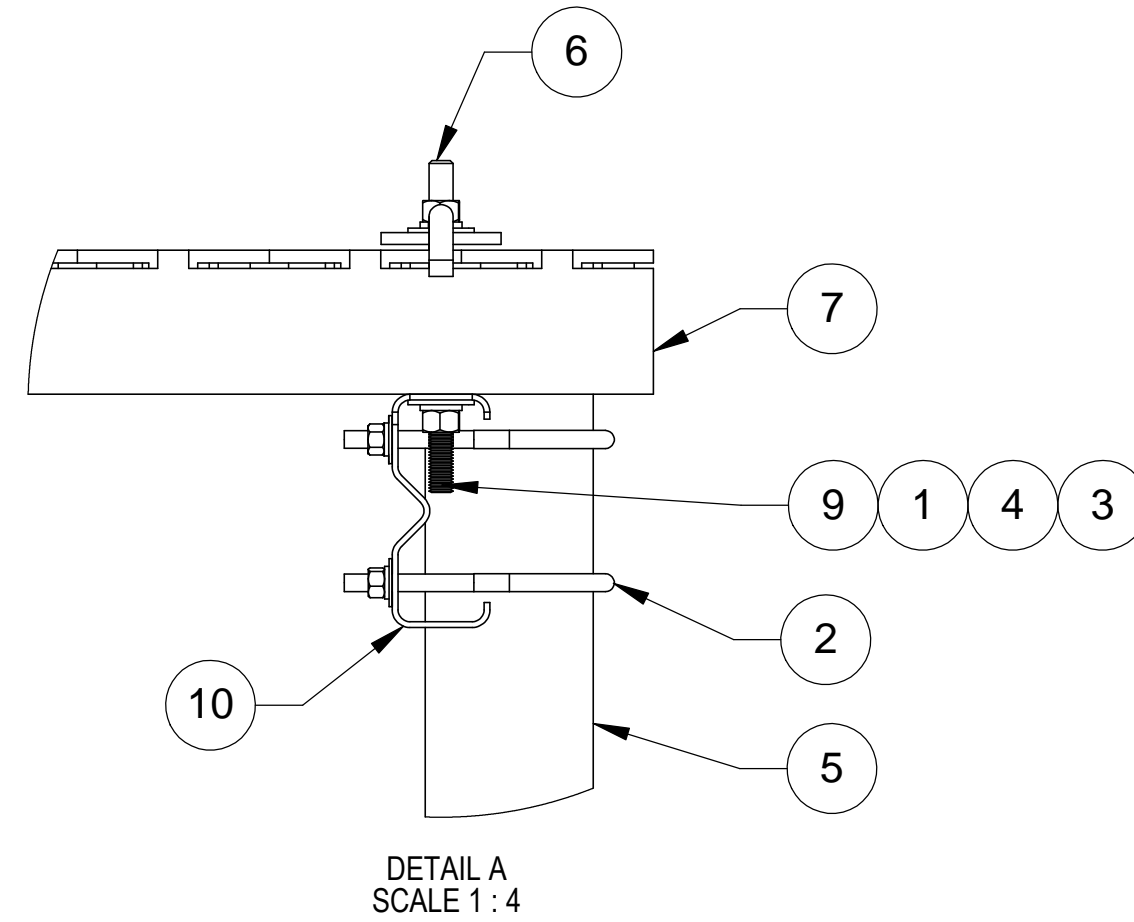
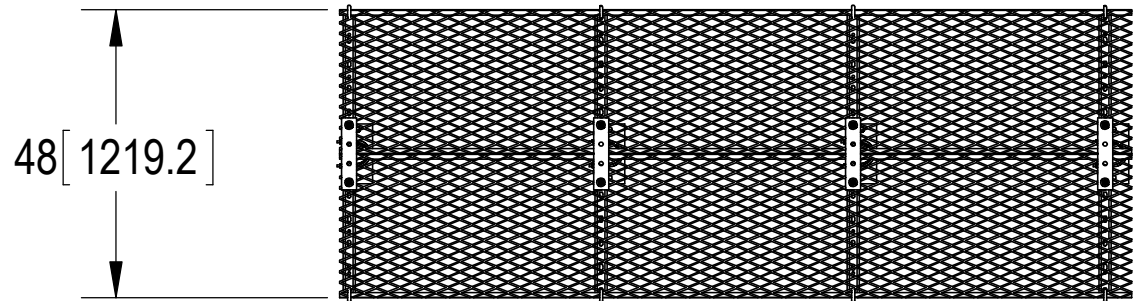

ITEM	PART NO.	DESCRIPTION	QTY.	WEIGHT	NOTE NO.
1	GN-04	1/2" GALV HEX NUT	24	0.04 LBS	
2	GUB-3355	3/8" X 3-5/8" X 5-1/4" GALV U-BOLT	8	0.40 LBS	
3	GWF-04	1/2" GALV FLAT WASHER	24	0.03 LBS	
4	GWL-04	1/2" GALV LOCK WASHER	24	0.01 LBS	
5	MF12616510	PIPE COLUMN KIT	4	69.59 LBS	
6	MT-379-6	1/2" X 6" GALV THREADED ROD	8	0.33 LBS	
7	MTC401512	24" X 132" SAFETY GRATING	2	88.33 LBS	
8	SB4	SPLICE PLATE, 4 HOLES	4	2.01 LBS	
9	WBJB6	1/2" J-BOLT	8	0.41 LBS	
10	WBLB48301	48" WAVE GUIDE BRIDGE SUPPORT BRACKET	4	10.91 LBS	

COMMSCOPE, INC. OF NORTH CAROLINA

TOLERANCES		SAP MATERIAL MASTER	
0 PLACE X ± .25	2 PLACE .XX ± .06	<b>MTC4015132C</b>	
1 PLACE .X ± .12	ANGLES ± 2°		

FINISH		MATERIAL	
<b>GALV A123</b>		<b>A500, A1011/1018</b>	

UNLESS OTHERWISE SPECIFIED DIMENSIONS ARE IN MILLIMETERS INTERPRET PER ISO STANDARDS HANDBOOK TECHNICAL DRAWINGS VOLUMES 1 & 2, THIRD EDITION (2002)	CE	NAME	DATE	TITLE
	RW	<b>MRC</b>	11/13/17	<b>ICE CANOPY, 4 POSTS</b>
	RV			
	AD			
RE	<b>TP</b>	11/13/17	SCALE	DOCUMENT NO.
ECN	<b>8000028694</b>		<b>1:32</b>	<b>MTC4015132C</b>

DENSITY	0.28	lbs/in <sup>3</sup>
MASS	518.54	lbs
VOLUME	1834.48	in <sup>3</sup>
SURFACE AREA		in <sup>2</sup>
HEIGHT		
LENGTH		
WIDTH		

SIZE	WORK AREA	MODEL			DRAWING			SHEET
<b>C</b>		VERSION	STATUS	REVISION	VERSION	STATUS	REVISION	1 OF 2
							<b>A</b>	

4

3

2

1

NOTES:

1.0 ALL METRIC DIMENSIONS ARE IN BRACKETS.

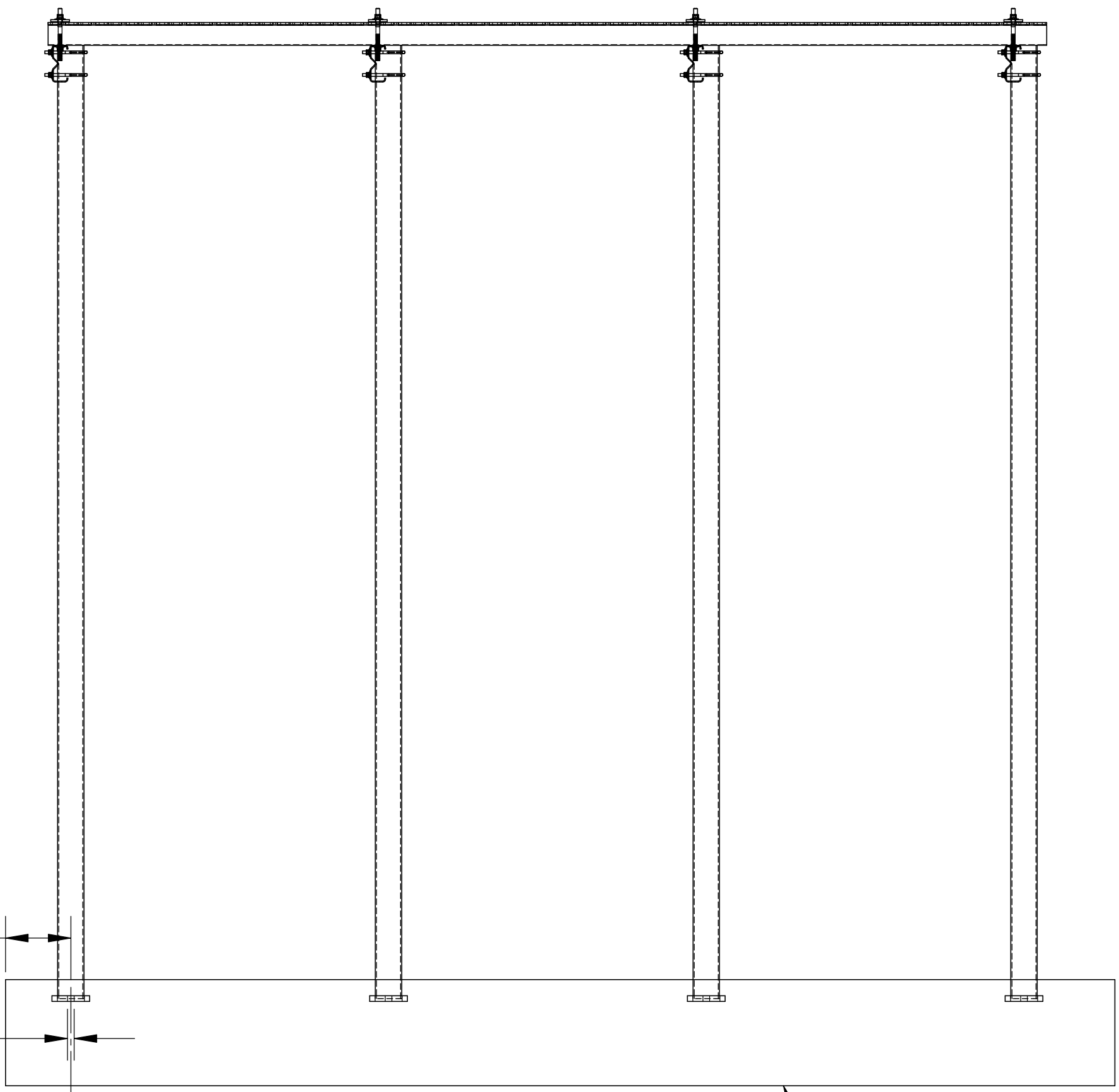

3.50" MINIMUM

Ø .88 [22.2]

CONCRETE SLAB BY OTHERS

COMMScope, INC. OF NORTH CAROLINA

TITLE

ICE CANOPY, 4 POSTS

SIZE  
**C**

SCALE  
**1:16**

DOCUMENT NO.  
**MTC4015132C**

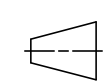

DRAWING			SHEET 2 OF 2
VERSION	STATUS	REVISION	
		A	

© 2015 CommScope, Inc. Confidential

4

3

2

1

D

D

C

C

B

B

A

A