

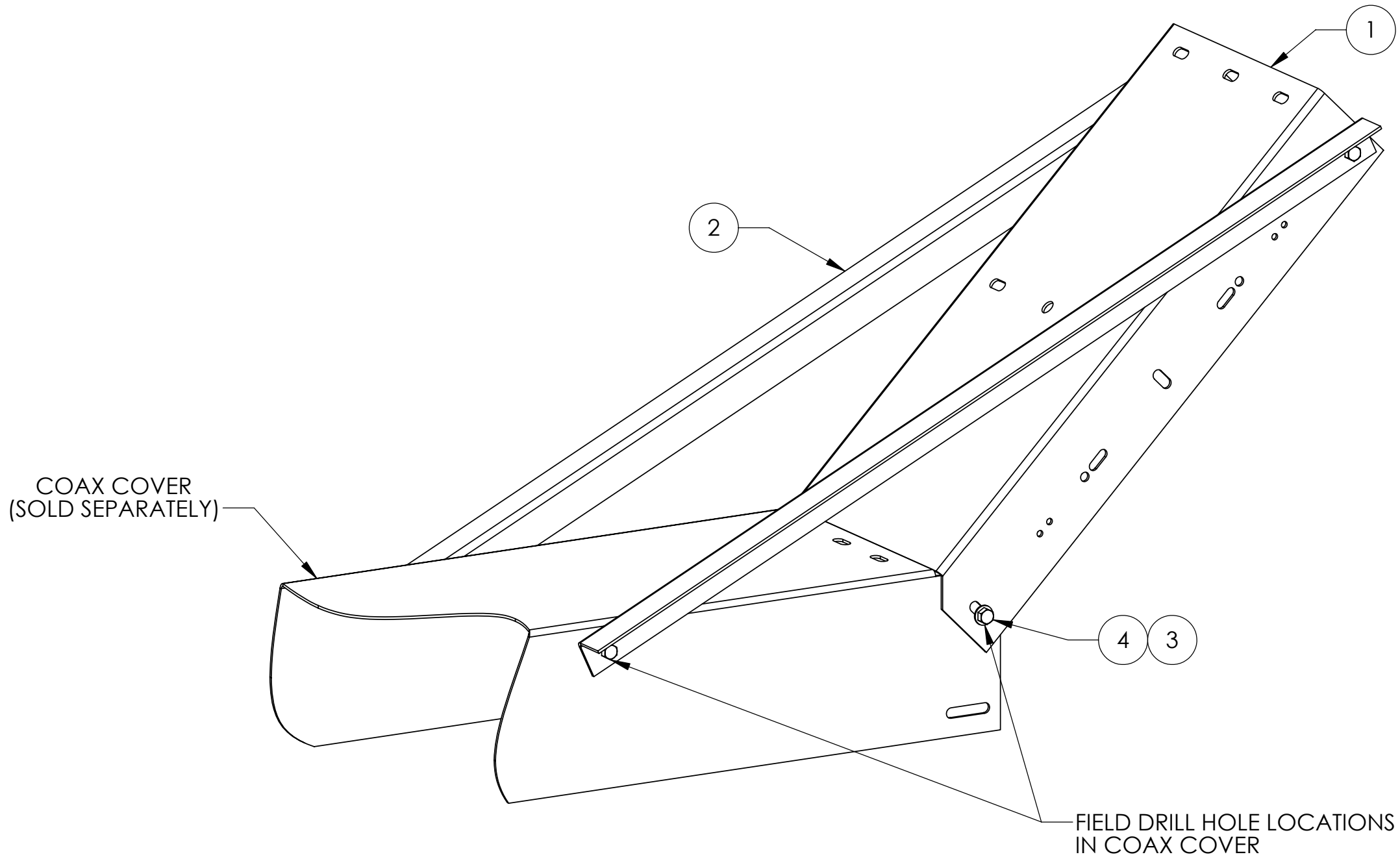

ITEM NO.	PART NUMBER	DESCRIPTION	QTY.	WEIGHT
1	MTF1133.01	EXTENSION KIT CHANNEL (4 RUN COAX)	1	16.69 LBS
2	MTF1133.02	FORMED ANGLE	2	4.25 LBS
3	GW-F03	3/8" GALV FLAT WASHER	4	0.01 LBS
4	GB-03105	3/8" X 1" GALV BOLT ASSY	6	0.07 LBS

REVISIONS				
REV.	ZONE	DESCRIPTION	BY	DATE
A		INITIAL RELEASE	JTS	04/30/01
B		REDRAWN	AW	06/30/06



<small>These drawings and specifications are the proprietary property of ANDREW CORPORATION and may be used only for the specific purpose authorized in writing by Andrew Corporation.</small> ALL DIMENSIONS ARE IN INCHES U.O.S. TOLERANCES UNLESS OTHERWISE SPECIFIED: .X = ± .06 ANGLES ± 2° .XX = ± .03 FRACTIONS ± 1/32 .XXX = ± .010 REMOVE BURRS AND BREAK EDGES .005 DO NOT SCALE THIS PRINT	<small>DRAWN BY:</small> JTS	<small>SHEET:</small> 1 of 1	<small>PART NUMBER:</small> MT-F1703
	<small>CHECKED BY:</small> TP	<small>SCALE:</small> NTS	<small>DESCRIPTION:</small> EXTENSION KIT FOR 4-RUN BRIDGE KIT
	<small>DATE:</small> 04/30/01	<small>MATERIAL:</small> A36	<small>DRAWING TYPE:</small> ASSEMBLY DRAWING
	<small>REVISION:</small> B	<small>FINISH:</small> GALV A123	 ANDREW ®
	<small>WEIGHT:</small> 25.23 LBS	ORLAND PARK, IL. 60462 U.S.A.	