

ITEM #	PART NUMBER	DESCRIPTION	QTY.	WEIGHT
1	MT366.01	SIDE PANEL	2	12.21LBS
2	MT366.02	TOP PANEL	1	38.27 LBS
3	MT366.03	FRONT ENTRY PANEL	1	12.72 LBS
4	MT366.04	COVER PANEL	2	6.46 LBS
5	MT366.05	BRACE	2	2.78 LBS
6	MT-366-H	HARDWARE KIT (ITEMS 7-11)	1	
7	RP-1004.AS	RECTANGULAR ENTRY PORT, 4 HOLE	1	3.26 LBS
8	SS-C1406	#14 X 3/4" SS TECH SCREW	22	0.01 LBS
9	SB-C0206	1/4 X 3/4 SS CARRIAGE BOLT	45	0.02 LBS
10	SW-L02	1/4" SS LOCK WASHER	45	0.01 LBS
11	SN-02	1/4" SS NUT	45	0.02 LBS
12	MT-46828	SILICONE SEALANT TUBE 2.5 oz. (NOT SHOWN)	1	0.16 LBS
13	RC-B	RECTANGULAR PORT CUSHION, BLANK (NOT SHOWN)	4	0.60 LBS
14	EP-HK04	HARDWARE KIT	2	
15	EP-HK05	HARDWARE KIT	1	

REVISIONS				
REV.	ZONE	DESCRIPTION	BY	DATE
B		REVISED AND UPDATE DRAWING	MLO	03/09/99
C		UPDATE MAT'L AND FINISH	ACG	04/04/03
D		UPDATED PARTS LIST	ACG	05/28/03
E		REDRAWN IN S.W.	AW	11/02/06

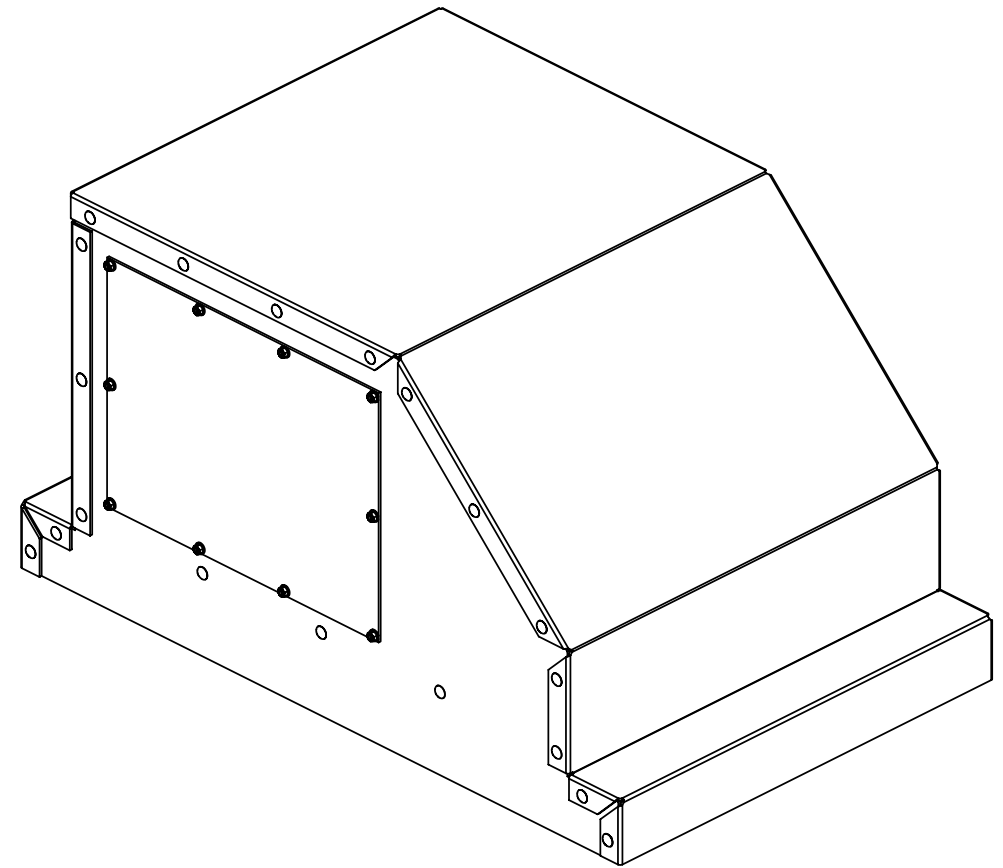
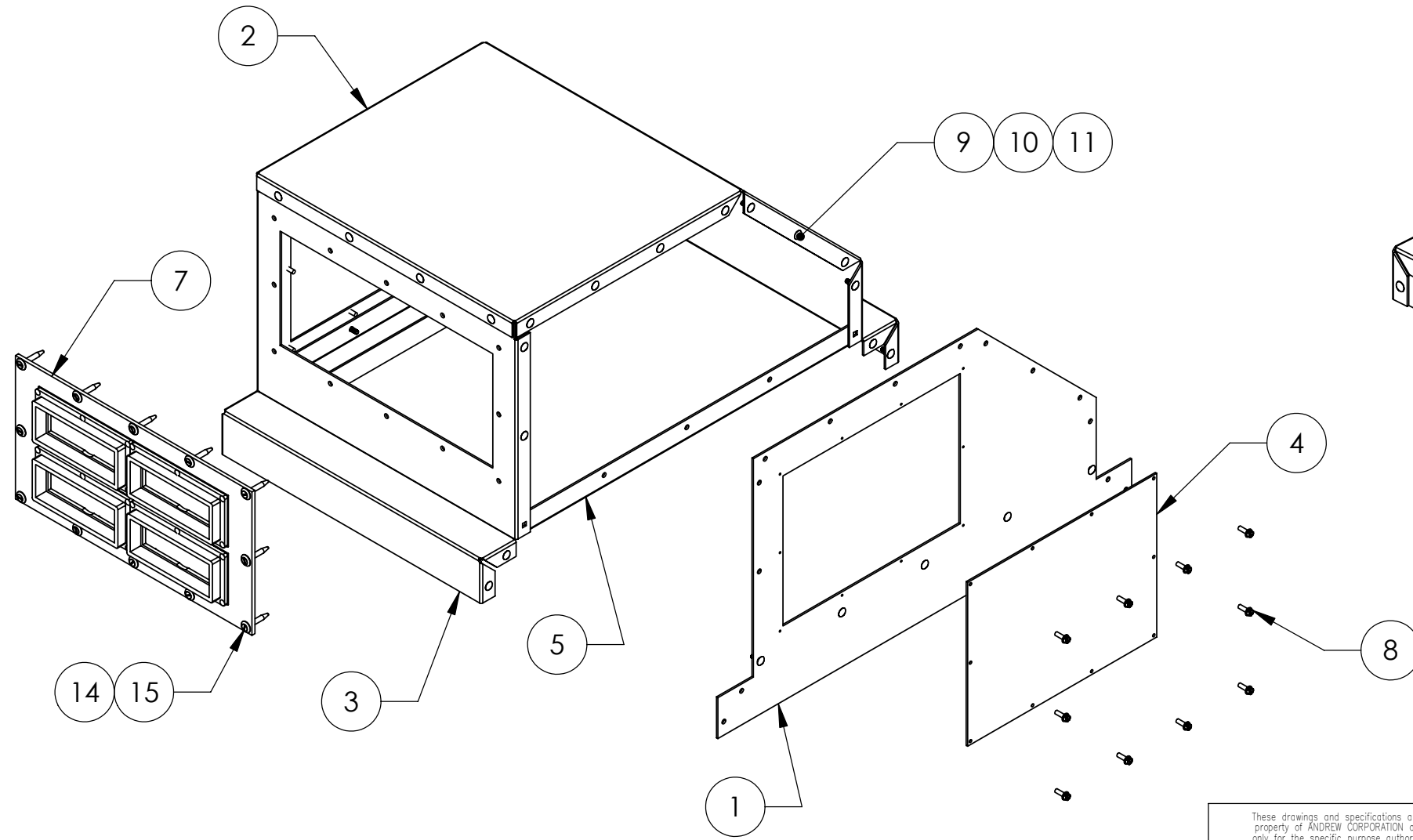

NOTES:
 1. APPLY SILICONE SEALANT TO ALL SEAMS

<small>These drawings and specifications are the proprietary property of ANDREW CORPORATION and may be used only for the specific purpose authorized in writing by Andrew Corporation.</small> ALL DIMENSIONS ARE IN INCHES U.O.S. TOLERANCES UNLESS OTHERWISE SPECIFIED: .X = ± .06 ANGLES ± 2' .XX = ± .03 FRACTIONS ± 1/32 .XXX = ± .010 REMOVE BURRS AND BREAK EDGES .005 DO NOT SCALE THIS PRINT	DRAWN BY: AW	SHEET: 1 of 1	PART NUMBER: MT-366
	CHECKED BY: TP	SCALE: NTS	DESCRIPTION: LOW PROFILE ROOF-TOP HOOD ENTRY
	DATE: 11/02/06	MATERIAL: A36	DRAWING TYPE: ASSEMBLY DRAWING
	REVISION: E	FINISH: POWDER COAT	WEIGHT: 97.27 LBS