

1 OPTICAL FIBER SPECIFICATIONS:

PART NUMBER	FIBER TYPE	CABLE TYPE	MAXIMUM	ATTENUATION db/km				OFL BANDWIDTH MHz-Km	
				850nm	1300nm	1310nm	1550nm	850nm	1300nm
X-1427436-1	62.5/125	OM1	MAXIMUM	3.5	1.5	N/A	N/A	200	600
X-1427436-2	50/125	OM2	MAXIMUM	3.5	1.5	N/A	N/A	500	500
X-1427436-3	50/125	OM3	MAXIMUM	3.5	1.5	N/A	N/A	1500	500
X-1427436-4	SM,G652D	OS2	MAXIMUM	N/A	NA	0.36	0.23	N/A	N/A
X-1427436-5	50/125	OM4	MAXIMUM	3.5	1.5	N/A	N/A	3500	500

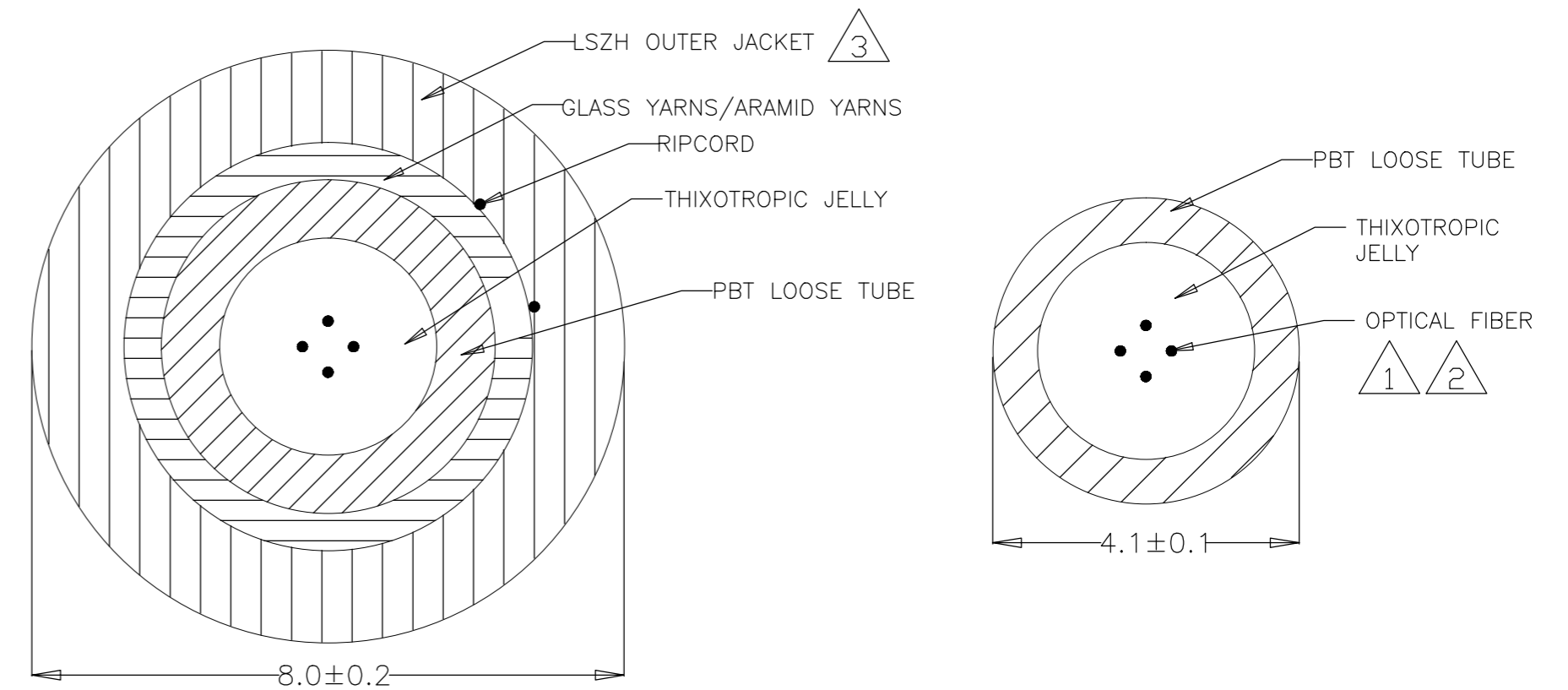

2 OPTICAL FIBERS TO BE COLOR-CODED BLUE, ORANGE, GREEN, BROWN PER TIA/EIA 598A.

3 CABLE OUTER JACKET:
A. OUTER JACKET MATERIAL TO BE LSZH.
B. JACKET COLOR TO BE BLACK.

4 RATINGS:
A. STORAGE TEMPERATURE: -40°C TO +70°C
B. OPERATING TEMPERATURE: -20°C TO +70°C
C. INSTALLATION TEMPERATURE: -10°C TO +60°C
D. MAXIMUM INSTALLATION TENSILE STRENGTH: 1800 N
E. MAXIMUM OPERATION TENSILE STRENGTH: 800 N
F. MINIMUM BEND RADIUS AT INSTALLATION: 20 TIMES CABLE DIAMETER
G. MINIMUM BEND RADIUS, UNLOADED: 10 TIMES CABLE DIAMETER
H. CRUSH RESISTANCE: 1000 N/10cm
I. CABLE WEIGHT: 73 KG/KM NOMINAL

5 MM/YY MONTH/YEAR - EXAMPLE: 06/16

6 XXXXX - SEQUENTIAL METER MARKING
TOLERANCE ON LENGTH MARKINGS: -0%/+10%

7 FIBER-CABLE TYPE-- "SM-OS2" FOR SINGLE MODE,
"62.5/125-OM1", "50/125-OM2", "50/125-OM3", "50/125-OM4" FOR MULTIMODE.

8 PRINT LEGEND ACCORDING 101-131550 METHOD A, LEGEND TO BE REPEATED EVERY METER IN INDENTED WHITE INK.

1 7 5 6
COMMSCOPE 8mm INDOOR/OUTDOOR OPTICAL CABLE X-1427436-Y 4F [Fiber type] LSZH [Batch code] MM/YY XXXX (M)

PART NUMBER LIST				
8-1427436-5	3-1427436-5	2-1427436-5	1-1427436-5	50/125-OM4
8-1427436-4	3-1427436-4	2-1427436-4	1-1427436-4	SM-OS2
8-1427436-3	3-1427436-3	2-1427436-3	1-1427436-3	50/125-OM3
8-1427436-2	3-1427436-2	2-1427436-2	1-1427436-2	50/125-OM2
8-1427436-1	3-1427436-1	2-1427436-1	1-1427436-1	62.5/125-OM1
CUT LENGTH	3000M	2000M	1000M	FIBER-CABLE TYPE

PACKAGED LENGTH			
DWN	07SEP2010	MATERIAL	HEAT TREAT
ENIAC XU		-	-
CHK		COMMSCOPE, INC.	
APVD	07SEP2010		
RICKY CHEN		NAME	
CABLE, FIBER OPTIC, INDOOR/OUTDOOR, LOOSE TUBE, LSZH, 4 FIBERS			
SCALE	SIZE	DRAWING NO	SHEET OF REV
-	A2	1427436	1 OF 1 D

DIMENSIONS:		TOLERANCES UNLESS OTHERWISE SPECIFIED:	
mm		0 PLC ± -	
		1 PLC ± -	
		2 PLC ± -	
		3 PLC ± -	
		4 PLC ± -	
ANGLES±	-		
SURFACE TEXTURE	√		

P	LTR	REVISION RECORD	DATE	DWN	APVD
D		40031180MCO	3JUN16	M.D	T.V