

# F1A-PDMSM-M5

---

FSJ1-50A SureFlex® Jumper with interface types SMA Male and 7-16  
DIN Male, 0.5 m



## Product Classification

<b>Product Type</b>	SureFlex® standard
<b>Product Brand</b>	HELIAX®   SureFlex®
<b>Product Series</b>	FSJ1-50A

## General Specifications

<b>Body Style, Connector A</b>	Straight
<b>Body Style, Connector B</b>	Straight
<b>Interface, Connector A</b>	SMA Male
<b>Interface, Connector B</b>	7-16 DIN Male
<b>Specification Sheet Revision Level</b>	A

## Dimensions

<b>Length</b>	0.5 m   1.64 ft
<b>Nominal Size</b>	1/4 in

## VSWR/Return Loss

<b>Frequency Band</b>	<b>VSWR</b>	<b>Return Loss (dB)</b>
<b>700–3000 MHz</b>	1.222	20.01

## Jumper Assembly Sample Label

# F1A-PDMSM-M5



## Environmental Specifications

**Immersion Test Method** Meets IEC 60529:2001, IP68 in mated condition

## Regulatory Compliance/Certifications

Agency	Classification
ISO 9001:2015	Designed, manufactured and/or distributed under this quality management system

## Included Products

- 35422-33 – Heat Treated FSJ1-50A, HELIAX® Superflexible Low Density Foam Coaxial Cable, corrugated copper, 1/4 in, black PE Jacket
- 35422-75 – Heat Treated FSJ1RK-50B, HELIAX® Superflexible Foam Coaxial Cable, corrugated copper, 1/4 in, black non-halogenated, fire retardant polyolefin jacket
- F1TSM-C – SMA Male for 1/4 in FSJ1-50A cable
- FSJ1-50A – FSJ1-50A, HELIAX® Superflexible Low Density Foam Coaxial Cable, corrugated copper, 1/4 in, black PE jacket
- FSJ1RK-50A – FSJ1-50A, HELIAX® Superflexible Foam Coaxial Cable, corrugated copper, 1/4 in, black non-halogenated, fire retardant polyolefin jacket, B2ca s1a d0 a1 Compliant



Heat Treated FSJ1-50A, HELIAX® Superflexible Low Density Foam Coaxial Cable, corrugated copper, 1/4 in, black PE Jacket

## Product Classification

<b>Product Type</b>	Coaxial wireless cable
<b>Product Brand</b>	HELIAX®
<b>Product Series</b>	FSJ1-50A

## General Specifications

<b>Flexibility</b>	Superflexible
<b>Jacket Color</b>	Black
<b>Performance Note</b>	Attenuation values typical, guaranteed within 5%

## Dimensions

<b>Diameter Over Dielectric</b>	4.826 mm   0.19 in
<b>Diameter Over Jacket</b>	7.366 mm   0.29 in
<b>Inner Conductor OD</b>	1.905 mm   0.075 in
<b>Outer Conductor OD</b>	6.35 mm   0.25 in
<b>Nominal Size</b>	1/4 in

## Electrical Specifications

<b>Cable Impedance</b>	50 ohm ±1 ohm
<b>Capacitance</b>	79.4 pF/m   24.201 pF/ft
<b>dc Resistance, Inner Conductor</b>	9.843 ohms/km   3 ohms/kft
<b>dc Resistance, Outer Conductor</b>	6.562 ohms/km   2 ohms/kft
<b>dc Test Voltage</b>	1600 V
<b>Inductance</b>	0.2 µH/m   0.061 µH/ft
<b>Insulation Resistance</b>	100000 MOhms-km

# 35422-33

---

<b>Jacket Spark Test Voltage (rms)</b>	5000 V
<b>Operating Frequency Band</b>	1 – 18000 MHz
<b>Peak Power</b>	6.4 kW
<b>Velocity</b>	82 %

## VSWR/Return Loss

<b>Frequency Band</b>	<b>VSWR</b>	<b>Return Loss (dB)</b>
<b>680–960 MHz</b>	1.201	20.79
<b>1700–2200 MHz</b>	1.201	20.79
<b>2200–2700 MHz</b>	1.433	14.99

## Attenuation

<b>Frequency (MHz)</b>	<b>Attenuation (dB/100 m)</b>	<b>Attenuation (dB/100 ft)</b>
<b>0.5</b>	0.407	0.124
<b>1.0</b>	0.577	0.176
<b>1.5</b>	0.707	0.215
<b>2.0</b>	0.816	0.249
<b>10.0</b>	1.833	0.559
<b>20.0</b>	2.6	0.792
<b>30.0</b>	3.192	0.973
<b>50.0</b>	4.136	1.261
<b>85.0</b>	5.419	1.652
<b>88.0</b>	5.516	1.681
<b>100.0</b>	5.889	1.795
<b>108.0</b>	6.12	1.867
<b>150.0</b>	7.25	2.21
<b>174.0</b>	7.825	2.385
<b>200.0</b>	8.408	2.563
<b>204.0</b>	8.495	2.589
<b>300.0</b>	10.373	3.162
<b>400.0</b>	12.051	3.673
<b>450.0</b>	12.817	3.906
<b>500.0</b>	13.545	4.128
<b>512.0</b>	13.715	4.18
<b>600.0</b>	14.909	4.544

# 35422-33

---

700.0	16.175	4.93
800.0	17.362	5.292
824.0	17.637	5.376
894.0	18.42	5.614
960.0	19.134	5.832
1000.0	19.556	5.96
1218.0	21.738	6.626
1250.0	22.044	6.719
1500.0	24.326	7.414
1700.0	26.038	7.936
1794.0	26.813	8.172
1800.0	26.862	8.187
2000.0	28.455	8.673
2100.0	29.227	8.908
2200.0	29.984	9.139
2300.0	30.727	9.365
2500.0	32.174	9.806
2700.0	33.576	10.233
3000.0	35.602	10.851
3400.0	38.183	11.638
3700.0	40.041	12.204
4000.0	41.841	12.753
5000.0	47.5	14.477
6000.0	52.747	16.077
8000.0	62.37	19.01
8800.0	65.974	20.108
10000.0	71.173	21.693
12000.0	79.393	24.198
14000.0	87.172	26.569
15800.0	93.872	28.611
16000.0	94.601	28.833
18000.0	101.745	31.01

## Material Specifications

**Dielectric Material**

Foam PE

**Jacket Material**

PE

# 35422-33

---

<b>Inner Conductor Material</b>	Copper-clad aluminum wire
<b>Outer Conductor Material</b>	Corrugated copper

## Mechanical Specifications

<b>Minimum Bend Radius, multiple Bends</b>	25.4 mm   1 in
<b>Minimum Bend Radius, single Bend</b>	25.4 mm   1 in
<b>Number of Bends, minimum</b>	15
<b>Number of Bends, typical</b>	20
<b>Tensile Strength</b>	68 kg   149.914 lb
<b>Bending Moment</b>	1.1 N-m   9.736 in lb
<b>Flat Plate Crush Strength</b>	1.8 kg/mm   100.795 lb/in

## Environmental Specifications

<b>Installation temperature</b>	-40 °C to +60 °C (-40 °F to +140 °F)
<b>Operating Temperature</b>	-55 °C to +85 °C (-67 °F to +185 °F)
<b>Storage Temperature</b>	-70 °C to +85 °C (-94 °F to +185 °F)
<b>Attenuation, Ambient Temperature</b>	68 °F   20 °C
<b>Average Power, Ambient Temperature</b>	104 °F   40 °C
<b>Average Power, Inner Conductor Temperature</b>	212 °F   100 °C

## Packaging and Weights

<b>Cable weight</b>	0.07 kg/m   0.047 lb/ft
---------------------	-------------------------

## Regulatory Compliance/Certifications

<b>Agency</b>	<b>Classification</b>
ISO 9001:2015	Designed, manufactured and/or distributed under this quality management system
UL/ETL Certification	Compliant



# 35422-75

---



Heat Treated FSJ1RK-50B, HELIAX® Superflexible Foam Coaxial Cable, corrugated copper, 1/4 in, black non-halogenated, fire retardant polyolefin jacket

## Product Classification

<b>Product Type</b>	Coaxial wireless cable
<b>Product Brand</b>	HELIAX®
<b>Product Series</b>	FSJ1-50B

## General Specifications

<b>Flexibility</b>	Superflexible
<b>Jacket Color</b>	Black
<b>Performance Note</b>	Attenuation values typical, guaranteed within 5%

## Dimensions

<b>Diameter Over Dielectric</b>	4.826 mm   0.19 in
<b>Diameter Over Jacket</b>	7.62 mm   0.3 in
<b>Inner Conductor OD</b>	1.905 mm   0.075 in
<b>Outer Conductor OD</b>	6.35 mm   0.25 in
<b>Nominal Size</b>	1/4 in

## Electrical Specifications

<b>Cable Impedance</b>	50 ohm ±1 ohm
<b>Capacitance</b>	79.4 pF/m   24.201 pF/ft
<b>dc Resistance, Inner Conductor</b>	9.843 ohms/km   3 ohms/kft
<b>dc Resistance, Outer Conductor</b>	6.562 ohms/km   2 ohms/kft
<b>dc Test Voltage</b>	1600 V
<b>Inductance</b>	0.2 µH/m   0.061 µH/ft
<b>Insulation Resistance</b>	100000 MOhms-km

# 35422-75

<b>Jacket Spark Test Voltage (rms)</b>	4000 V
<b>Operating Frequency Band</b>	1 – 18000 MHz
<b>Peak Power</b>	6.4 kW
<b>Velocity</b>	82 %

## VSWR/Return Loss

<b>Frequency Band</b>	<b>VSWR</b>	<b>Return Loss (dB)</b>
<b>680–960 MHz</b>	1.201	20.79
<b>1700–2200 MHz</b>	1.201	20.79
<b>2200–2700 MHz</b>	1.433	14.99

## Attenuation

<b>Frequency (MHz)</b>	<b>Attenuation (dB/100 m)</b>	<b>Attenuation (dB/100 ft)</b>	<b>Average Power (kW)</b>
<b>1.0</b>	0.577	0.176	6.4
<b>1.5</b>	0.707	0.215	6.4
<b>2.0</b>	0.816	0.249	6.4
<b>10.0</b>	1.833	0.559	3.99
<b>20.0</b>	2.6	0.792	2.81
<b>30.0</b>	3.192	0.973	2.29
<b>50.0</b>	4.136	1.261	1.77
<b>85.0</b>	5.419	1.652	1.35
<b>88.0</b>	5.516	1.681	1.33
<b>100.0</b>	5.889	1.795	1.24
<b>108.0</b>	6.125	1.867	1.19
<b>150.0</b>	7.25	2.21	1.01
<b>174.0</b>	7.825	2.385	0.93
<b>200.0</b>	8.408	2.563	0.87
<b>204.0</b>	8.495	2.589	0.86
<b>300.0</b>	10.373	3.162	0.71
<b>400.0</b>	12.051	3.673	0.61
<b>450.0</b>	12.817	3.906	0.57
<b>460.0</b>	12.965	3.952	0.56
<b>500.0</b>	13.545	4.128	0.54
<b>512.0</b>	13.715	4.18	0.53
<b>600.0</b>	14.909	4.544	0.49



# 35422-75

---

<b>700.0</b>	16.175	4.93	0.45
<b>800.0</b>	17.362	5.292	0.42
<b>824.0</b>	17.637	5.376	0.41
<b>894.0</b>	18.42	5.614	0.4
<b>960.0</b>	19.134	5.832	0.38
<b>1000.0</b>	19.556	5.96	0.37
<b>1218.0</b>	21.738	6.626	0.34
<b>1250.0</b>	22.044	6.719	0.33
<b>1500.0</b>	24.326	7.414	0.3
<b>1700.0</b>	26.038	7.936	0.28
<b>1794.0</b>	26.813	8.172	0.27
<b>1800.0</b>	26.862	8.187	0.27
<b>2000.0</b>	28.455	8.673	0.26
<b>2100.0</b>	29.227	8.908	0.25
<b>2200.0</b>	29.984	9.139	0.24
<b>2300.0</b>	30.727	9.365	0.24
<b>2500.0</b>	32.174	9.806	0.23
<b>2700.0</b>	33.576	10.233	0.22
<b>3000.0</b>	35.602	10.851	0.21
<b>3400.0</b>	38.183	11.638	0.19
<b>3600.0</b>	39.428	12.017	0.19
<b>3700.0</b>	40.041	12.204	0.18
<b>3800.0</b>	40.647	12.389	0.18
<b>3900.0</b>	41.247	12.571	0.18
<b>4000.0</b>	41.841	12.753	0.17
<b>4100.0</b>	42.429	12.932	0.17
<b>4200.0</b>	43.012	13.11	0.17
<b>4300.0</b>	43.59	13.286	0.17
<b>4400.0</b>	44.163	13.46	0.17
<b>4500.0</b>	44.73	13.633	0.16
<b>4600.0</b>	45.293	13.805	0.16
<b>4700.0</b>	45.852	13.975	0.16
<b>4800.0</b>	46.405	14.144	0.16
<b>4900.0</b>	46.955	14.311	0.16
<b>5000.0</b>	47.5	14.477	0.15

# 35422-75

<b>6000.0</b>	52.747	16.077	0.14
<b>8000.0</b>	62.37	19.01	0.12
<b>8800.0</b>	65.974	20.108	0.11
<b>10000.0</b>	71.173	21.693	0.1
<b>12000.0</b>	79.393	24.198	0.09
<b>14000.0</b>	87.172	26.569	0.08
<b>15800.0</b>	93.872	28.611	0.08
<b>16000.0</b>	94.601	28.833	0.08
<b>18000.0</b>	101.745	31.01	0.07

## Material Specifications

<b>Dielectric Material</b>	Foam PE
<b>Jacket Material</b>	Non-halogenated, fire retardant polyolefin
<b>Inner Conductor Material</b>	Copper-clad aluminum wire
<b>Outer Conductor Material</b>	Corrugated copper

## Mechanical Specifications

<b>Minimum Bend Radius, multiple Bends</b>	25.4 mm   1 in
<b>Minimum Bend Radius, single Bend</b>	25.4 mm   1 in
<b>Number of Bends, minimum</b>	15
<b>Number of Bends, typical</b>	20
<b>Tensile Strength</b>	68 kg   149.914 lb
<b>Bending Moment</b>	1.1 N-m   9.736 in lb
<b>Flat Plate Crush Strength</b>	1.8 kg/mm   100.795 lb/in

## Environmental Specifications

<b>Installation temperature</b>	-40 °C to +60 °C (-40 °F to +140 °F)
<b>Operating Temperature</b>	-40 °C to +60 °C (-40 °F to +140 °F)
<b>Storage Temperature</b>	-40 °C to +60 °C (-40 °F to +140 °F)
<b>Attenuation, Ambient Temperature</b>	68 °F   20 °C
<b>Average Power, Ambient Temperature</b>	104 °F   40 °C
<b>Average Power, Inner Conductor Temperature</b>	212 °F   100 °C
<b>Fire Retardancy Test Method</b>	UL 1666/CATVR/CMR
<b>Smoke Index Test Method</b>	IEC 61034

# 35422-75

---

## Toxicity Index Test Method

IEC 60754-1 | IEC 60754-2

## Packaging and Weights

### Cable weight

0.07 kg/m | 0.047 lb/ft

## Regulatory Compliance/Certifications

### Agency

### Classification

ISO 9001:2015

Designed, manufactured and/or distributed under this quality management system

UL/ETL Certification

Compliant



# F1TSM-C

---

SMA Male for 1/4 in FSJ1-50A cable



## Product Classification

<b>Product Type</b>	Wireless and radiating connector
<b>Product Brand</b>	HELIAX®
<b>Product Series</b>	FSJ1-50A

## General Specifications

<b>Body Style</b>	Straight
<b>Cable Family</b>	FSJ1-50A
<b>Inner Contact Attachment Method</b>	Captivated
<b>Inner Contact Plating</b>	Gold
<b>Interface</b>	SMA Male
<b>Mounting Angle</b>	Straight
<b>Outer Contact Attachment Method</b>	Self-clamping
<b>Outer Contact Plating</b>	Trimetal
<b>Pressurizable</b>	No

## Dimensions

<b>Height</b>	14.22 mm   0.56 in
<b>Width</b>	14.22 mm   0.56 in
<b>Length</b>	36.58 mm   1.44 in
<b>Diameter</b>	14.22 mm   0.56 in
<b>Nominal Size</b>	1/4 in

## Outline Drawing

# F1TSM-C

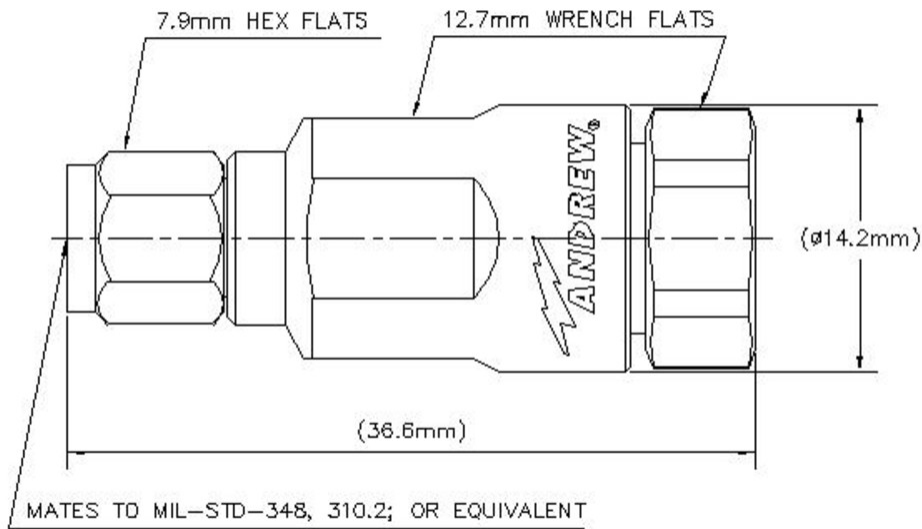

## Electrical Specifications

<b>Average Power at Frequency</b>	0.4 kW @ 900 MHz
<b>Cable Impedance</b>	50 ohm
<b>Connector Impedance</b>	50 ohm
<b>dc Test Voltage</b>	1000 V
<b>Inner Contact Resistance, maximum</b>	3 mOhm
<b>Insulation Resistance, minimum</b>	5000 MOhm
<b>Operating Frequency Band</b>	0 – 6000 MHz
<b>Outer Contact Resistance, maximum</b>	2.5 mOhm
<b>Peak Power, maximum</b>	5 kW
<b>RF Operating Voltage, maximum (vrms)</b>	500 V
<b>Shielding Effectiveness</b>	-110 dB

## VSWR/Return Loss

Frequency Band	VSWR	Return Loss (dB)
0–3000 MHz	1.173	21.98
3000–6000 MHz	1.222	20.01
6000–9000 MHz	1.29	18

## Mechanical Specifications

# F1TSM-C

---

<b>Connector Retention Tensile Force</b>	449.27 N   101 lbf
<b>Coupling Nut Proof Torque</b>	1.7 N-m   15.046 in lb
<b>Coupling Nut Proof Torque Method</b>	IEC 61169-16:9.3.11
<b>Coupling Nut Retention Force</b>	266.98 N   60.02 lbf
<b>Coupling Nut Retention Force Method</b>	IEC 61169-15:9.3.11
<b>Insertion Force</b>	97.86 N   22 lbf
<b>Insertion Force Method</b>	IEC 61169-16:9.3.5
<b>Interface Durability</b>	500 cycles
<b>Interface Durability Method</b>	IEC 61169-4:17
<b>Mechanical Shock Test Method</b>	IEC 60068-2-27

## Environmental Specifications

<b>Operating Temperature</b>	-55 °C to +85 °C (-67 °F to +185 °F)
<b>Storage Temperature</b>	-65 °C to +125 °C (-85 °F to +257 °F)
<b>Attenuation, Ambient Temperature</b>	20 °C   68 °F
<b>Average Power, Ambient Temperature</b>	40 °C   104 °F
<b>Average Power, Inner Conductor Temperature</b>	100 °C   212 °F
<b>Corrosion Test Method</b>	IEC 60068-2-11
<b>Moisture Resistance Test Method</b>	IEC 60068-2-3
<b>Thermal Shock Test Method</b>	IEC 60068-2-14
<b>Vibration Test Method</b>	IEC 60068-2-6

## Packaging and Weights

<b>Weight, net</b>	24.99 g   0.055 lb
--------------------	--------------------

## Regulatory Compliance/Certifications

<b>Agency</b>	<b>Classification</b>
CHINA-ROHS	Below maximum concentration value
ISO 9001:2015	Designed, manufactured and/or distributed under this quality management system
REACH-SVHC	Compliant as per SVHC revision on <a href="http://www.commscope.com/ProductCompliance">www.commscope.com/ProductCompliance</a>
ROHS	Compliant
UK-ROHS	Compliant/Exempted



# FSJ1-50A

---



FSJ1-50A, HELIAX® Superflexible Low Density Foam Coaxial Cable, corrugated copper, 1/4 in, black PE jacket

## Product Classification

<b>Product Type</b>	Coaxial wireless cable
<b>Product Brand</b>	HELIAX®   SureFlex®
<b>Product Series</b>	FSJ1-50A   MLOC

## General Specifications

<b>Product Number</b>	887009902/00   SZ887009902/00
<b>Flexibility</b>	Superflexible
<b>Jacket Color</b>	Black
<b>Performance Note</b>	Attenuation values typical, guaranteed within 5%

## Dimensions

<b>Diameter Over Dielectric</b>	4.826 mm   0.19 in
<b>Diameter Over Jacket</b>	7.366 mm   0.29 in
<b>Inner Conductor OD</b>	1.905 mm   0.075 in
<b>Outer Conductor OD</b>	6.35 mm   0.25 in
<b>Nominal Size</b>	1/4 in

## Electrical Specifications

<b>Cable Impedance</b>	50 ohm $\pm$ 1 ohm
<b>Capacitance</b>	79.4 pF/m   24.201 pF/ft
<b>dc Resistance, Inner Conductor</b>	9.843 ohms/km   3 ohms/kft
<b>dc Resistance, Outer Conductor</b>	7.216 ohms/km   2.199 ohms/kft
<b>dc Test Voltage</b>	1600 V
<b>Inductance</b>	0.2 $\mu$ H/m   0.061 $\mu$ H/ft

# FSJ1-50A

<b>Insulation Resistance</b>	100000 MOhms-km
<b>Jacket Spark Test Voltage (rms)</b>	5000 V
<b>Operating Frequency Band</b>	1 – 18000 MHz
<b>Peak Power</b>	6.4 kW
<b>Velocity</b>	82 %

## VSWR/Return Loss

<b>Frequency Band</b>	<b>VSWR</b>	<b>Return Loss (dB)</b>
<b>680–960 MHz</b>	1.201	20.8
<b>1700–2200 MHz</b>	1.201	20.8
<b>2200–2700 MHz</b>	1.433	15

## Attenuation

<b>Frequency (MHz)</b>	<b>Attenuation (dB/100 m)</b>	<b>Attenuation (dB/100 ft)</b>	<b>Average Power (kW)</b>
<b>1.0</b>	0.577	0.176	6.4
<b>1.5</b>	0.707	0.215	6.4
<b>2.0</b>	0.816	0.249	6.4
<b>10.0</b>	1.833	0.559	3.99
<b>20.0</b>	2.6	0.792	2.81
<b>30.0</b>	3.192	0.973	2.29
<b>50.0</b>	4.136	1.261	1.77
<b>85.0</b>	5.419	1.652	1.35
<b>88.0</b>	5.516	1.681	1.33
<b>100.0</b>	5.889	1.795	1.24
<b>108.0</b>	6.125	1.867	1.19
<b>150.0</b>	7.25	2.21	1.01
<b>174.0</b>	7.825	2.385	0.93
<b>200.0</b>	8.408	2.563	0.87
<b>204.0</b>	8.495	2.589	0.86
<b>300.0</b>	10.373	3.162	0.71
<b>400.0</b>	12.051	3.673	0.61
<b>450.0</b>	12.817	3.906	0.57
<b>460.0</b>	12.965	3.952	0.56
<b>500.0</b>	13.545	4.128	0.54
<b>512.0</b>	13.715	4.18	0.53



# FSJ1-50A

---

<b>600.0</b>	14.909	4.544	0.49
<b>700.0</b>	16.175	4.93	0.45
<b>800.0</b>	17.362	5.292	0.42
<b>824.0</b>	17.637	5.376	0.41
<b>894.0</b>	18.42	5.614	0.4
<b>960.0</b>	19.134	5.832	0.38
<b>1000.0</b>	19.556	5.96	0.37
<b>1218.0</b>	21.738	6.626	0.34
<b>1250.0</b>	22.044	6.719	0.33
<b>1500.0</b>	24.326	7.414	0.3
<b>1700.0</b>	26.038	7.936	0.28
<b>1794.0</b>	26.813	8.172	0.27
<b>1800.0</b>	26.862	8.187	0.27
<b>2000.0</b>	28.455	8.673	0.26
<b>2100.0</b>	29.227	8.908	0.25
<b>2200.0</b>	29.984	9.139	0.24
<b>2300.0</b>	30.727	9.365	0.24
<b>2500.0</b>	32.174	9.806	0.23
<b>2700.0</b>	33.576	10.233	0.22
<b>3000.0</b>	35.602	10.851	0.21
<b>3400.0</b>	38.183	11.638	0.19
<b>3600.0</b>	39.428	12.017	0.19
<b>3700.0</b>	40.041	12.204	0.18
<b>3800.0</b>	40.647	12.389	0.18
<b>3900.0</b>	41.247	12.571	0.18
<b>4000.0</b>	41.841	12.753	0.17
<b>4100.0</b>	42.429	12.932	0.17
<b>4200.0</b>	43.012	13.11	0.17
<b>4300.0</b>	43.59	13.286	0.17
<b>4400.0</b>	44.163	13.46	0.17
<b>4500.0</b>	44.73	13.633	0.16
<b>4600.0</b>	45.293	13.805	0.16
<b>4700.0</b>	45.852	13.975	0.16
<b>4800.0</b>	46.405	14.144	0.16
<b>4900.0</b>	46.955	14.311	0.16

# FSJ1-50A

5000.0	47.5	14.477	0.15
6000.0	52.747	16.077	0.14
8000.0	62.37	19.01	0.12
8800.0	65.974	20.108	0.11
10000.0	71.173	21.693	0.1
12000.0	79.393	24.198	0.09
14000.0	87.172	26.569	0.08
15800.0	93.872	28.611	0.08
16000.0	94.601	28.833	0.08
18000.0	101.745	31.01	0.07

## Material Specifications

<b>Dielectric Material</b>	Foam PE
<b>Jacket Material</b>	PE
<b>Inner Conductor Material</b>	Copper-clad aluminum wire
<b>Outer Conductor Material</b>	Corrugated copper

## Mechanical Specifications

<b>Minimum Bend Radius, multiple Bends</b>	25.4 mm   1 in
<b>Minimum Bend Radius, single Bend</b>	25.4 mm   1 in
<b>Number of Bends, minimum</b>	15
<b>Number of Bends, typical</b>	20
<b>Tensile Strength</b>	68 kg   149.914 lb
<b>Bending Moment</b>	0.7 N-m   6.196 in lb
<b>Flat Plate Crush Strength</b>	1.8 kg/mm   100.795 lb/in

## Environmental Specifications

<b>Installation temperature</b>	-40 °C to +60 °C (-40 °F to +140 °F)
<b>Operating Temperature</b>	-55 °C to +85 °C (-67 °F to +185 °F)
<b>Storage Temperature</b>	-70 °C to +85 °C (-94 °F to +185 °F)
<b>Attenuation, Ambient Temperature</b>	68 °F   20 °C
<b>Average Power, Ambient Temperature</b>	104 °F   40 °C
<b>Average Power, Inner Conductor Temperature</b>	212 °F   100 °C

# FSJ1-50A

---

## Packaging and Weights

### Cable weight

0.07 kg/m | 0.047 lb/ft

## Regulatory Compliance/Certifications

### Agency

### Classification

CHINA-ROHS

Below maximum concentration value

ISO 9001:2015

Designed, manufactured and/or distributed under this quality management system

REACH-SVHC

Compliant as per SVHC revision on [www.commscope.com/ProductCompliance](http://www.commscope.com/ProductCompliance)

ROHS

Compliant

UK-ROHS

Compliant

UL/ETL Certification

Compliant



# FSJ1RK-50A

---

FSJ1-50A, HELIAX® Superflexible Foam Coaxial Cable, corrugated copper, 1/4 in, black non-halogenated, fire retardant polyolefin jacket, B2ca s1a d0 a1 Compliant

## Product Classification

<b>Product Type</b>	Coaxial wireless cable
<b>Product Brand</b>	HELIAX®   SureFlex®
<b>Product Series</b>	FSJ1-50A   MLOC

## General Specifications

<b>Flexibility</b>	Superflexible
<b>Jacket Color</b>	Black
<b>Performance Note</b>	Attenuation values typical, guaranteed within 5%

## Dimensions

<b>Diameter Over Dielectric</b>	4.826 mm   0.19 in
<b>Diameter Over Jacket</b>	7.62 mm   0.3 in
<b>Inner Conductor OD</b>	1.905 mm   0.075 in
<b>Outer Conductor OD</b>	6.35 mm   0.25 in
<b>Nominal Size</b>	1/4 in

## Electrical Specifications

<b>Cable Impedance</b>	50 ohm ±1 ohm
<b>Capacitance</b>	79.4 pF/m   24.201 pF/ft
<b>dc Resistance, Inner Conductor</b>	9.843 ohms/km   3 ohms/kft
<b>dc Resistance, Outer Conductor</b>	7.216 ohms/km   2.199 ohms/kft
<b>dc Test Voltage</b>	1600 V
<b>Inductance</b>	0.2 µH/m   0.061 µH/ft
<b>Insulation Resistance</b>	100000 MOhms-km
<b>Jacket Spark Test Voltage (rms)</b>	4000 V
<b>Operating Frequency Band</b>	1 – 18000 MHz
<b>Peak Power</b>	6.4 kW
<b>Velocity</b>	82 %

# FSJ1RK-50A

---

## VSWR/Return Loss

Frequency Band	VSWR	Return Loss (dB)
680–960 MHz	1.201	20.79
1700–2200 MHz	1.201	20.79
2200–2700 MHz	1.433	14.99

## Attenuation

Frequency (MHz)	Attenuation (dB/100 m)	Attenuation (dB/100 ft)	Average Power (kW)
1.0	0.577	0.176	6.4
1.5	0.707	0.215	6.4
2.0	0.816	0.249	6.4
10.0	1.833	0.559	3.99
20.0	2.6	0.792	2.81
30.0	3.192	0.973	2.29
50.0	4.136	1.261	1.77
85.0	5.419	1.652	1.35
88.0	5.516	1.681	1.33
100.0	5.889	1.795	1.24
108.0	6.125	1.867	1.19
150.0	7.25	2.21	1.01
174.0	7.825	2.385	0.93
200.0	8.408	2.563	0.87
204.0	8.495	2.589	0.86
300.0	10.373	3.162	0.71
400.0	12.051	3.673	0.61
450.0	12.817	3.906	0.57
460.0	12.965	3.952	0.56
500.0	13.545	4.128	0.54
512.0	13.715	4.18	0.53
600.0	14.909	4.544	0.49
700.0	16.175	4.93	0.45
800.0	17.362	5.292	0.42
824.0	17.637	5.376	0.41

# FSJ1RK-50A

---

<b>894.0</b>	18.42	5.614	0.4
<b>960.0</b>	19.134	5.832	0.38
<b>1000.0</b>	19.556	5.96	0.37
<b>1218.0</b>	21.738	6.626	0.34
<b>1250.0</b>	22.044	6.719	0.33
<b>1500.0</b>	24.326	7.414	0.3
<b>1700.0</b>	26.038	7.936	0.28
<b>1794.0</b>	26.813	8.172	0.27
<b>1800.0</b>	26.862	8.187	0.27
<b>2000.0</b>	28.455	8.673	0.26
<b>2100.0</b>	29.227	8.908	0.25
<b>2200.0</b>	29.984	9.139	0.24
<b>2300.0</b>	30.727	9.365	0.24
<b>2500.0</b>	32.174	9.806	0.23
<b>2700.0</b>	33.576	10.233	0.22
<b>3000.0</b>	35.602	10.851	0.21
<b>3400.0</b>	38.183	11.638	0.19
<b>3600.0</b>	39.428	12.017	0.19
<b>3700.0</b>	40.041	12.204	0.18
<b>3800.0</b>	40.647	12.389	0.18
<b>3900.0</b>	41.247	12.571	0.18
<b>4000.0</b>	41.841	12.753	0.17
<b>4100.0</b>	42.429	12.932	0.17
<b>4200.0</b>	43.012	13.11	0.17
<b>4300.0</b>	43.59	13.286	0.17
<b>4400.0</b>	44.163	13.46	0.17
<b>4500.0</b>	44.73	13.633	0.16
<b>4600.0</b>	45.293	13.805	0.16
<b>4700.0</b>	45.852	13.975	0.16
<b>4800.0</b>	46.405	14.144	0.16
<b>4900.0</b>	46.955	14.311	0.16
<b>5000.0</b>	47.5	14.477	0.15
<b>6000.0</b>	52.747	16.077	0.14
<b>8000.0</b>	62.37	19.01	0.12
<b>8800.0</b>	65.974	20.108	0.11

# FSJ1RK-50A

<b>10000.0</b>	71.173	21.693	0.1
<b>12000.0</b>	79.393	24.198	0.09
<b>14000.0</b>	87.172	26.569	0.08
<b>15800.0</b>	93.872	28.611	0.08
<b>16000.0</b>	94.601	28.833	0.08
<b>18000.0</b>	101.745	31.01	0.07

## Material Specifications

<b>Dielectric Material</b>	Foam PE
<b>Jacket Material</b>	Non-halogenated, fire retardant polyolefin
<b>Inner Conductor Material</b>	Copper-clad aluminum wire
<b>Outer Conductor Material</b>	Corrugated copper

## Mechanical Specifications

<b>Minimum Bend Radius, multiple Bends</b>	25.4 mm   1 in
<b>Minimum Bend Radius, single Bend</b>	25.4 mm   1 in
<b>Number of Bends, minimum</b>	15
<b>Number of Bends, typical</b>	20
<b>Tensile Strength</b>	68 kg   149.914 lb
<b>Bending Moment</b>	0.7 N-m   6.196 in lb
<b>Flat Plate Crush Strength</b>	1.8 kg/mm   100.795 lb/in

## Environmental Specifications

<b>Installation temperature</b>	-40 °C to +60 °C (-40 °F to +140 °F)
<b>Operating Temperature</b>	-40 °C to +60 °C (-40 °F to +140 °F)
<b>Storage Temperature</b>	-40 °C to +60 °C (-40 °F to +140 °F)
<b>Attenuation, Ambient Temperature</b>	68 °F   20 °C
<b>Average Power, Ambient Temperature</b>	104 °F   40 °C
<b>Average Power, Inner Conductor Temperature</b>	212 °F   100 °C
<b>EN50575 CPR Cable EuroClass Fire Performance</b>	B2ca
<b>EN50575 CPR Cable EuroClass Smoke Rating</b>	s1a
<b>EN50575 CPR Cable EuroClass Droplets Rating</b>	d0
<b>EN50575 CPR Cable EuroClass Acidity Rating</b>	a1

# FSJ1RK-50A

---

**Fire Retardancy Test Method**

IEC 60332-1-2 | IEC 60332-3-24 | NFPA 130-2010 | UL 1666/CATVR /CMR | UL 1685

**Smoke Index Test Method**

IEC 61034

**Toxicity Index Test Method**

IEC 60754-1 | IEC 60754-2

## Packaging and Weights

**Cable weight**

0.07 kg/m | 0.047 lb/ft

## Regulatory Compliance/Certifications

<b>Agency</b>	<b>Classification</b>
CENELEC	EN 50575 compliant, Declaration of Performance (DoP) available
CHINA-ROHS	Below maximum concentration value
ISO 9001:2015	Designed, manufactured and/or distributed under this quality management system
REACH-SVHC	Compliant as per SVHC revision on <a href="http://www.commscope.com/ProductCompliance">www.commscope.com/ProductCompliance</a>
ROHS	Compliant
UK-ROHS	Compliant
UL/ETL Certification	Compliant

