

4

3

2

1

- 1.0 GENERAL NOTES
  - 1.1 ALL METRIC DIMENSIONS ARE IN BRACKETS [X.XX]
  - 1.2 FOR PATENT INFO: <https://www.cs-pat.com>
- 2.0 DESIGN NOTES
  - 2.1 ANY HAZARDS OR OBSTRUCTIONS TO THE CLIMBING FACILITY AND SAFETY CLIMB MUST BE IDENTIFIED PRIOR TO INSTALLING THE APPURTENANCE. ADDITIONAL PRODUCTS MAY BE REQUIRED TO MAINTAIN THE INTEGRITY OF THE SAFETY CLIMB. DURING INSTALLATION, TEMPORARY AND/OR PERMANENT PRECAUTIONARY MEASURES SHOULD BE TAKEN TO PRESERVE THE CLIMBING FACILITY AND/OR SAFETY CLIMB.
  - 2.2 UP TO 5.0° TAPER AVAILABLE ON MODELS THAT SUPPORT ADJUSTMENT.
  - 2.3 FACE WIDTH MUST BE GREATER THAN OR EQUAL TO 32.5" TO MEET THE APEX DISTANCE OF ANTENNA TO ANTENNA >24".
- 3.0 MANUFACTURING/SPECIAL REQUIREMENTS
  - 3.1 TIGHTEN ALL BOLTS SECURING FLAT PLATES BY THE TURN-OF-NUT METHOD. TIGHTEN ALL U-BOLTS USING TURN-OF-NUT METHOD WITH ATTENTION TO LEAVE EQUAL DISTANCE AND EQUAL FORCE ON EACH LEG OF THE U-BOLT.
- 4.0 TEST
- 5.0 PACKAGING
  - 5.1 PACKAGING SHALL MEET COMMSCOPE REQUIREMENTS PER DOCUMENT IS-PL-3005.
  - 5.2 PRINTED DOCUMENT TO BE PLACED INSIDE POLYBAG AND THEN IN SHIPPING CONTAINER.
  - 5.3 EXTRA HARDWARE MAY BE SUPPLIED, BAGGED AND SHIPPED.

REVISIONS			
REV.	DESCRIPTION	DATE	APPROVED
A	INITIAL RELEASE	JL1183 05FEB24	CB1094 40188553CMO
B	SADDLE MOUNT CHANGED TO G23	YMENG 13JUN24	BA1025 40197994CMO
C	SFG2292-00(ITEM 2) WAS SFG2278; ADDED SHEET 5 V-ARM VIEW	JL1183 25NOV24	YZ1080 40209215CMO

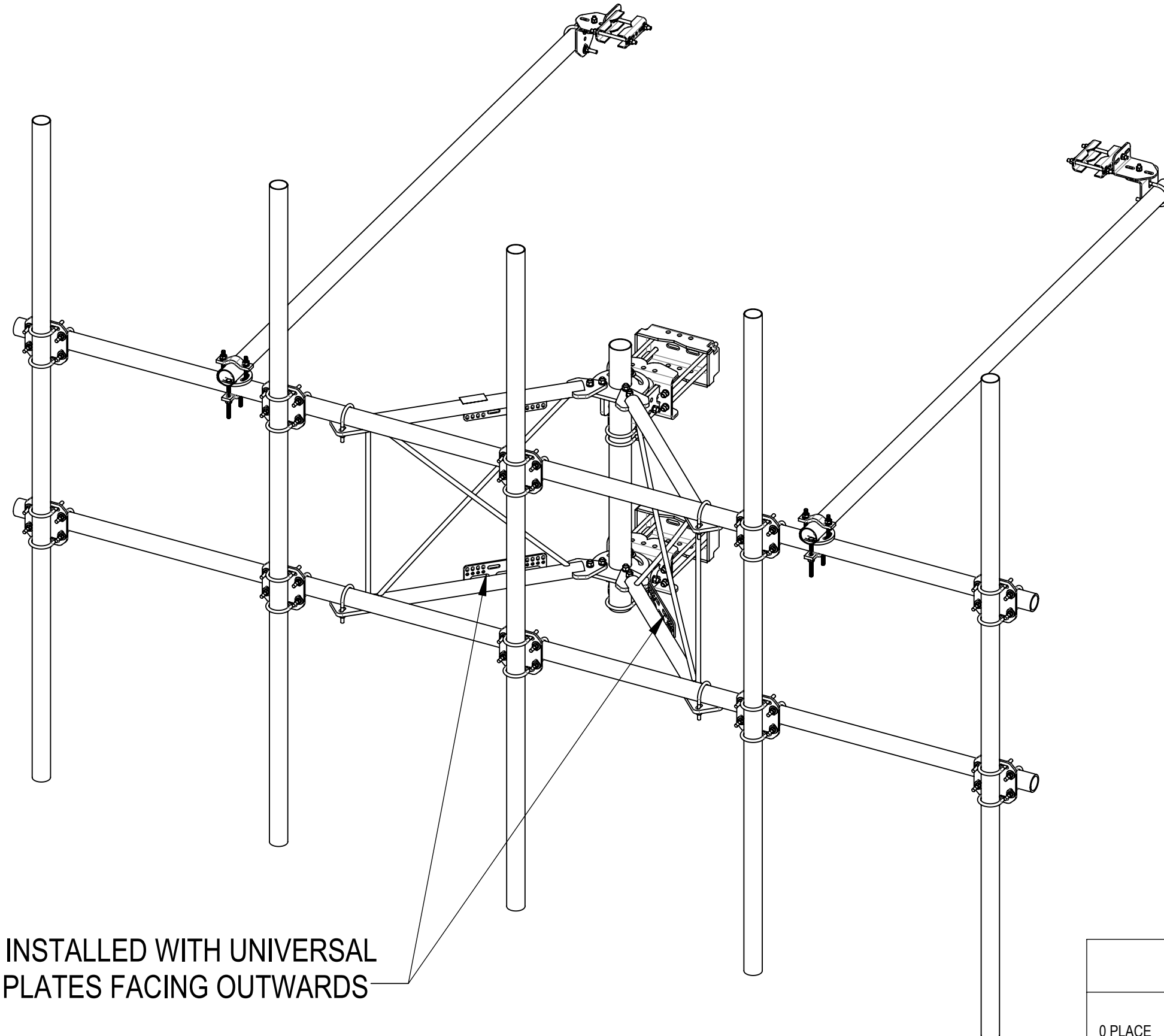

SHOULD BE INSTALLED WITH UNIVERSAL INTERFACE PLATES FACING OUTWARDS

<b>COMMSCOPE, INC. OF NORTH CAROLINA</b>										
TOLERANCES					SAP MATERIAL MASTER					
0 PLACE .X[X] ± 0.25[6.3]		2 PLACE .XX[X] ± 0.06[1.5]			<b>SFG22HDX-15-5-WLL</b>					
1 PLACE .X[X] ± 0.12[3.0]		ANGLES ± 2°								
FINISH					MATERIAL					
UNLESS OTHERWISE SPECIFIED DIMENSIONS ARE IN INCHES INTERPRET PER ANSI Y 14.5M-1994	NAME		DATE		<b>SF, 15',(5)2.88"X120"-PIPES-PIM-SPACED</b>					
	CE	JL1183	05FEB24							
	RW	JL1183	11/28/2024							
	AD	YZ1080	12/02/2024							
	RE	YMENG	12/24/2024							
ECN 40209215CMO					SCALE		DOCUMENT NO.			
					<b>1:18</b>		<b>SFG22HDX-15-5-WLL</b>			
SIZE		Auth Group		INSL		MODEL			DRAWING	
<b>C</b>						VERSION			STATUS	
						02			RE	
						RE			B	
						02			RE	
						C			C	
SHEET										
1 OF 7										

DENSITY		lbs/in <sup>3</sup>
MASS	854.64	lbs
VOLUME	3016.42	in <sup>3</sup>
SURFACE AREA	31568.69	in <sup>2</sup>
HEIGHT	120"	
LENGTH	180"	
WIDTH	120"	

4

3

2

1

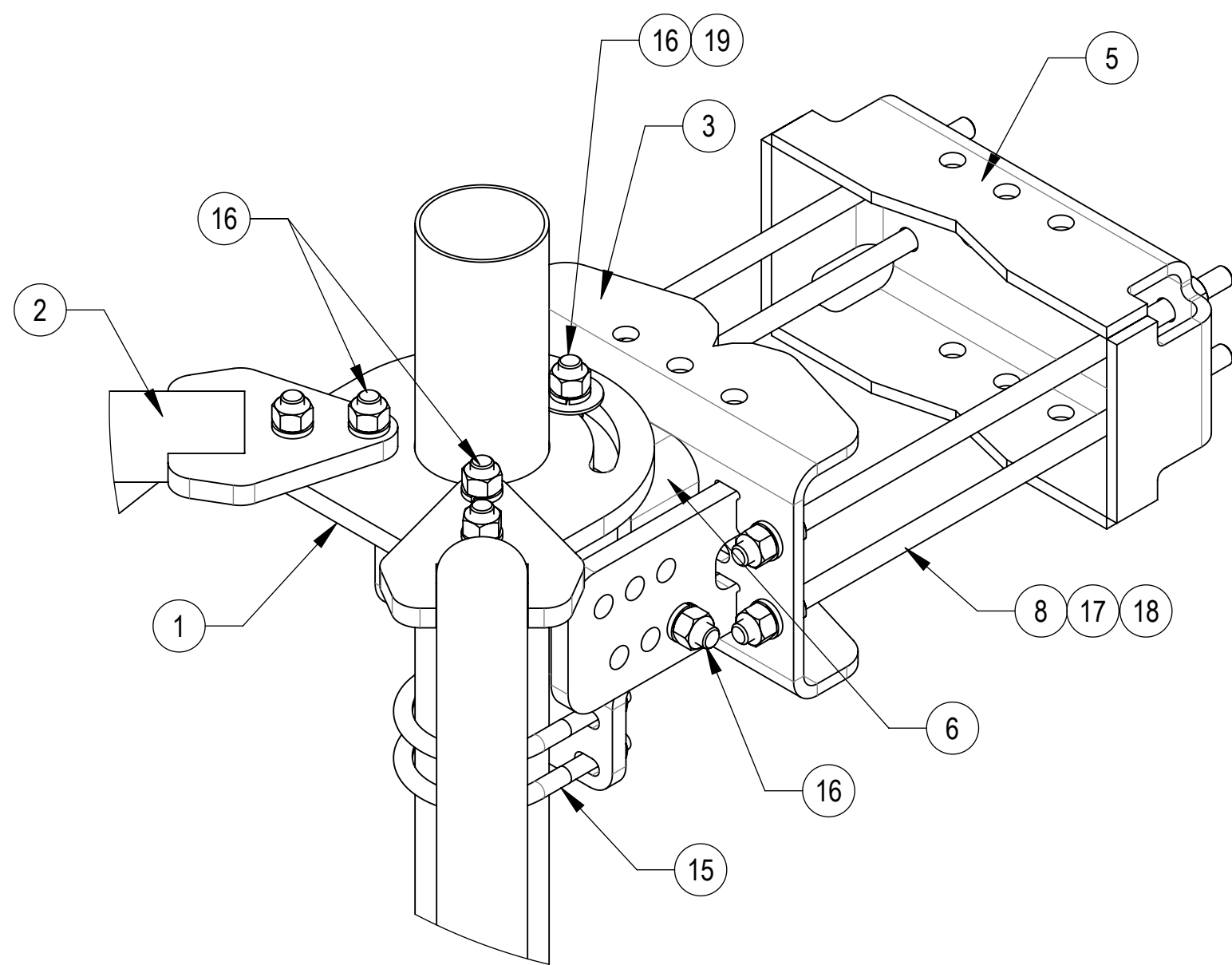

**DETAIL B**  
SCALE 1 : 4

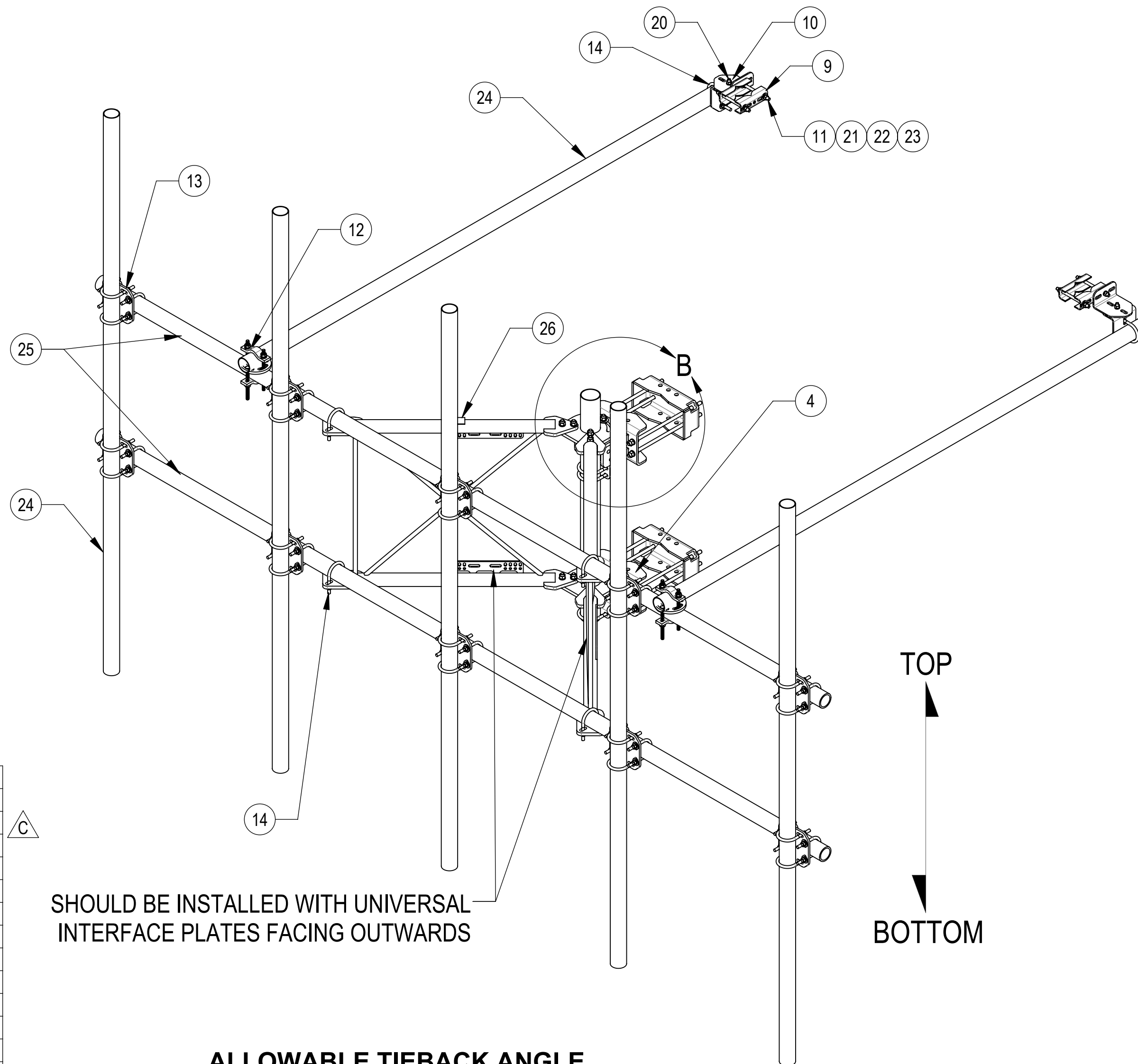

SHOULD BE INSTALLED WITH UNIVERSAL  
INTERFACE PLATES FACING OUTWARDS

**ALLOWABLE TIEBACK ANGLE**

± 15 DEGREES VERTICAL  
± 25 DEGREES HORIZONTAL

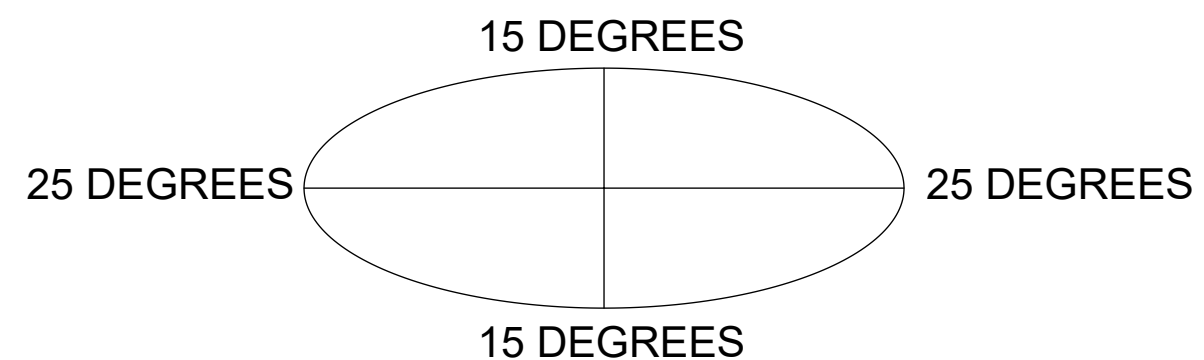

COMPONENT PART NUMBERS PROVIDED FOR ASSEMBLY PURPOSES;  
INDIVIDUAL COMPONENTS MAY BE SHIPPED AS PARTS WITHIN AN INCLUDED KIT.

ITEM	PART NO.	DESCRIPTION	QTY.	WEIGHT	NOTE NO.
1	SFG2270	BACK VERTICAL ARM MOUNT	1	36.96 LBS	
2	SFG2292-00	WELDMNT, V-ARM, SECTOR FRAME 22	2	49.69 LBS	
3	SFG2380	WELDMNT, HD, TOP TAPER BRACKET	1	22.78 LBS	
4	SFG2381	WELDMNT, HD, LOWER TOWER LEG BRACKET	1	17.42 LBS	
5	SFG2289	G2 RRU BACK CLAMP, HD	2	18.65 LBS	
6	SFG2386	WELDMNT, SFG2 AZIMUTH BRACKET	1	10.07 LBS	
7	SFG2397-00	WELDMNT, G23 AZIMUTH BRACKET	1	7.94 LBS	
8	MT-382-18	5/8" X 18" THREADED ROD	8	1.43 LBS	
9	SAB01	FORMED CLAMP	4	1.35 LBS	
10	XAU01	ANGLE, CROSSOVER, 1.9-3.5" X 1.9-3.5" OD	4	2.98 LBS	
11	MT-379-8	1/2" X 8" GALV THREADED ROD	4	0.45 LBS	
12	XP-R	CROSSOVER PLATE, ROUND, UP TO 3.5" OD	2	6.20 LBS	
13	XP-2525	CROSSOVER PLATE KIT, 2-7/8 OD X 2-7/8 OD	10	8.37 LBS	
14	GUB-4352	1/2" X 3" X 5-1/4" GALV U-BOLT	6	0.71 LBS	
15	GUB-4355	1/2" X 3-5/8" X 5" GALV U-BOLT	3	0.71 LBS	
16	GB-05225	5/8" X 2-1/4" GALV BOLT KIT	14	0.28 LBS	
17	GN-05	5/8" GALV HEX NUT	24	0.08 LBS	
18	GWL-05	5/8" GALV LOCK WASHER	16	0.03 LBS	
19	GWF-05	5/8" GALV FLAT WASHER, 1.7OD	2	0.06 LBS	
20	GB-04145	1/2" X 1-1/2" GALV BOLT KIT	2	0.13 LBS	
21	GN-04	1/2" GALV HEX NUT	10	0.04 LBS	
22	GWL-04	1/2" GALV LOCK WASHER	10	0.01 LBS	
23	GWF-04	1/2" GALV FLAT WASHER	8	0.04 LBS	
24	MT546120120	PIPE, 2.875"OD X 120"	7	35.44 LBS	
25	MT546180276	PIPE, 2.875"OD X 180"	2	115.33 LBS	
26	SFG2255	LABEL, SFG22HDX	1	0.04 LBS	

COMMSCOPE, INC. OF NORTH CAROLINA

TITLE  
SF, 15', (5) 2.88" X 120" - PIPES - PIM-SPACED

SIZE **C** SCALE **1:16** DOCUMENT NO. **SFG22HDX-15-5-WLL**

DRAWING			SHEET 2 OF 7
VERSION	STATUS	REVISION	
02	RE	C	

4

3

2

1

TIEBACK MUST BE CONNECTED TO A RIGID MEMBER THAT PROVIDES ADEQUATE SUPPORT WITHIN THE LIMITS NOTED IN THE TIEBACK ANGLE RANGE DETAIL. UNLESS APPROVED BY ENGINEER OF RECORD. SPINE STEM OF NEIGHBORING MOUNT IS ACCEPTABLE.

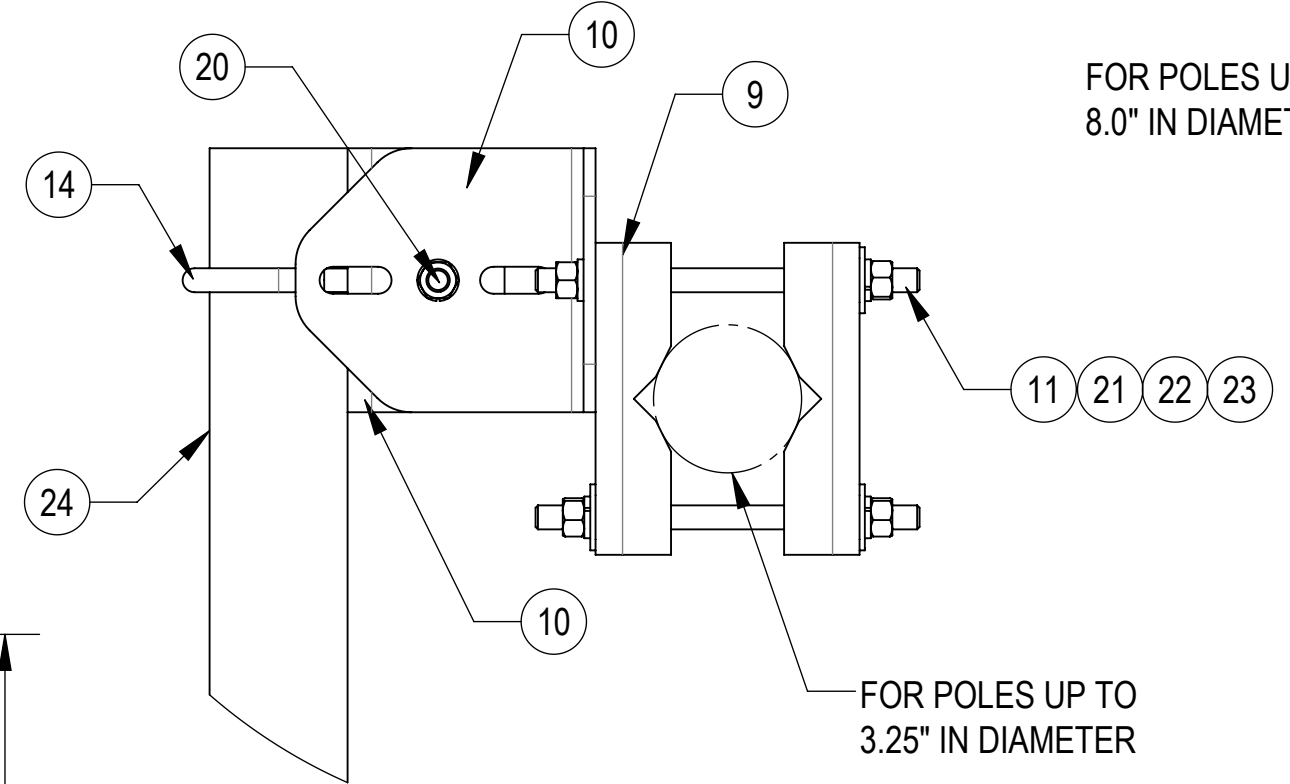
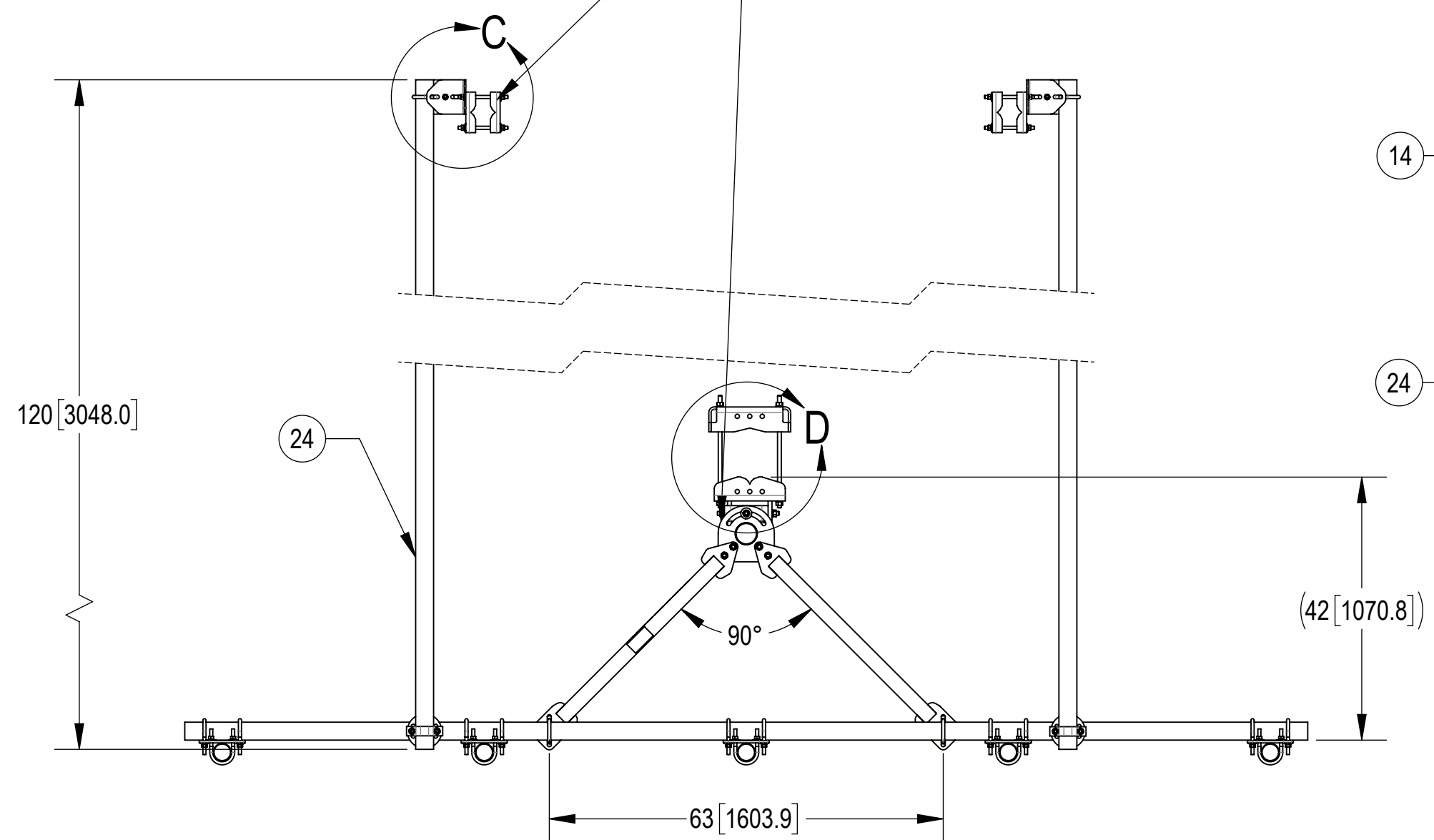

DETAIL C  
SCALE 1:4

FOR POLES UP TO 8.0" IN DIAMETER

FOR POLES UP TO 3.25" IN DIAMETER

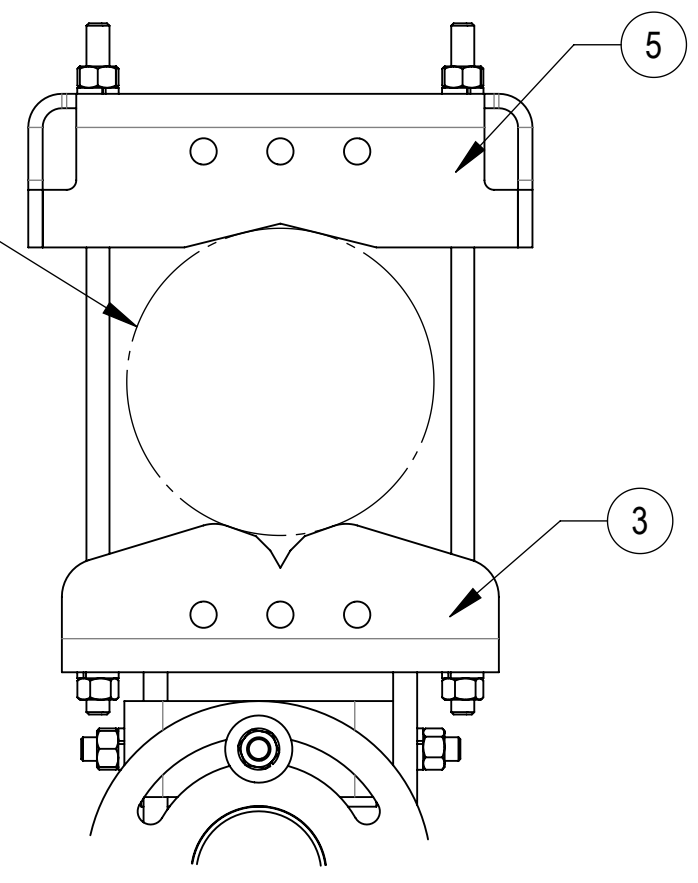

DETAIL D  
SCALE 1:5

**ALLOWABLE TIEBACK ANGLE**  
± 15 DEGREES VERTICAL  
± 25 DEGREES HORIZONTAL

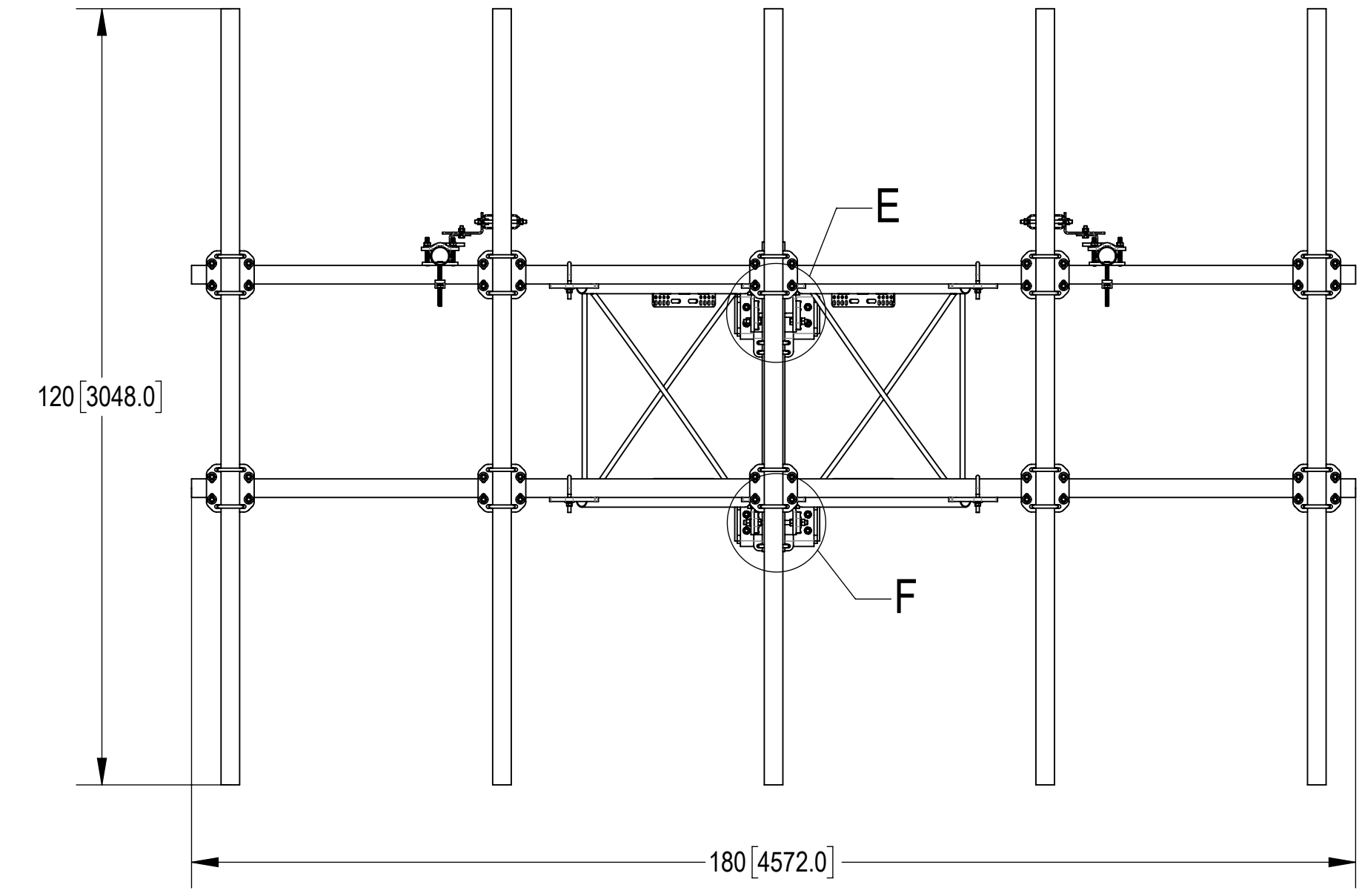
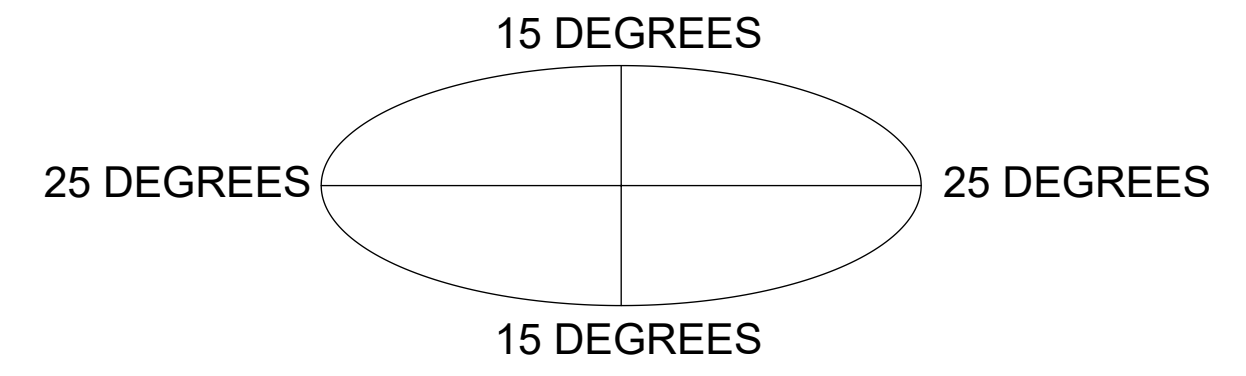

TOP  
↑  
↓  
BOTTOM

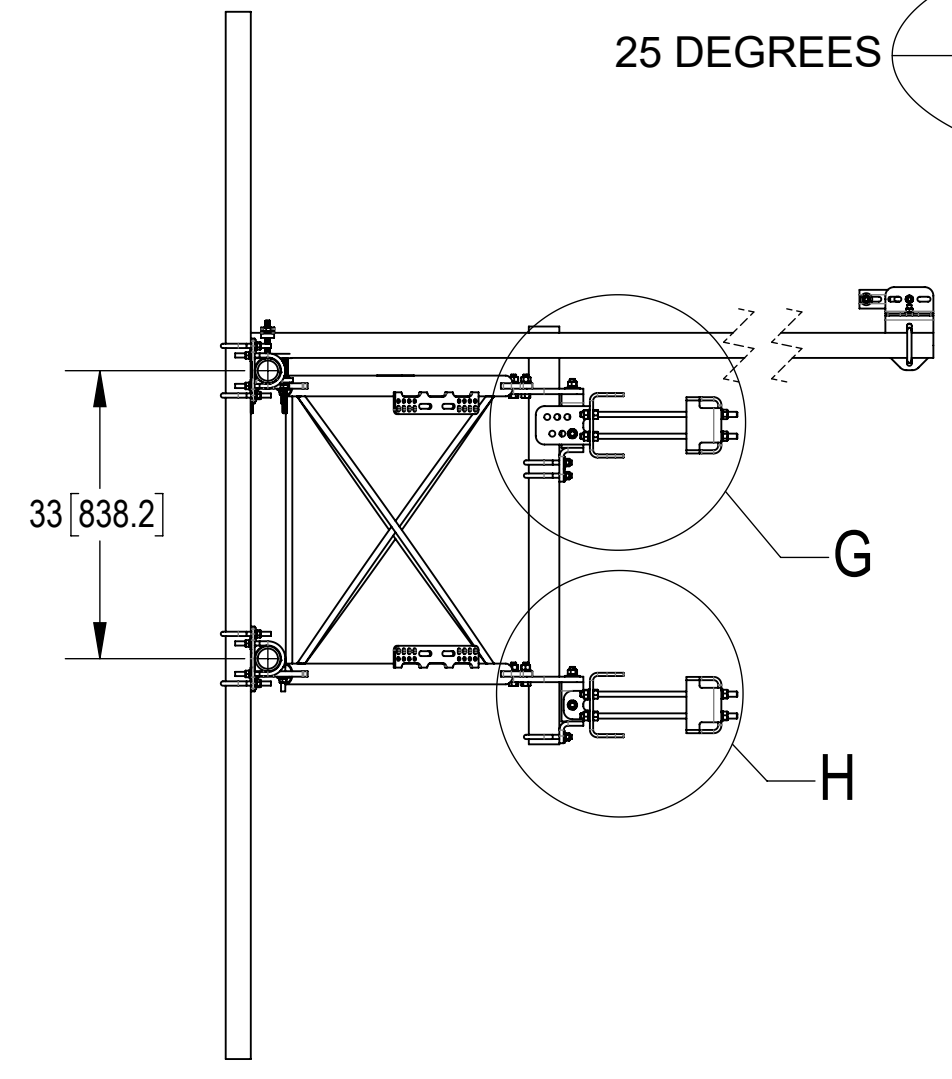

COMMSCOPE, INC. OF NORTH CAROLINA				
TITLE SF, 15', (5) 2.88" X 120" - PIPES - PIM - SPACED				
SIZE <b>C</b>	SCALE <b>1:22</b>	DOCUMENT NO. <b>SFG22HDX-15-5-WLL</b>		
		DRAWING		SHEET
		VERSION	STATUS	REVISION
		02	RE	C
				SHEET 3 OF 7

4

3

2

1

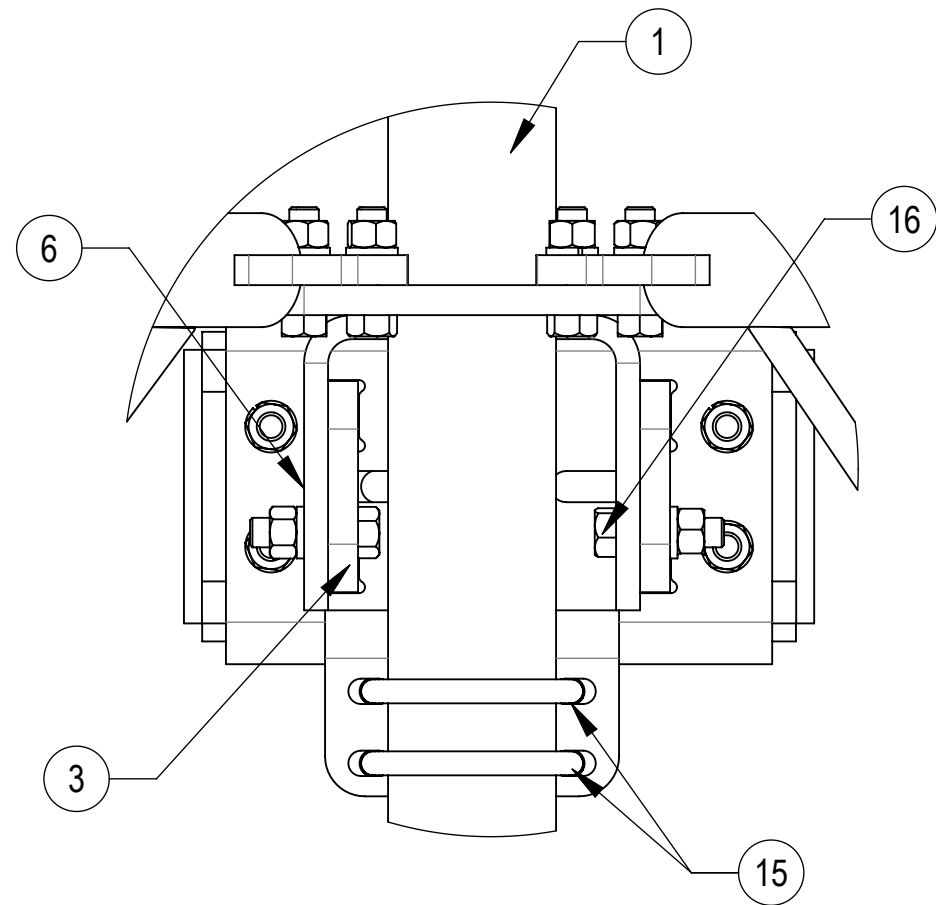

**DETAIL E**  
SCALE 1 : 4

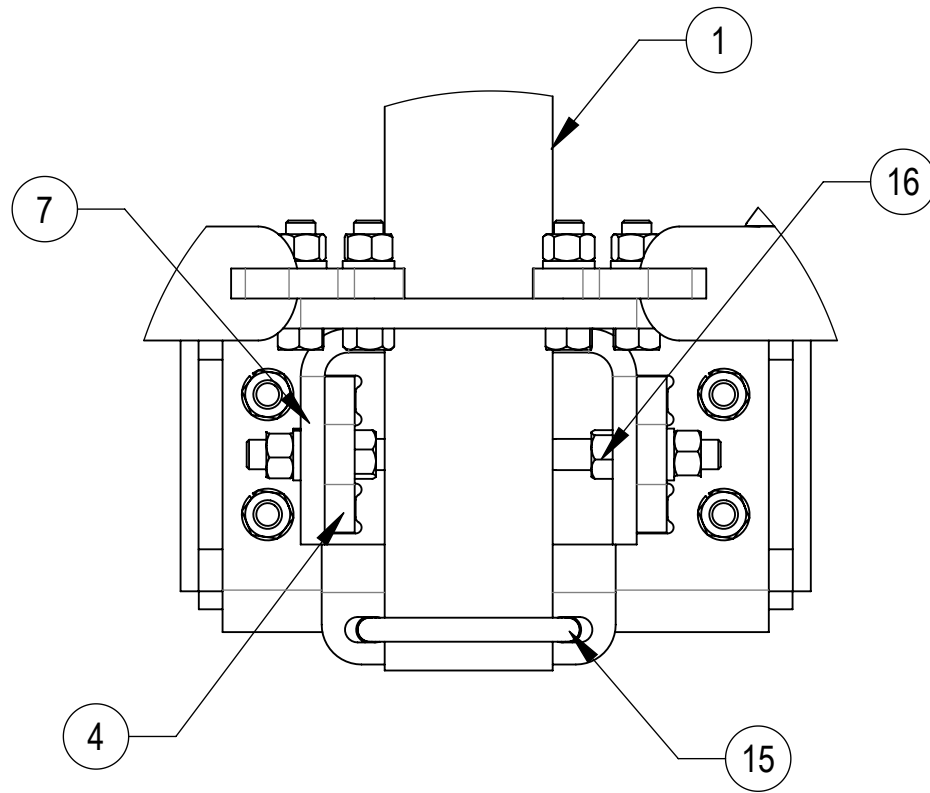

**DETAIL F**  
SCALE 1 : 4

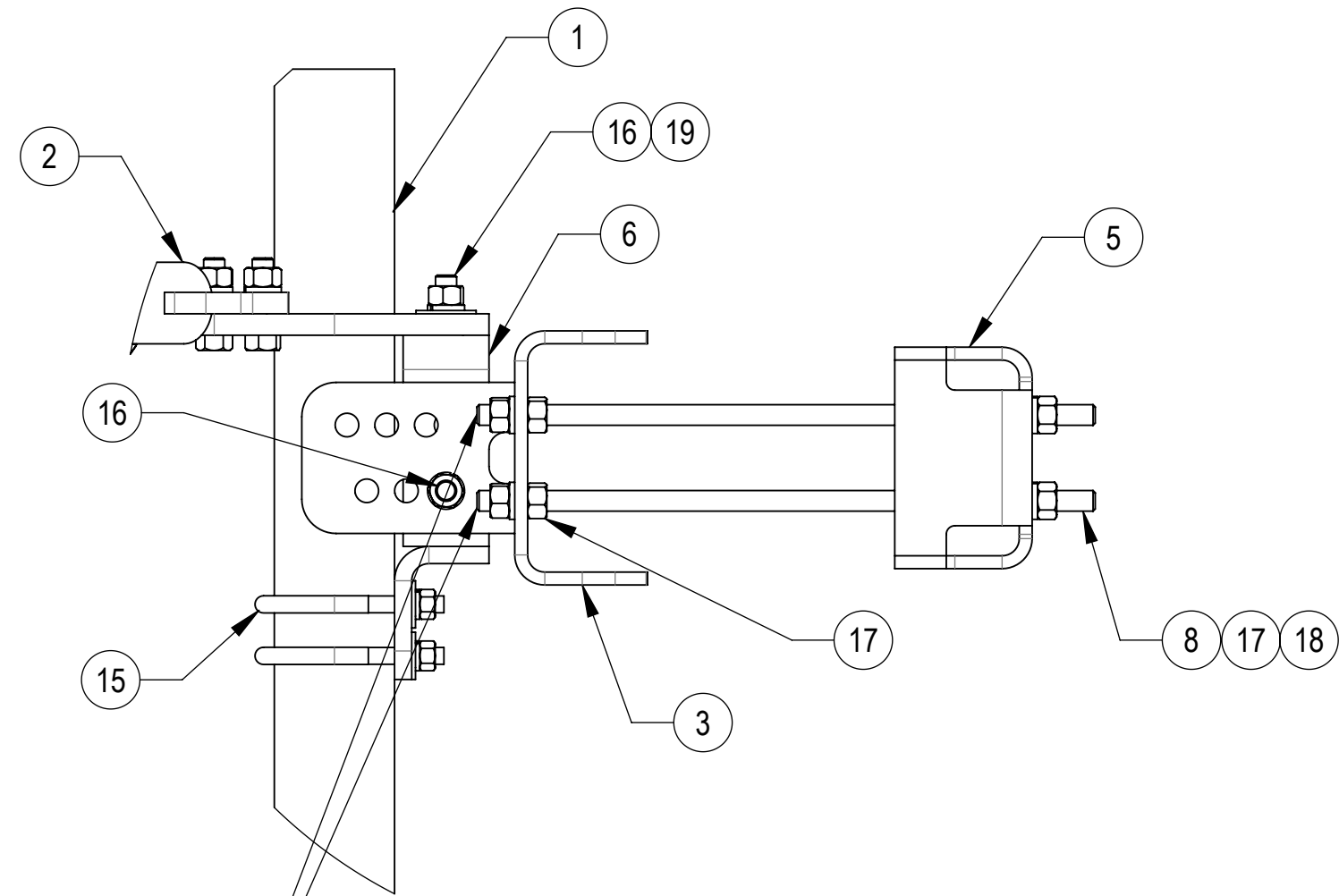

**DETAIL G**  
SCALE 1 : 5

THE THREADED ROD CAN ONLY EXPOSE 4 TO 7 THREADS ON ONE SIDE OF THE BRACKET, WHICH IS TO PREVENT INTERFERENCE WITH THE SIDE BOLTS

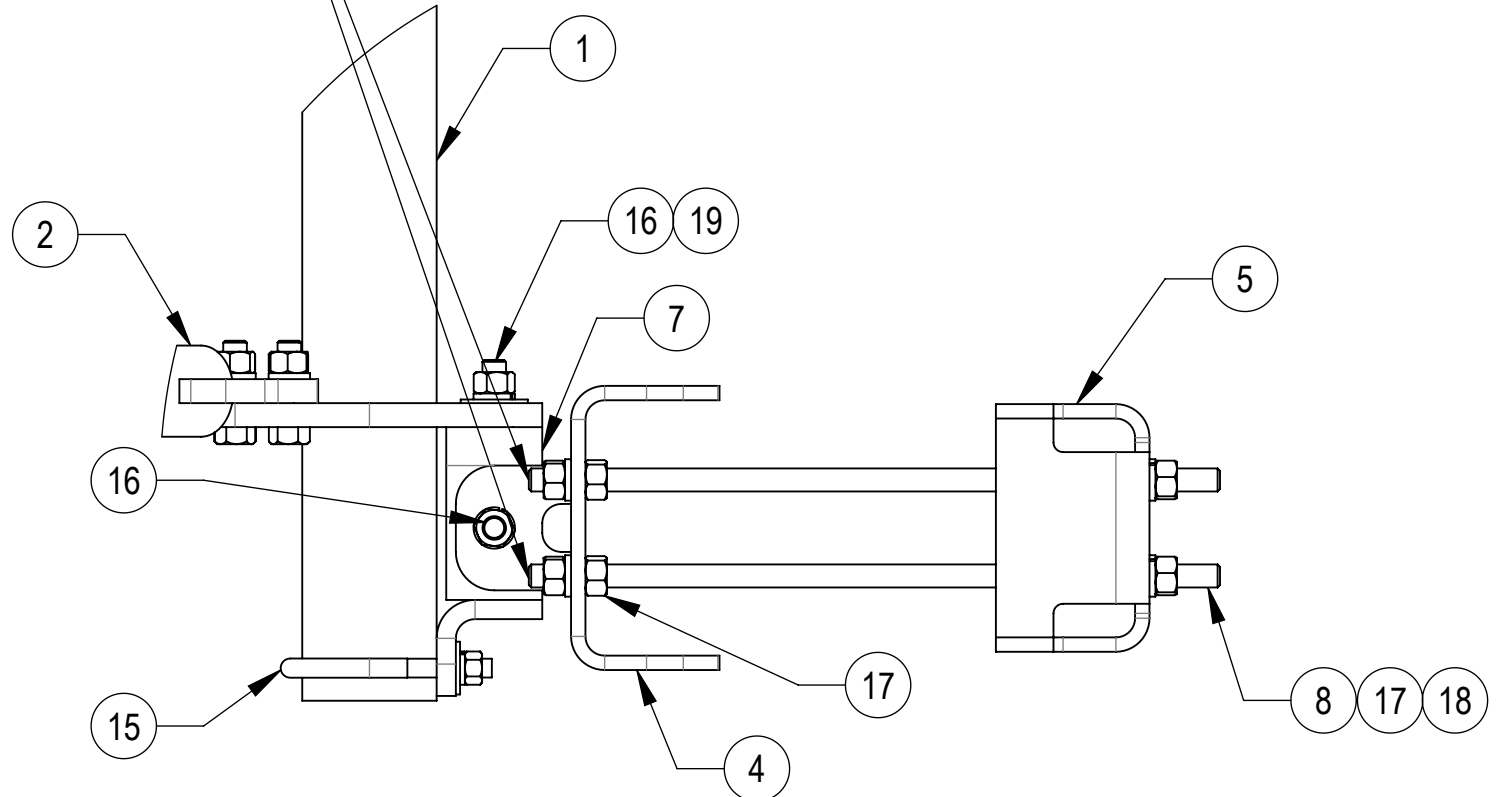

**DETAIL H**  
SCALE 1 : 5

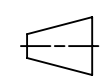
COMMSCOPE, INC. OF NORTH CAROLINA					
TITLE SF, 15', (5) 2.88" X 120" - PIPES - PIM-SPACED					
SIZE <b>C</b>	SCALE <b>1:20</b>	DOCUMENT NO. <b>SFG22HDX-15-5-WLL</b>			
 		DRAWING			SHEET 4 OF 7
		VERSION 02	STATUS RE	REVISION C	

4

3

2

1

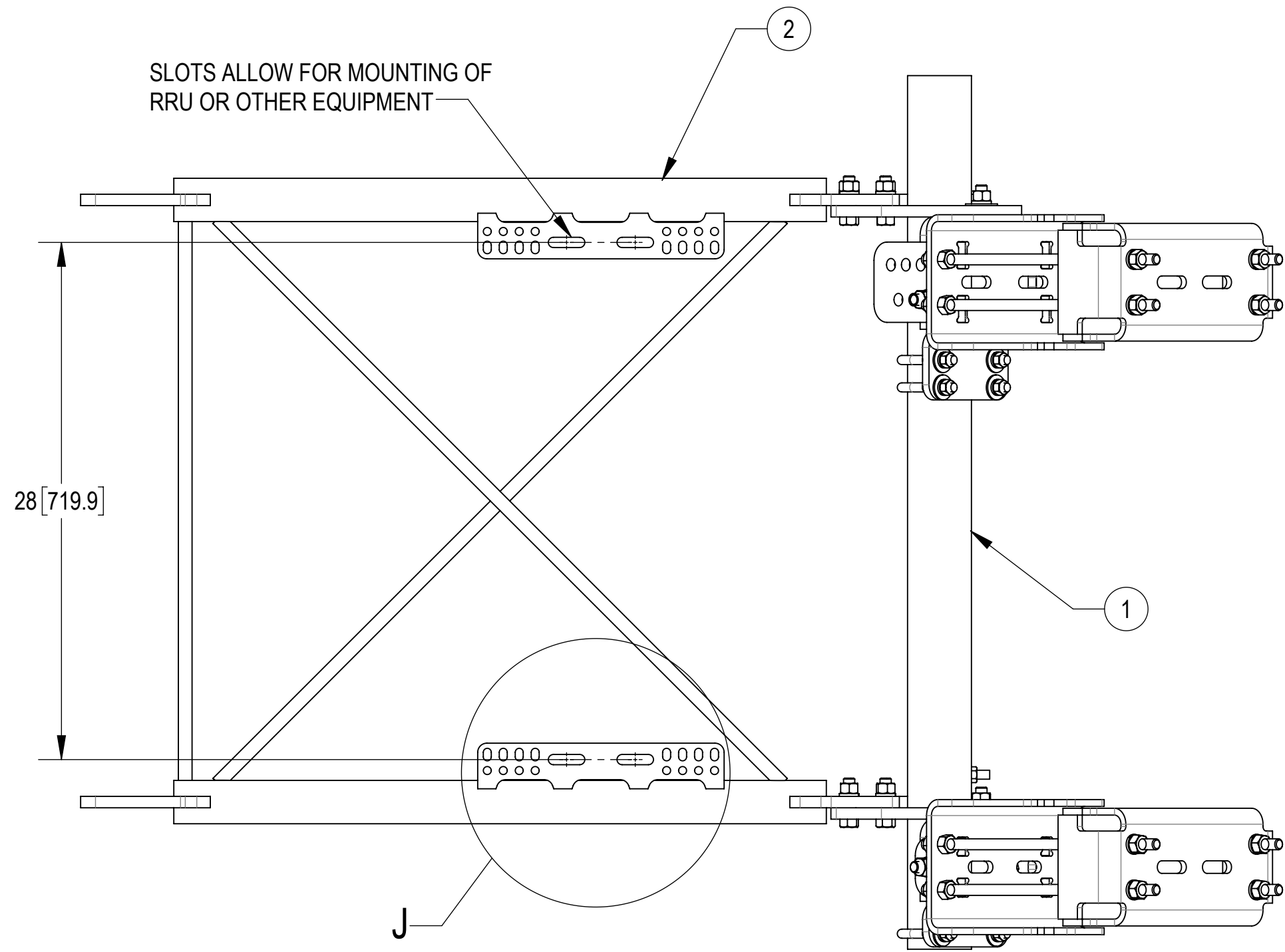

SLOTS ALLOW FOR MOUNTING OF RRU OR OTHER EQUIPMENT

28 [719.9]

J

SIDE VIEW

SLOTS ALLOW FOR MOUNTING OF RRU OR OTHER EQUIPMENT

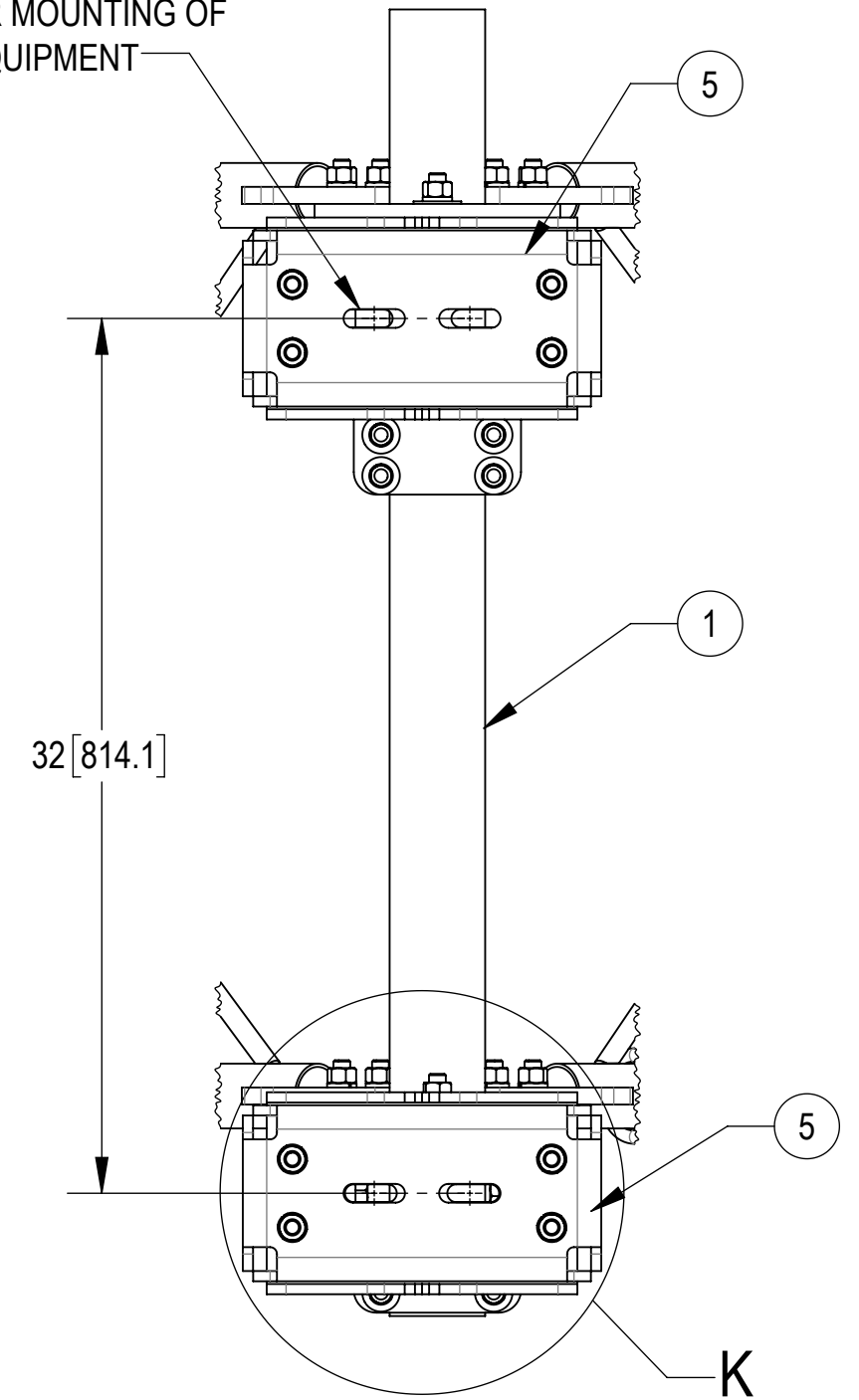

32 [814.1]

BACK CROP VIEW

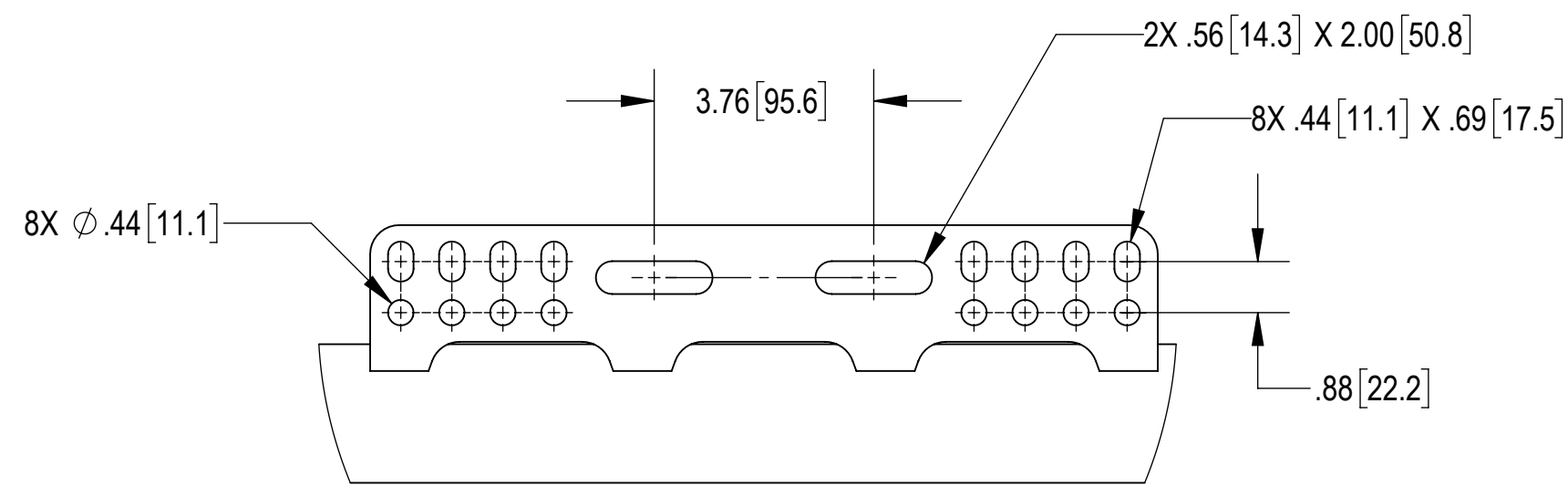

DETAIL J  
SCALE 1 : 3

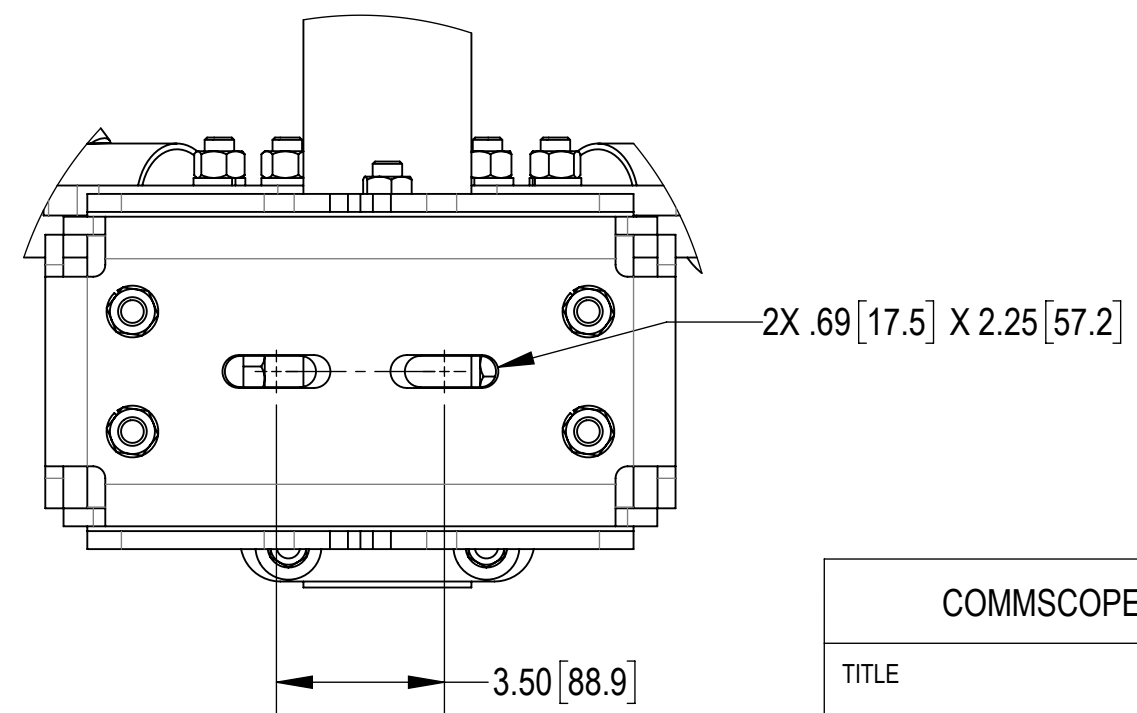

DETAIL K  
SCALE 1 : 4

COMMSCOPE, INC. OF NORTH CAROLINA				
TITLE SF, 15', (5) 2.88" X 120" - PIPES-PIM-SPACED				
SIZE <b>C</b>	SCALE <b>1:6</b>	DOCUMENT NO. <b>SFG22HDX-15-5-WLL</b>		
		DRAWING		SHEET
		VERSION	STATUS	REVISION
		02	RE	C
				SHEET 5 OF 7

4

3

2

1

ANTENNA SPACING SHOWN

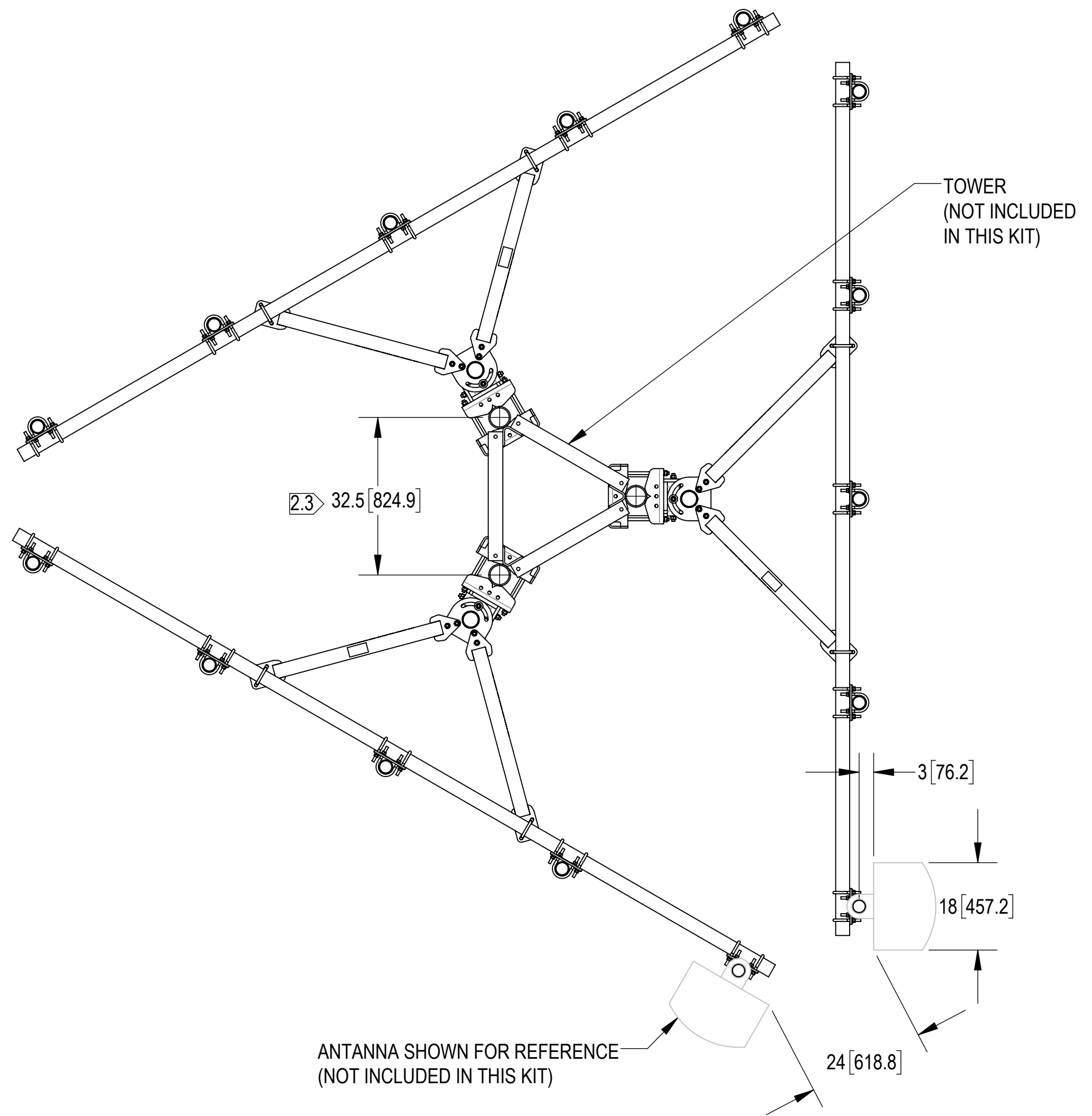
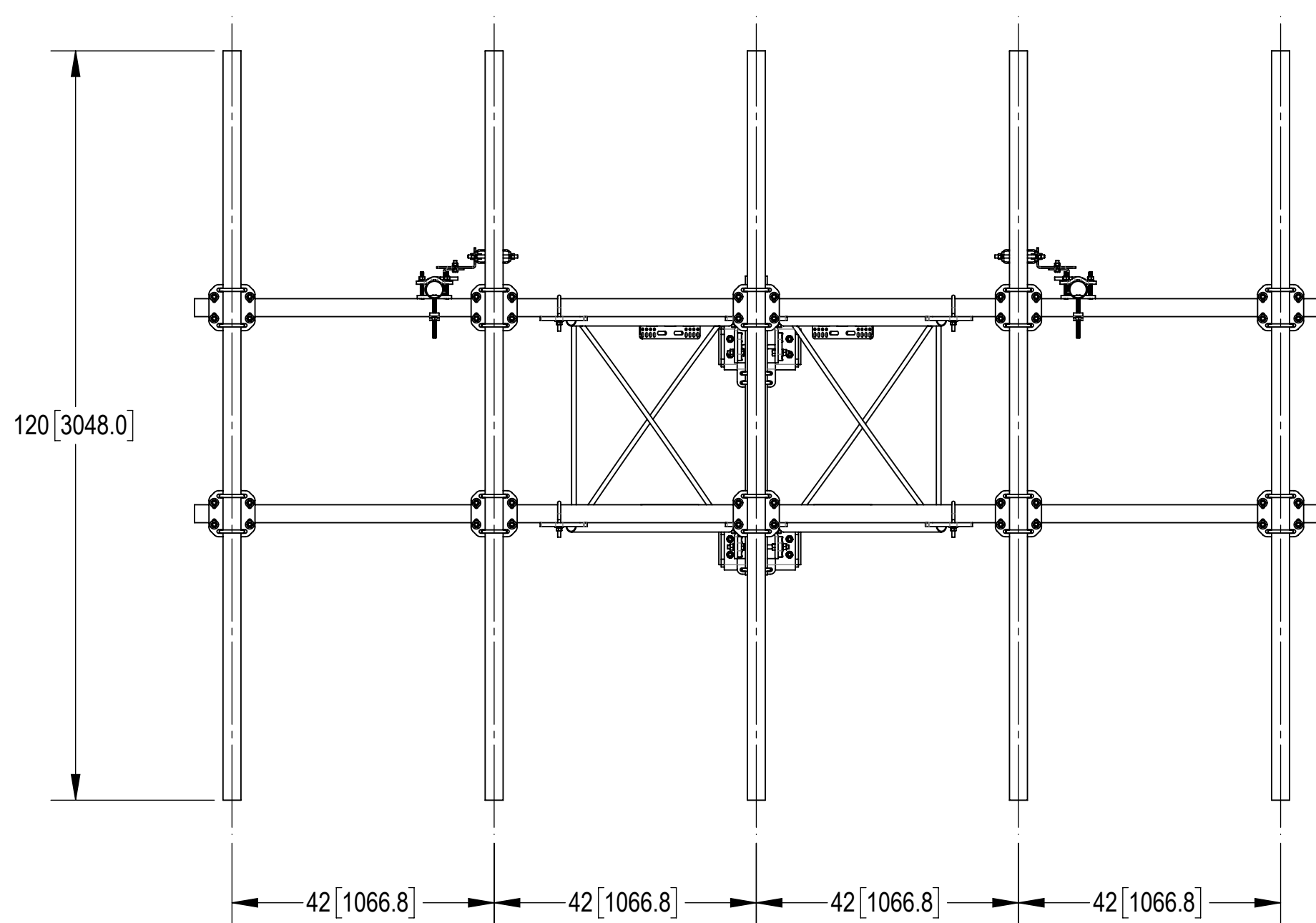
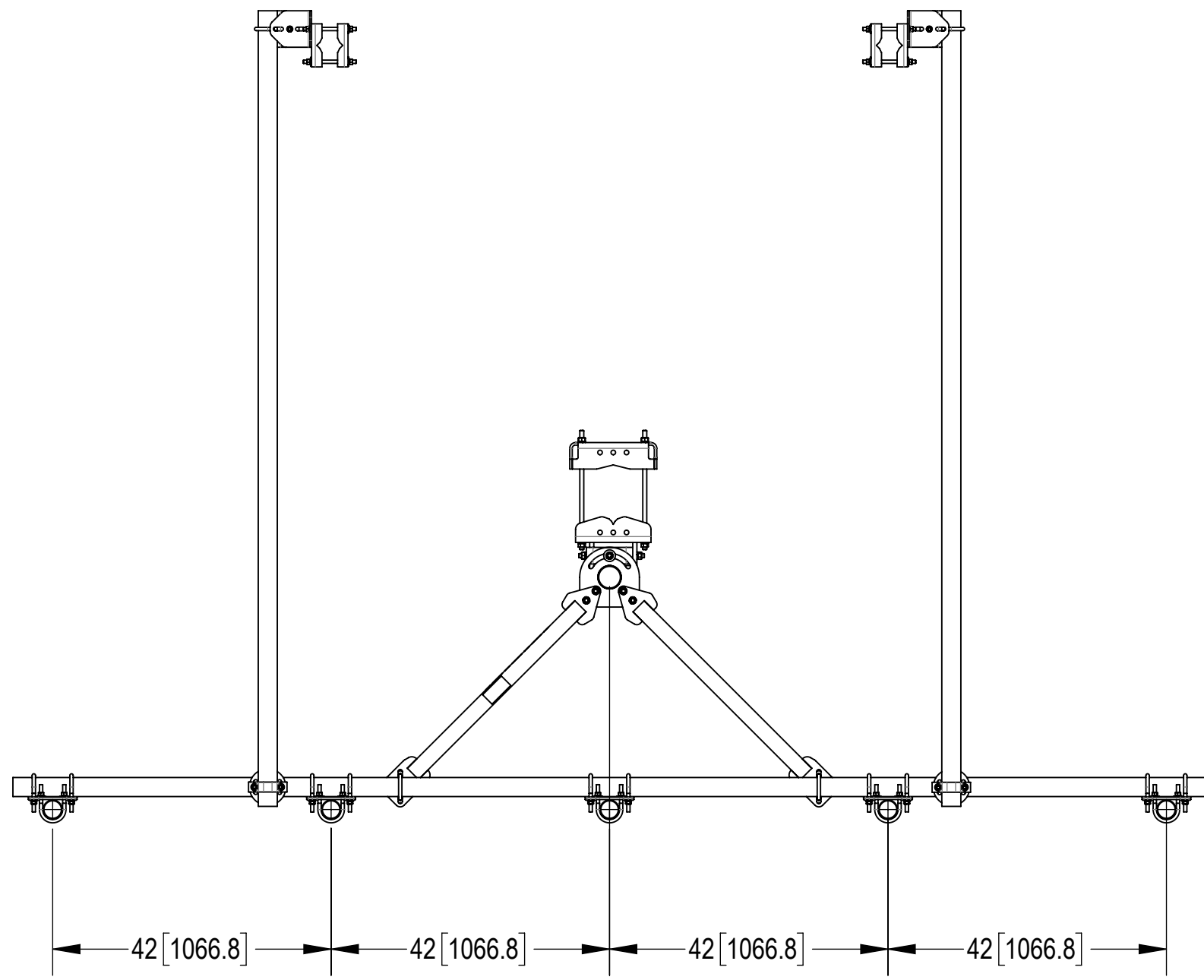

INSTALLED ON STANDARD TOWER SHOWN

COMMSCOPE, INC. OF NORTH CAROLINA				
TITLE				
SF, 15', (5) 2.88" X 120" - PIPES - PIM - SPACED				
SIZE	SCALE	DOCUMENT NO.		
C	1:22	SFG22HDX-15-5-WLL		
		DRAWING		
		VERSION	STATUS	REVISION
		02	RE	C
				SHEET
				6 OF 7

4

3

2



1

**OPTIONAL ACCESSORIES:**

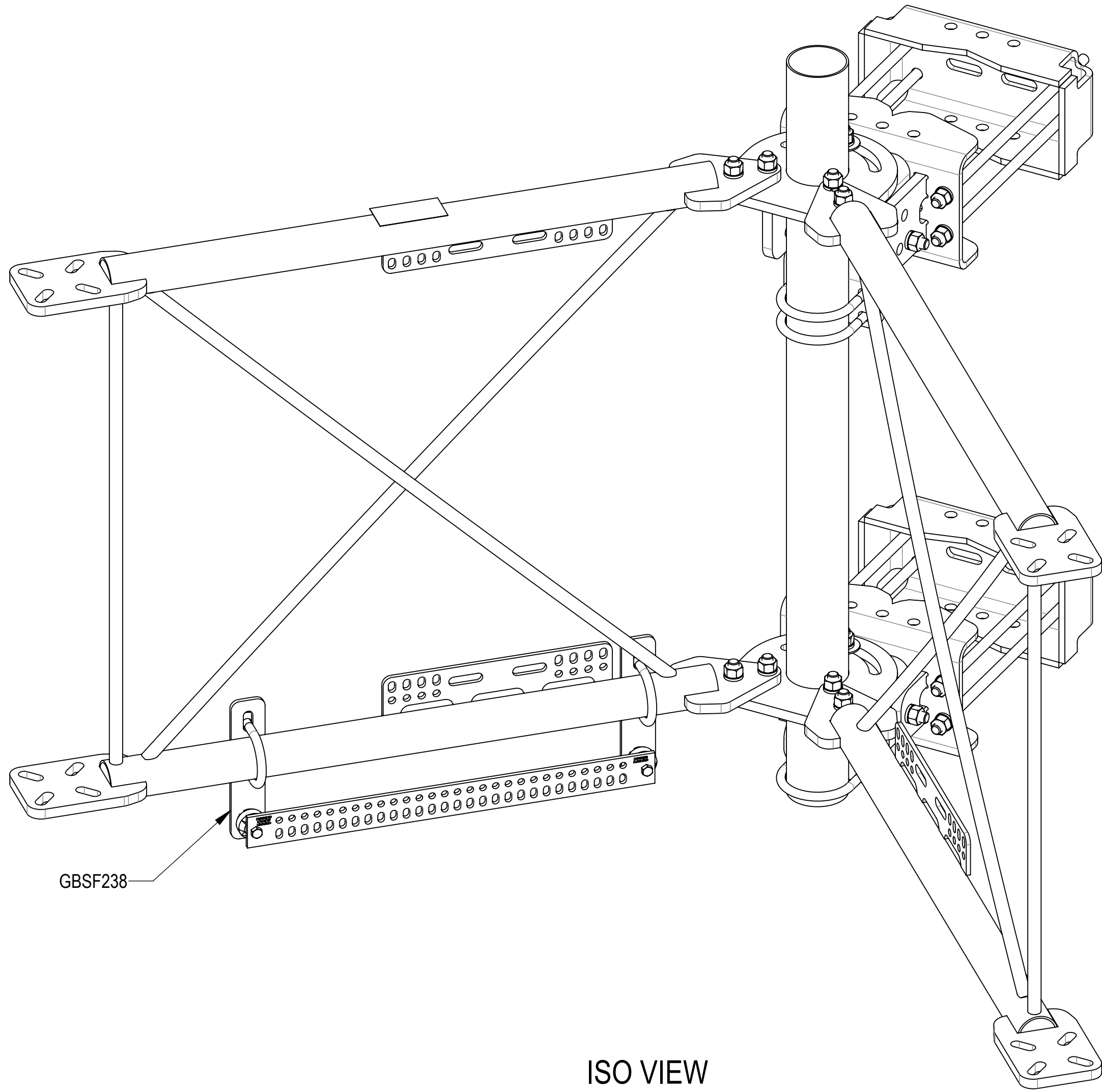
BUS BAR MOUNT KIT GBSF238 IS WELL SUITED TO BE USED SHOULD THE NEED ARISE  
NOTE THAT THIS KIT DOES NOT INCLUDE THE ISOLATORS OR BUS BAR



ISO VIEW

COMMSCOPE, INC. OF NORTH CAROLINA				
TITLE SF, 15', (5) 2.88" X 120" - PIPES - PIM-SPACED				
SIZE <b>C</b>	SCALE <b>1:6</b>	DOCUMENT NO. SFG22HDX-15-5-WLL		
 		DRAWING		SHEET
		VERSION 02	STATUS RE	REVISION C

4

3

2

1

D

D

C

C

B

B

A

A