

- 1.0 GENERAL NOTES
 1.1 ALL METRIC DIMENSIONS ARE IN BRACKETS [X.X]
 1.2 FOR PATENT INFO: <https://www.cs-pat.com>
 2.0 DESIGN NOTES
 3.0 MANUFACTURING/SPECIAL REQUIREMENTS
 3.1 TIGHTEN ALL BOLTS SECURING FLAT PLATES BY THE TURN-OF-NUT METHOD. TIGHTEN ALL U-BOLTS USING TURN-OF-NUT METHOD WITH ATTENTION TO LEAVE EQUAL DISTANCE AND EQUAL FORCE ON EACH LEG OF THE U-BOLT.
 4.0 TEST
 5.0 PACKAGING
 5.1 PACKAGING SHALL MEET COMMSCOPE REQUIREMENTS PER DOCUMENT IS-PL-3005
 5.2 PRINTED DOCUMENT TO BE PLACED INSIDE POLYBAG AND THEN IN SHIPPING CONTAINER
 5.3 EXTRA HARDWARE MAY BE SUPPLIED, BAGGED AND SHIPPED

REVISIONS			
REV.	DESCRIPTION	DATE	APPROVED
A	INITIAL RELEASE	DRR 04APR12	TP
B	UPDATED DRAWING FORMAT	LL1090 23AUG24	YC1015 40203043CMO

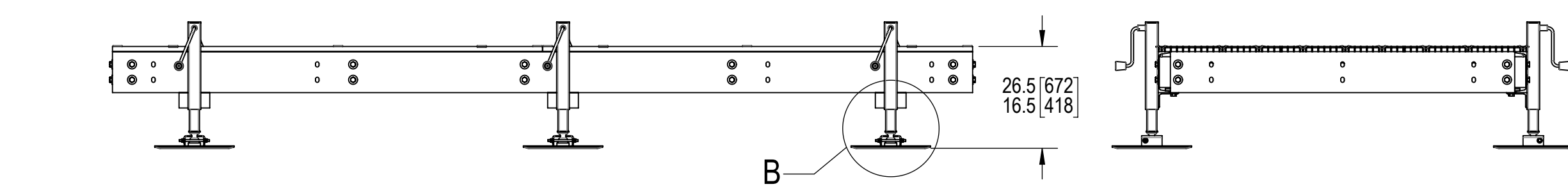
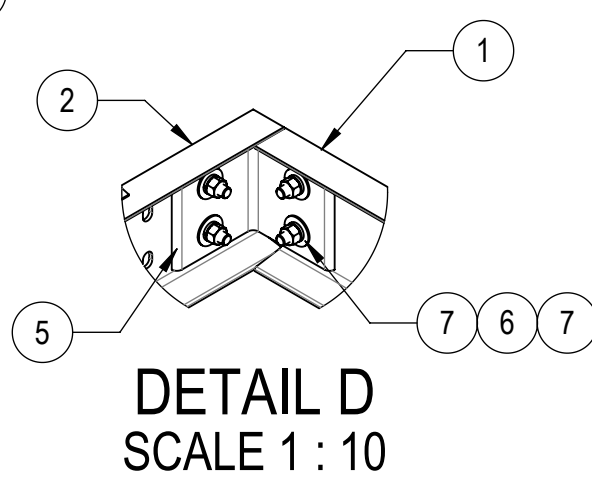
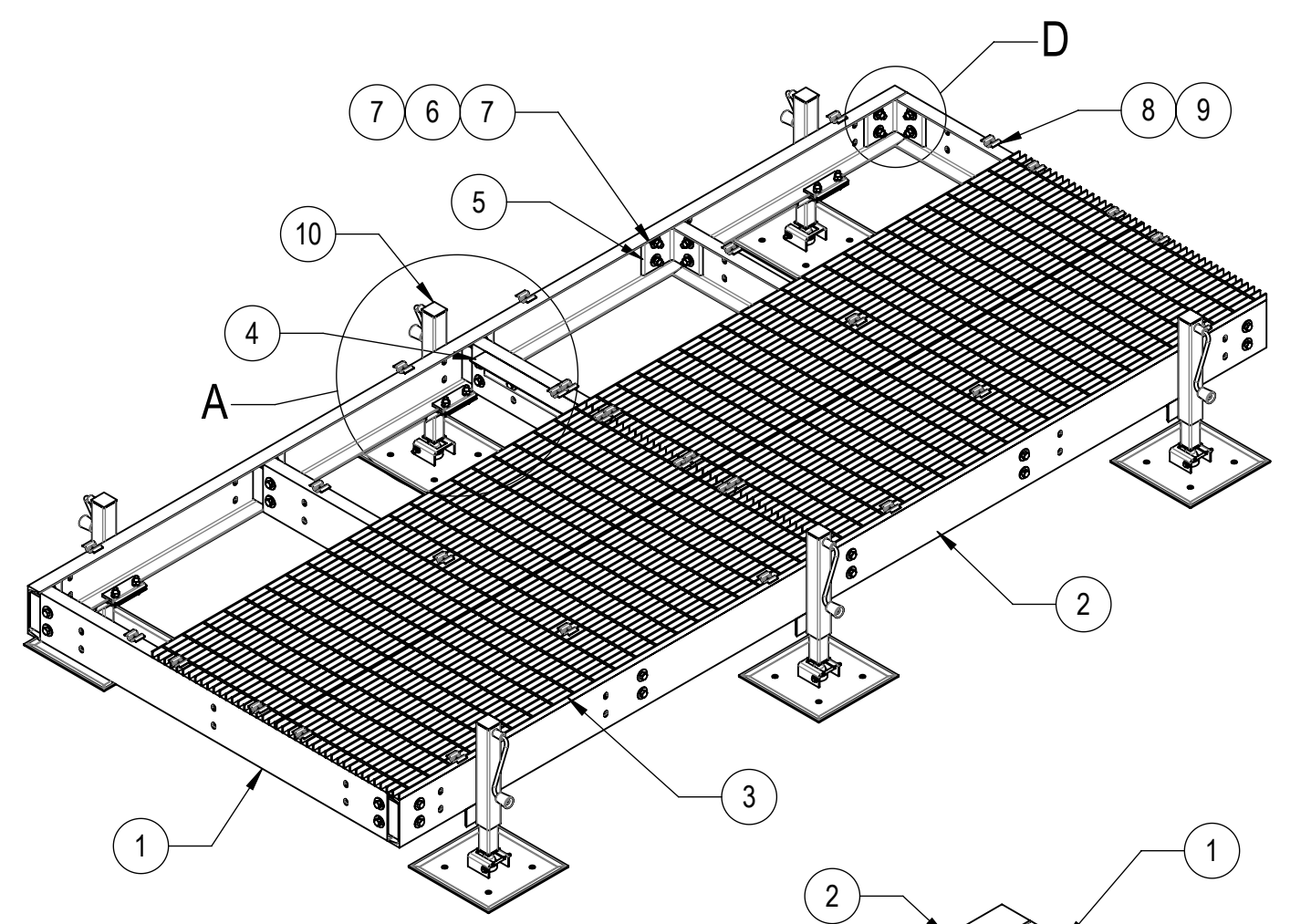
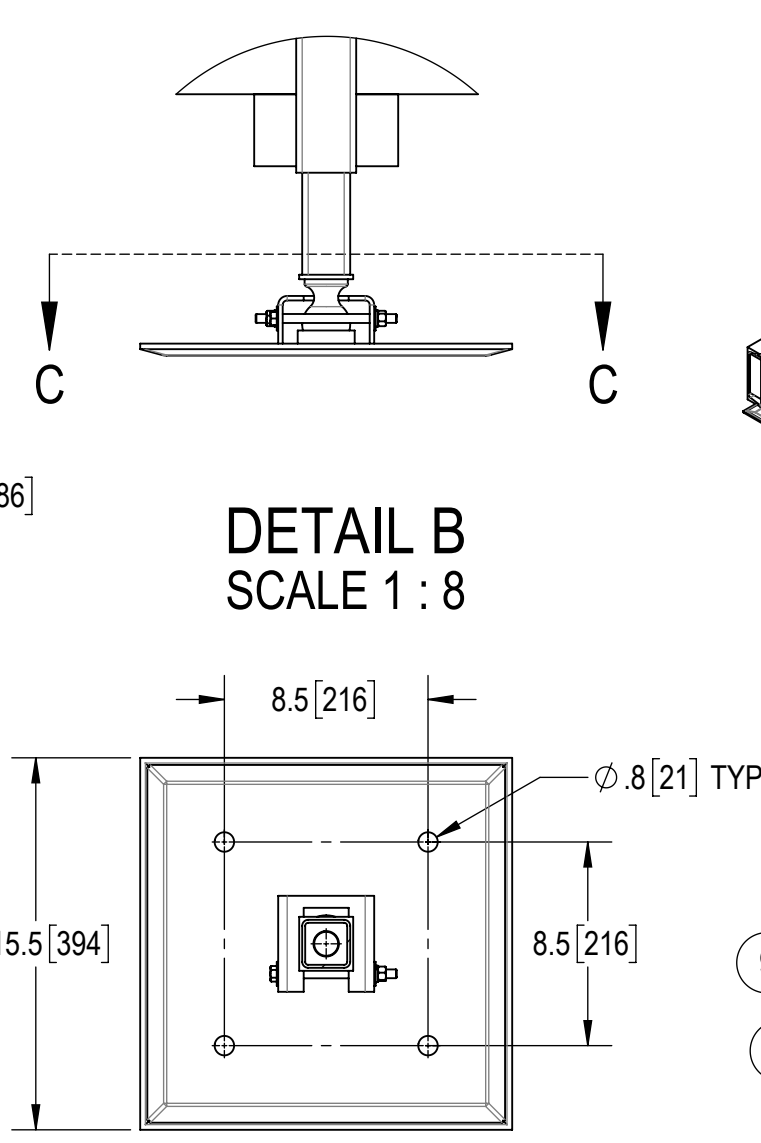
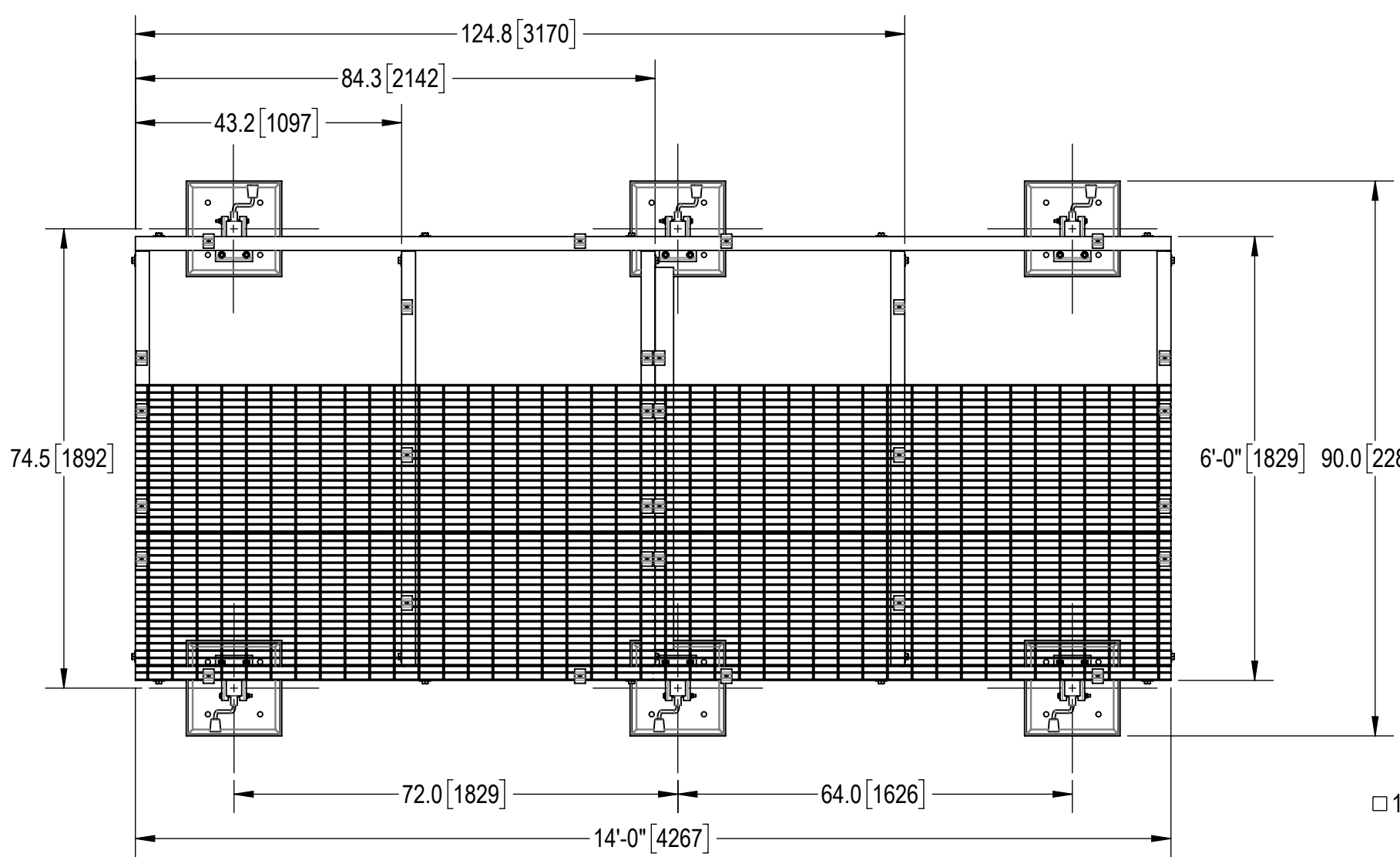

COMPONENT PART NUMBERS PROVIDED FOR ASSEMBLY PURPOSES;
 INDIVIDUAL COMPONENTS MAY BE SHIPPED AS PARTS WITHIN AN INCLUDED KIT.

ITEM	PART NO.	DESCRIPTION	QTY.	WEIGHT	NOTE NO.
1	MTC8822061001	6' CENTER CHANNEL	5	63.61 LBS	
2	MTC7902141401	14' SIDE CHANNEL	2	159.09 LBS	
3	MTC7902040703	24" X 84" BAR GRATING	6	99.01 LBS	
4	MTC7902061601	GRATING SECTION BRACKET	1	29.46 LBS	
5	MTC790203	CHANNEL ADAPTER ANGLE	10	7.07 LBS	
6	GB-05205	5/8" X 2" GALV BOLT KIT	43	0.26 LBS	
7	GWF-05	5/8" GALV FLAT WASHER, 1.7OD	86	0.06 LBS	
8	MTC390324	BAR GRATING CLIP	30	0.17 LBS	
9	TS1220	12-24 X 2" SELF DRILLING SCREW	30	0.03 LBS	
10	EQ-P-AL	ADJ. LEG FOR EQUIPMENT PLATFORMS	6	56 LBS	

DENSITY	1693.06	lbs/in ³
MASS	1693.06	lbs
VOLUME	5724.39	in ³
SURFACE AREA	55192.75	in ²
HEIGHT	16.5"	
LENGTH	168.0"	
WIDTH	90.0"	

COMMSCOPE, INC. OF NORTH CAROLINA

TOLERANCES: 1 PLACE .X[X] ± 0.12[3.0], 2 PLACE .XX[X] ± 0.06[1.5], 3 PLACE .XXX[X] ± 0.031[0.8], ANGLES ± 2°

SAP MATERIAL MASTER: EQ-P0614-AL

FINISH: [Blank] MATERIAL: [Blank]

UNLESS OTHERWISE SPECIFIED DIMENSIONS ARE IN INCHES INTERPRET PER ANSI Y 14.5M-1994

NAME	DATE	TITLE
CE DRR	04APR12	6' X 14' EQUIPMENT PLATFORM (6) EQ-P-AL
RW LL1090	08/23/2024	
AD YC1015	08/25/2024	
RE YMENG	08/26/2024	

SCALE: 1:24 DOCUMENT NO.: EQ-P0614-AL

SIZE	Auth Group	INSL	MODEL	DRAWING			SHEET
C	[Symbol]	[Symbol]	00 RE B	VERSION	STATUS	REVISION	00 RE B

© 2024 CommScope, Inc. Confidential