

4

3

2

1

- 1.0 GENERAL NOTES
 - 1.1 ALL METRIC DIMENSIONS ARE IN BRACKETS [X.X]
 - 1.2 FEATURES CRITICAL TO QUALITY ARE INDICATED IN ROUNDED BOX (XX)
 - 1.3 3D DIGITAL FILES ARE FOR REFERENCE. IN CASE OF CONFLICT FOLLOW PDF DRAWING
- 2.0 DESIGN NOTES
- 3.0 MANUFACTURING/SPECIAL REQUIREMENTS
 - 3.1 BREAK SHARP EDGES AND DEBURR PART FOR SAFE HANDLING
 - 3.2 GALVANIZE PER ASTM A123
 - 3.3 MARK WITH PART NUMBER, REVISION, AND VENDOR ID WITH ETCH, STAMP OR LABEL. CHARACTERS TO BE 0.12" TO 0.24" HIGH AND LEGIBLE TO THE UNAIDED EYE.
- 4.0 TEST
- 5.0 PACKAGING
 - 5.1 PACKAGING SHALL MEET COMMSCOPE REQUIREMENTS PER DOCUMENT IS-PL-3005

REVISIONS			
REV.	DESCRIPTION	DATE	APPROVED
A	INITIAL RELEASE	YMENG 05AUG24	BA1025 40201651CMO
B	UPDATED NOTES AND REMOVED BARE LEVEL	YMENG 14AUG24	BA1025 40202145CMO

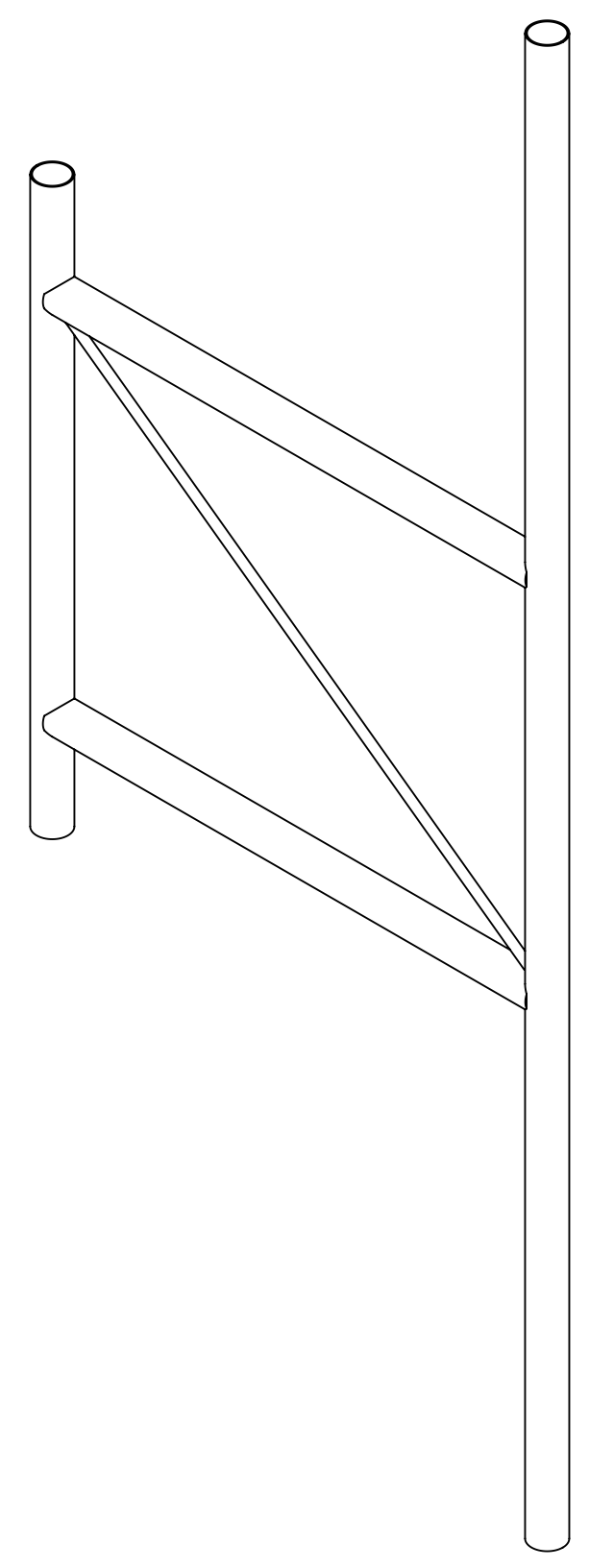
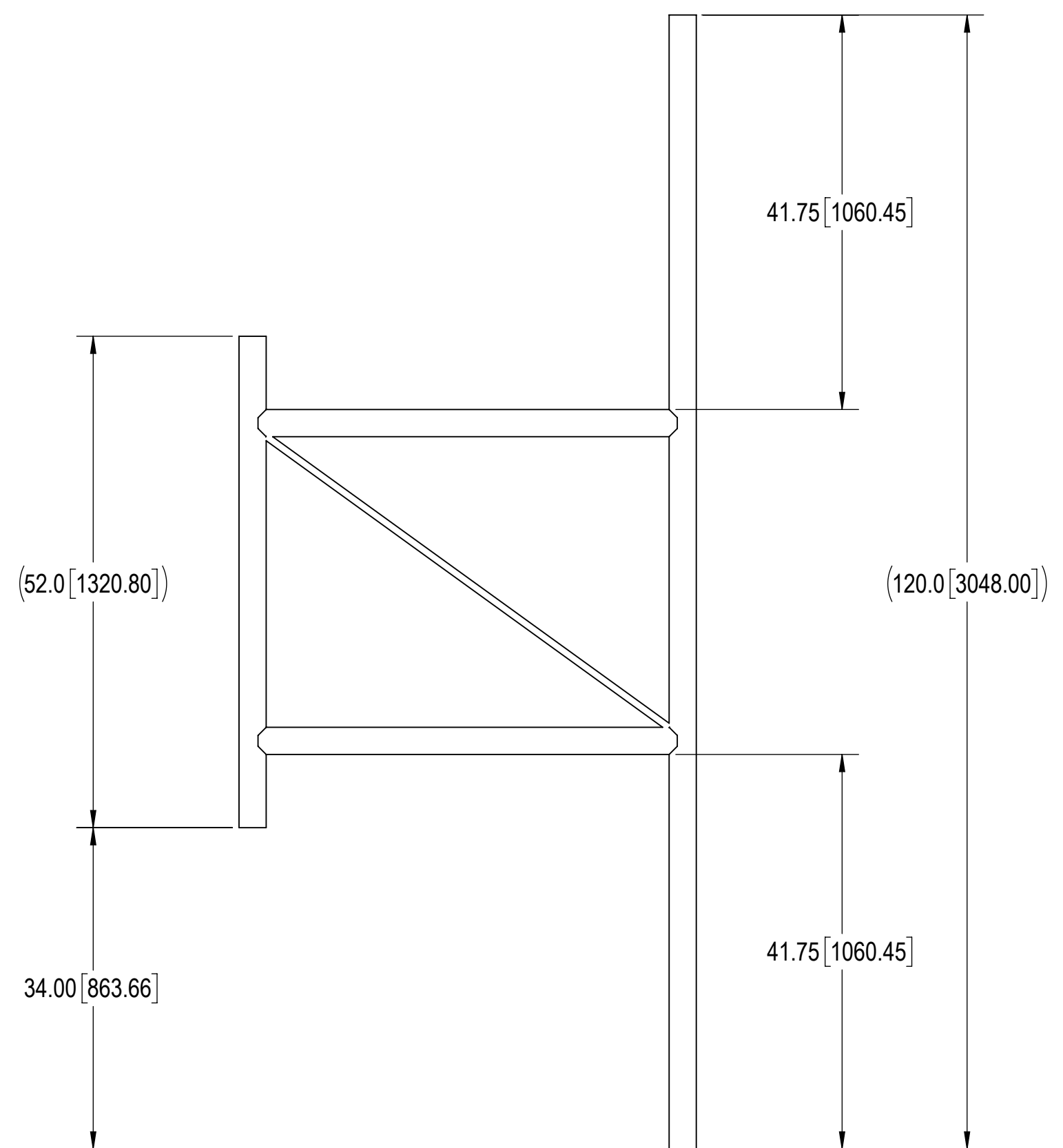
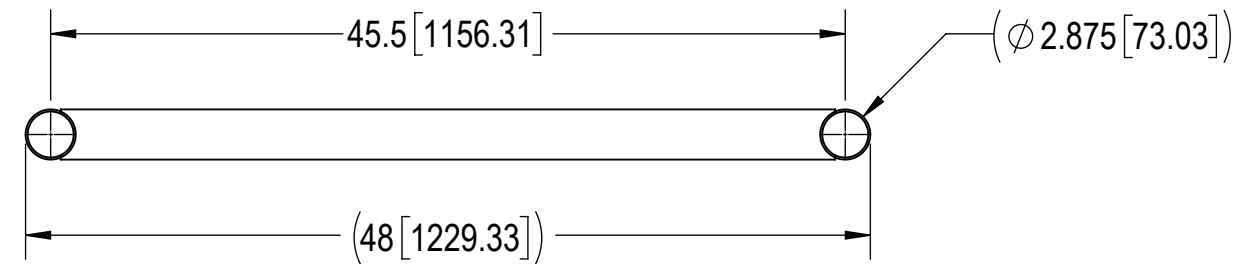

COMMSCOPE, INC. OF NORTH CAROLINA

TOLERANCES		SAP MATERIAL MASTER																																																
1 PLACE .X[X] ± 0.2[6.3]	3 PLACE .XXX[X] ± 0.060[1.5]	P-400-HD																																																
2 PLACE .XX[X] ± 0.12[3.0]	ANGLES ± 2°																																																	
FINISH GALV A123		MATERIAL A500, A529																																																
<table border="1" style="font-size: small;"> <thead> <tr> <th></th> <th>NAME</th> <th>DATE</th> <th>TITLE</th> </tr> </thead> <tbody> <tr> <td>CE</td> <td>YMENG</td> <td>05AUG24</td> <td rowspan="5" style="text-align: center;">PANEL ANT STANDOFF BRK 48" 2-7/8" PIPE</td> </tr> <tr> <td>RW</td> <td>YMENG</td> <td>08/13/2024</td> </tr> <tr> <td>AD</td> <td>BA1025</td> <td>08/15/2024</td> </tr> <tr> <td>RE</td> <td>YMENG</td> <td>08/15/2024</td> </tr> <tr> <td>ECN</td> <td>40202145CMO</td> <td></td> </tr> </tbody> </table>			NAME	DATE	TITLE	CE	YMENG	05AUG24	PANEL ANT STANDOFF BRK 48" 2-7/8" PIPE	RW	YMENG	08/13/2024	AD	BA1025	08/15/2024	RE	YMENG	08/15/2024	ECN	40202145CMO		SCALE 1:16	DOCUMENT NO. P-400-HD																											
	NAME	DATE	TITLE																																															
CE	YMENG	05AUG24	PANEL ANT STANDOFF BRK 48" 2-7/8" PIPE																																															
RW	YMENG	08/13/2024																																																
AD	BA1025	08/15/2024																																																
RE	YMENG	08/15/2024																																																
ECN	40202145CMO																																																	
<table border="1" style="font-size: x-small;"> <tr> <td>DENSITY</td> <td>82.54</td> <td>lbs/in³</td> </tr> <tr> <td>MASS</td> <td></td> <td>lbs</td> </tr> <tr> <td>VOLUME</td> <td>292.05</td> <td>in³</td> </tr> <tr> <td>SURFACE AREA</td> <td>4616.19</td> <td>in²</td> </tr> <tr> <td>HEIGHT</td> <td>120"</td> <td></td> </tr> <tr> <td>LENGTH</td> <td>48"</td> <td></td> </tr> <tr> <td>WIDTH</td> <td>2.88"</td> <td></td> </tr> </table>		DENSITY	82.54	lbs/in ³	MASS		lbs	VOLUME	292.05	in ³	SURFACE AREA	4616.19	in ²	HEIGHT	120"		LENGTH	48"		WIDTH	2.88"		<table border="1" style="font-size: x-small;"> <tr> <th>SIZE</th> <th>Auth Group</th> <th>INSL</th> <th colspan="3">MODEL</th> <th colspan="3">DRAWING</th> <th>SHEET</th> </tr> <tr> <td rowspan="2" style="text-align: center;">C</td> <td rowspan="2" style="text-align: center;">⊕</td> <td rowspan="2" style="text-align: center;">◁</td> <td>VERSION</td> <td>STATUS</td> <td>REVISION</td> <td>VERSION</td> <td>STATUS</td> <td>REVISION</td> <td rowspan="2" style="text-align: center;">1 OF 1</td> </tr> <tr> <td>00</td> <td>RE</td> <td>A</td> <td>01</td> <td>RE</td> <td>B</td> </tr> </table>		SIZE	Auth Group	INSL	MODEL			DRAWING			SHEET	C	⊕	◁	VERSION	STATUS	REVISION	VERSION	STATUS	REVISION	1 OF 1	00	RE	A	01	RE	B
DENSITY	82.54	lbs/in ³																																																
MASS		lbs																																																
VOLUME	292.05	in ³																																																
SURFACE AREA	4616.19	in ²																																																
HEIGHT	120"																																																	
LENGTH	48"																																																	
WIDTH	2.88"																																																	
SIZE	Auth Group	INSL	MODEL			DRAWING			SHEET																																									
C	⊕	◁	VERSION	STATUS	REVISION	VERSION	STATUS	REVISION	1 OF 1																																									
			00	RE	A	01	RE	B																																										

4

3

2

1