



OmniReach[®] FDH 3000

Indoor 432 Cabinet With Multi-Fiber Connectors

User Manual

ADCP-96-142 • Issue 2 • 3/2009

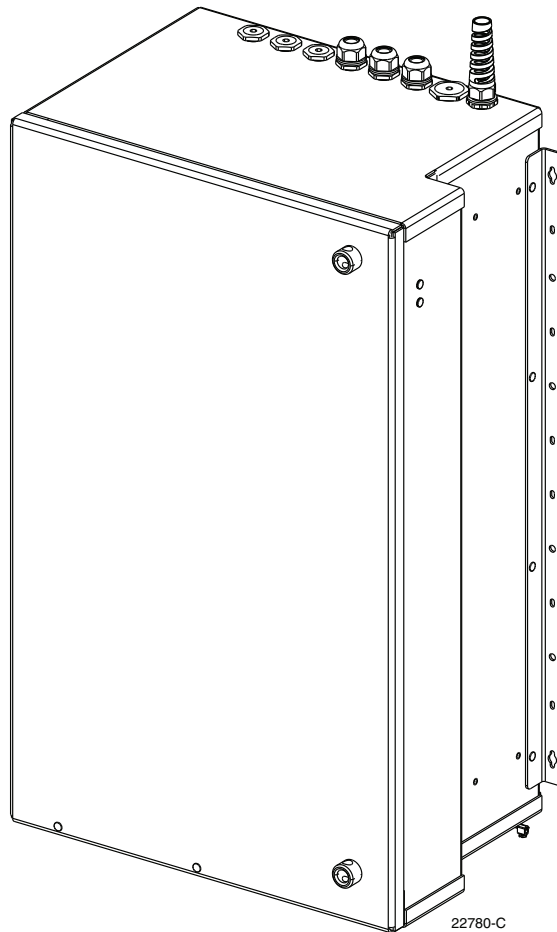

COPYRIGHT

© 2009, ADC Telecommunications, Inc.
All Rights Reserved

REVISION HISTORY

ISSUE	DATE	REASON FOR CHANGE
1	8/2008	Original release.
2	3/2009	Cabinet redesigned to accommodate bottom cable entry. New cable clamps for maximum cable retention. Swingframe redesigned.

LIST OF CHANGES

The technical changes incorporated into this issue are listed below.

PAGE	IDENTIFIER	DESCRIPTION OF CHANGE
-	Sec 7, 9	Included new sections to cover routing cables into the cabinet from the bottom.
19, 32	-	Revised cable clamp installation procedures to include new clamp.
-	-	Updated drawings as needed to show new swingframe.

TRADEMARK INFORMATION

ADC, ADC Telecommunications, and OmniReach are registered trademarks of ADC Telecommunications, Inc.

Telcordia is a registered trademark of Telcordia Technologies, Inc.

GORE is a registered trademark of W. L. Gore & Associates, Inc.

MTP is a registered trademark of US Conec Ltd.

DISCLAIMER OF LIABILITY

Contents herein are current as of the date of publication. ADC reserves the right to change the contents without prior notice. **In no event shall ADC be liable for any damages resulting from loss of data, loss of use, or loss of profits and ADC further disclaims any and all liability for indirect, incidental, special, consequential or other similar damages. This disclaimer of liability applies to all products, publications and services during and after the warranty period.**

This publication may be verified at any time by contacting ADC's Technical Assistance Center at 1-800-366-3891, extension 73475 (in U.S.A. or Canada) or 952-917-3475 (outside U.S.A. and Canada), or by e-mail to connectivity_tac@adc.com.



ADC Telecommunications, Inc.
P.O. Box 1101, Minneapolis, Minnesota 55440-1101
In U.S.A. and Canada: 1-800-366-3891
Outside U.S.A. and Canada: (952) 938-8080
Fax: (952) 917-1717

TABLE OF CONTENTS

Content	Page
ABOUT THIS MANUAL	v
RELATED PUBLICATIONS	v
ADMONISHMENTS	v
GENERAL SAFETY PRECAUTIONS	v
STANDARDS CERTIFICATION	vi
LIST OF ACRONYMS AND ABBREVIATIONS	vi
1 DESCRIPTION	1
2 BEFORE STARTING THE INSTALLATION	5
2.1 Installation Overview	5
2.2 Unpacking and Inspection	5
2.3 Cabinet Installation Hardware	6
2.4 Feeder Cable and Cabinet Grounding	6
2.5 Tools and Materials Required for Installation	6
3 MOUNTING THE CABINET IN THE EQUIPMENT RACK	7
3.1 Rack Installation Recommendations	7
3.2 Installing The Cabinet In The Equipment Rack	7
3.3 Grounding Wire Connection To Cabinet	12
4 MOUNTING THE CABINET ON A WALL	13
4.1 Wood-Framed Wall Mounting Procedure	13
4.2 Grounding Wire Connection To Cabinet	14
5 PRE-INSTALLED FEEDER CABLE CONFIGURATION	16
6 FEEDER CABLE INSTALLATION AND SPLICING - TOP ENTRY/EXIT	17
6.1 Feeder Cable Installation	17
6.2 Grounding Cables with Metallic Members	19
6.3 Splicing the Feeder Cable Fibers to the Splitter Fibers - Ribbon Fiber	20
6.4 Splicing the Feeder Cable Fibers to the Splitter Fibers - Stranded Fiber	25
7 FEEDER CABLE INSTALLATION AND SPLICING - BOTTOM ENTRY/EXIT	28
7.1 Bottom Entry/Exit Feeder Cable Installation	28
7.2 Grounding Cables with Metallic Members	33
7.3 Splicing the Feeder Cable Fibers to the Splitter Fibers - Ribbon Fiber	34
7.4 Splicing the Feeder Cable Fibers to the Splitter Fibers - Stranded Fiber	38
8 DISTRIBUTION CABLE INSTALLATION AND ROUTING - TOP ENTRY/EXIT	42
9 DISTRIBUTION CABLE INSTALLATION AND ROUTING - BOTTOM ENTRY/EXIT	48
10 PLUG AND PLAY SPLITTER MODULE INSTALLATION	54
11 DISTRIBUTION PANEL INSTALLATION	57
12 ROUTING AND CONNECTING THE SPLITTER OUTPUT FIBERS	61
12.1 Storing The Splitter Output Fibers	61
12.2 Enabling Service To a Subscriber	62
13 PASS-THROUGH ROUTING PROCEDURE	63
13.1 Sliding Adapter Pack Pass-Through Routing Procedure	63
13.2 Splitter Compartment Pass-Through Routing Procedure	65

TABLE OF CONTENTS

Content	Page
14 FEEDER CABLE FIBER RE-ROUTING PROCEDURE	67
15 MAINTENANCE AND REPAIR PROCEDURES	70
15.1 Painting	70
15.2 Distribution Panel Adapter Replacement	70
15.3 Splitter Compartment Adapter Replacement	71
15.4 Replacing a Damaged Fiber or Connector	72
15.5 Door Gasket Replacement	73
15.6 Door Replacement	73
16 CUSTOMER INFORMATION AND ASSISTANCE	76

ABOUT THIS MANUAL

This publication describes the OmniReach FDH 3000 indoor 432 cabinet with multi-fiber connectors. Also included are procedures for mounting the cabinet, installing connectorized distribution cables, installing and splicing feeder cables, installing additional splitter modules, installing additional distribution panels, storing the splitter output fibers, connecting the splitter output fibers to the distribution fibers, and replacing damaged components.

RELATED PUBLICATIONS

Listed below are related manuals and their publication numbers. Copies of these publications can be ordered by contacting the ADC Technical Assistance Center at 1-800-366-3891, extension 73475 (in U.S.A. or Canada) or 1-952-917-3475 (outside U.S.A. and Canada).

Title	ADCP Number
Optical Fiber Connector Wet and Dry Cleaning Instructions	90-159
FDH 3000 Cabinet Plug And Play Splitter Installation Instructions	96-087
Multifiber-Push On Assembly Connector Cleaning Instructions	96-150

ADMONISHMENTS

Important safety admonishments are used throughout this manual to warn of possible hazards to persons or equipment. An admonishment identifies a possible hazard and then explains what may happen if the hazard is not avoided. The admonishments — in the form of Dangers, Warnings, and Cautions — must be followed at all times. These warnings are flagged by use of the triangular alert icon (seen below) and are listed in descending order of severity of injury or damage and likelihood of occurrence.



Danger: *Danger is used to indicate the presence of a hazard that **will** cause severe personal injury, death, or substantial property damage if the hazard is not avoided.*



Warning: *Warning is used to indicate the presence of a hazard that **can** cause severe personal injury, death, or substantial property damage if the hazard is not avoided.*



Caution: *Caution is used to indicate the presence of a hazard that **will** or **can** cause minor personal injury or property damage if the hazard is not avoided.*

GENERAL SAFETY PRECAUTIONS



Warning: *Wet conditions increase the potential for receiving an electrical shock when installing or using electrically-powered equipment. To prevent electrical shock, never install or use electrical equipment in a wet location or during a lightning storm.*



Danger: Do not look into the ends of any optical fiber. Exposure to laser radiation may result. Do not assume the laser power is turned-off or that the fiber is disconnected at the other end.



Danger: Use adequate lifting equipment when moving or installing Fiber Distribution Hub cabinets. Verify that the maximum lift weight rating of the equipment is sufficient to handle the weight of the cabinet.



Danger: Do not stand under a Fiber Distribution Hub cabinet as it is being hoisted into position for mounting. A failure of the lifting equipment or apparatus could result in serious personal injury and cause significant damage to the cabinet.



Warning: Before digging, check with all local utilities for the presence of buried cables or pipes. Contact with underground cables or pipes, especially electric power cables and gas service lines, could interrupt local utility service and cause serious personal injury and extensive property damage.

STANDARDS CERTIFICATION

Verizon: This equipment complies with the applicable sections of VZ.TPR.9420.

UL: This equipment is UL listed. Refer to file E114344 for complete information.

LIST OF ACRONYMS AND ABBREVIATIONS

The acronyms and abbreviations used in this manual are detailed in the following list:

AWG	American Wire Gauge
C	Centigrade
F	Fahrenheit
FDH	Fiber Distribution Hub
FTTP	Fiber To The Premises
I/O	Indoor/Outdoor
MTP	Mechanical Transfer Pull-Off
OSP	Outside Plant
PNP	Plug and Play
RBR	Reduced Bend Radius

1 DESCRIPTION

This section provides a description of the OmniReach FDH 3000 indoor 432 cabinet with multi-fiber connectors plus a table of the cabinet specifications.

The indoor 432 cabinet is a secure fiber optic distribution cabinet that is designed to hold the optical components required for Fiber To The Premises (FTTP) distribution network applications. The cabinet is designed for **rack-mount** and **wall-mount** applications. The rack-mount cabinet may be mounted in a 23-inch, WECO or EIA equipment rack. A typical cabinet is shown in [Figure 1](#).

The cabinet is available with a factory-installed feeder cable or with no cables installed. The factory-installed feeder cable can be ordered with multiple stub lengths. Either ribbon or stranded type feeder cable is available. The feeder cable may be dielectric or include metallic elements.

The distribution cables must be ordered separately and must be installed after the cabinet is mounted. Distribution cables must be rated for indoor use and designed for reduced bend radius applications. In addition, each distribution cable must be a 3 mm, stranded, 12-fiber cable terminated with a 12-fiber Mechanical Transfer Pull-Off (MTP®) connector.

The feeder and distribution cables enter/exit the cabinet from either the top or the bottom. Compression fittings are used to secure the cables to the outside of the cabinet. The compression fittings also prevent dirt and moisture from entering the cabinet at the cable entry/exit points. The feeder cable is also secured to the inside of the cabinet with a clamp. When a factory-installed feeder cable is not ordered, a splice tray is provided. Either a ribbon cable tray or a stranded cable tray may be specified.

The interior of the cabinet consists of the following primary components.

Distribution Panels: Provide a point for connecting the splitter output fibers to the terminated distribution cable fibers. Each panel provides mounting spaces for 72 bulkhead adapters. A maximum of six distribution panels may be mounted in the cabinet.

Storage Panel: Provides a temporary “parking lot” for unused splitter output fibers. Each splitter module is equipped with either 8-position connector packs (8-packs) or 16-position connector packs (16-packs). Up to eighteen 8-packs can be mounted in the 8-pack storage panel and up to six 16-position connector packs can be mounted in the 16-pack storage panel.

Radius Limiters: Provide a place for storing excess slack from the splitter output fibers.

Splitter Compartment: Provides a place for mounting the splitters. Will support up to twenty-two splitters. Unused splitter slots can be used for pass-through fibers. The splitters specified for use with the indoor FDH 3000 cabinet are equipped with reduced bend radius (RDR) fibers.

Sliding Adapter Pack (Input panel): Provides a place for terminating spare feeder cable fibers. Spare feeder cable fibers may be used for signal pass-through functions.

Adapter Panel: Provides a point for connecting the distribution cables to the distribution panel cable assemblies. Both the distribution cables and the distribution panel cable assemblies are terminated with 12-fiber MTP® connectors. Bulkhead adapters are mounted on the adapter panel for linking the appropriate connectors together

Grounding Block: Provides a point for grounding feeder cables with metallic elements.

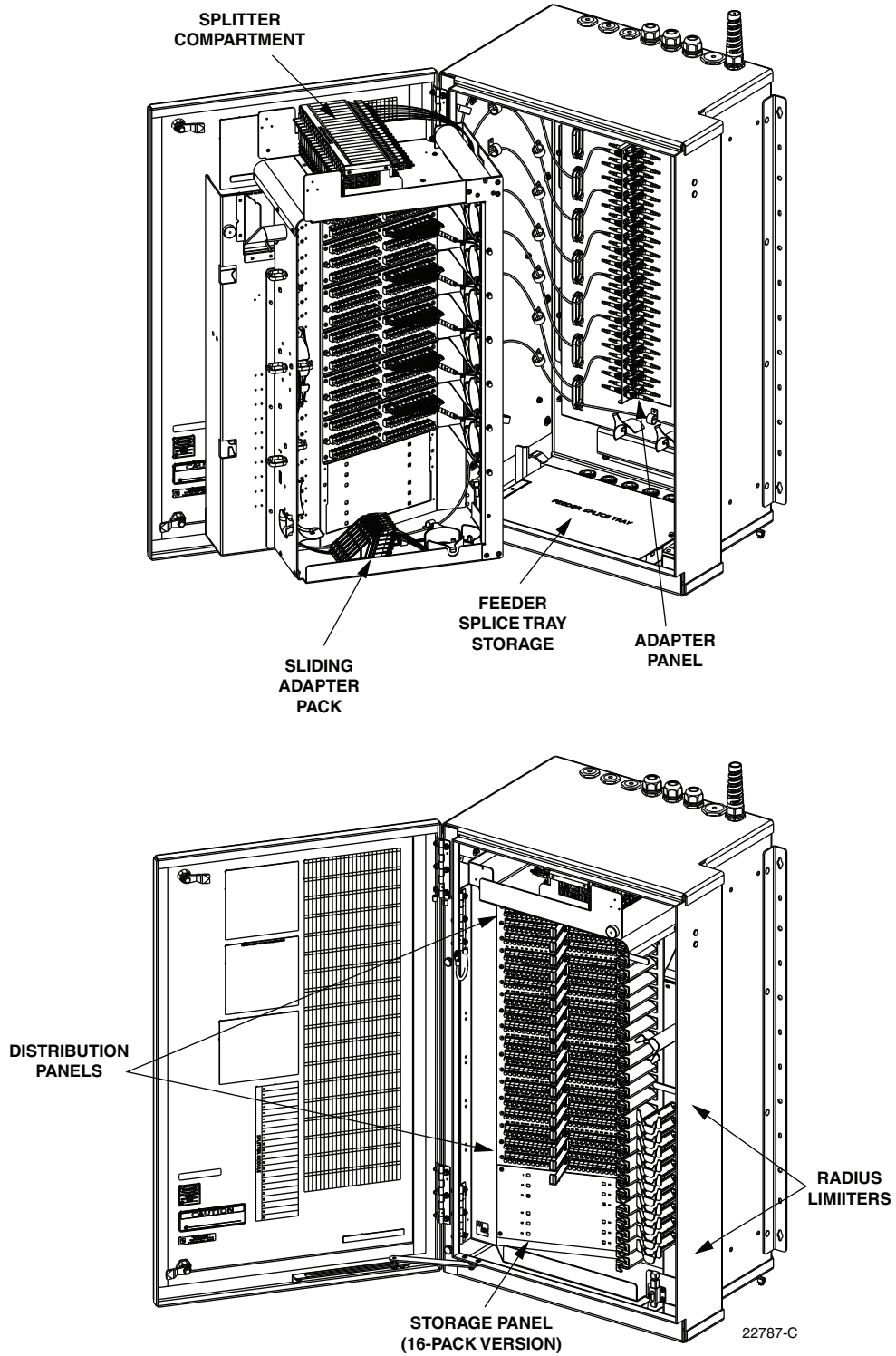

Figure 1. Typical FDH 3000 Indoor 432 Cabinet with Multi-Fiber Connectors

Feeder Cable Splice Tray Storage: Provides storage space for up to two 5 x 11.75 inch rectangular splice trays when the feeder cable fibers are spliced to the splitter input pigtails. Will accommodate ribbon cable or stranded cable splice trays. The ribbon cable tray provides storage space for up to 72 splices and the stranded cable tray provides storage space for up to 36 splices.

The exterior shell of the cabinet is constructed of heavy gauge aluminum and coated with an almond-colored finish. Each cabinet is equipped with a single front door that provides full access to the optical components. The door is equipped with two tamper-resistant latches, stainless steel hinges, and a catch that prevents accidental closing. Access to the cabinet requires a 216B key tool (accessory) to release the each latch. GORE membrane vents are provided to release any water vapor that may accumulate within the cabinet. A drain hole is also provided in the bottom of the cabinet. The specifications for the FDH 3000 indoor 432 cabinet with multi-fiber connectors are provided in [Table 1](#).

Table 1. FDH 3000 Indoor 432 Cabinet With Multi-Fiber Connectors Specifications

PARAMETER	SPECIFICATION
Cabinet	
Dimensions (H x W x D) See Figure 2	39.13 x 23.46 x 16.78 x inches (99.39 x 59.6 x 42.6 cm)
Weight (fully loaded)	150 lbs (68 kg)
Certification	Applicable sections of VZ.TPR.9420 UL Listed: See file E114344 for complete information.
Distribution panels (maximum)	6
Distribution ports	Up to 432 with six 72-port distribution panels.
Distribution port adapters/connectors	UPC/SC or APC/SC,
Feeder cable requirements	24-, 48-, or 72-fiber cable, ribbon or stranded construction (If brass cable clamps are included with the cabinet, the feeder cable should be 0.51 inches in diameter)
Splitter compartment splitter capacity	22 splitters
Splitter compartment adapter capacity	44 adapters
Splitter output fiber storage panel capacity (Note: dependent on cabinet options)	144 connectors with 8-pack storage panel (8 x 18) 96 connectors with 16-pack storage panel (6 x 16)
Sliding adapter pack capacity	30 adapters
Feeder splice tray storage capacity	Up to 2 splice trays
Splice tray splice capacities Stranded cable splice trays Ribbon cable splice trays	Up to 36 splices per tray Up to 72 splices per tray
Splitter Modules	
Splitter module input and output pigtails	Reduced bend radius fiber terminated with UPC/SC or APC/SC connectors
Test bandpass	1260–1360 nm, 1480–1500 nm, 1550–1560 nm
Overall bandpass	1260–1625 nm

Table 1. FDH 3000 Indoor 432 Cabinet With Multi-Fiber Connectors Specifications, continued

PARAMETER	SPECIFICATION
Return loss at test bandpass	≥55 dB
Maximum insertion loss at test bandpass	Note: Specification includes the loss from the input and output connectors
1 x 2	4.1 dB with UPC, 4.3 with APC
1 x 4	7.6 dB with UPC, 7.8 dB with APC
1 x 8	10.7 dB with UPC, 10.9 dB with APC
1 x 16	13.9 dB with UPC, 14.1 dB with APC
1 x 32	17.1 dB with UPC, 17.3 dB with APC
1 x 64	20.8 dB with UPC, 21 dB with APC
2 x 16	14.5 dB with UPC, 14.7 dB with APC
2 x 32	17.8 dB with UPC, 18 with APC

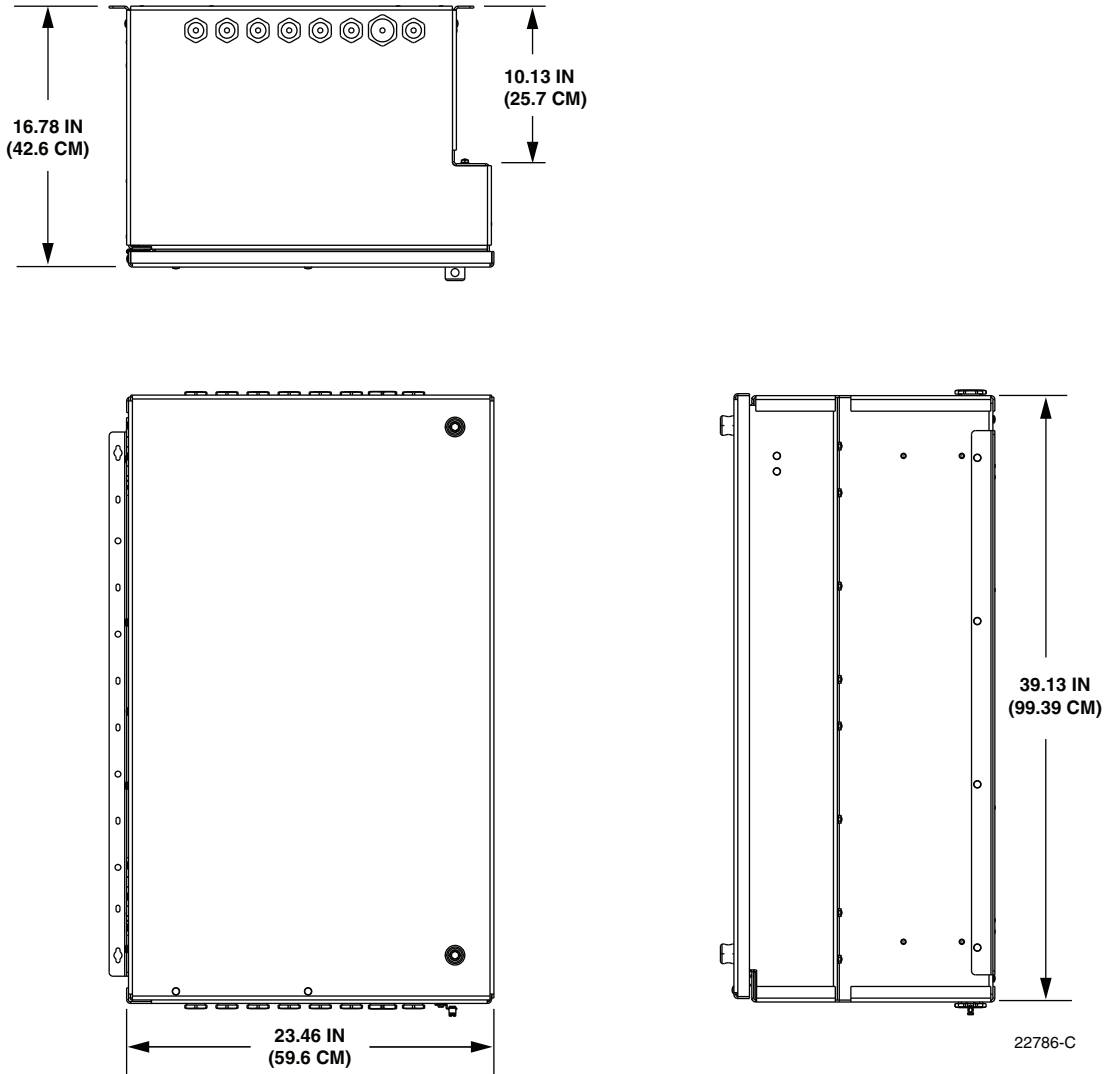

Figure 2. FDH 3000 Indoor 432 Cabinet With Multi-Fiber Connectors Dimensions

2 BEFORE STARTING THE INSTALLATION

This section provides general installation considerations, unpacking and inspection procedures, and lists the tools and materials required for installing the FDH 3000 indoor 432 cabinet with multi-fiber connectors.

2.1 Installation Overview

Installation of the indoor 432 cabinet involves the following main tasks:

Mounting the Cabinet – The cabinet must be secured to an equipment rack or wall. If the cabinet is equipped with a factory-installed feeder cable, the cable stub must be uncoiled and routed to a separate splice enclosure (not provided). Use appropriate lifting equipment when placing the cabinet in position for mounting. It is recommended that at least **two** persons be allocated for positioning and mounting the cabinet.

Splitter Installation – The cabinet may be ordered with no splitters installed or with one or two splitters installed. If additional splitters are required, they must be ordered separately. All splitter modules that are ordered separately must be installed in the splitter compartment.

Feeder Cable Installation – If the cabinet is not equipped with a factory-installed feeder cable, then a customer-supplied feeder cable must be routed into the cabinet and spliced to the splitter compartment input pigtailed. A 24- or 48-fiber cable with stranded or ribbon construction should be used for the feeder cable. If the cabinet is equipped with brass clamps, the outside diameter of the feeder cable should be 0.51 inches. Cabinets equipped with plastic cable clamps will accommodate a range of feeder cable diameters.

Distribution Cable Installation – Customer-supplied 3 mm, 12-fiber distribution cables terminated with MTP® connectors must be routed into the cabinet and connected to the distribution panel fiber sub-units.

Splitter Output Fiber Connections – Service is enabled by connecting the splitter output fiber connectors to the subscriber distribution ports. Unused output fibers are temporarily “parked” in the storage panel until they are needed for service.

2.2 Unpacking and Inspection

This section provides instructions for opening the shipping boxes, verifying that all parts have been received, and verifying that no shipping damage has occurred.

Use the following procedure to unpack and inspect the cabinet and all accessories:

1. Open the shipping carton(s) and carefully unpack the cabinet and any accessories from the protective packing material.
2. Open the cabinet doors (requires 216B key tool) and check for missing ship-along parts (see installation drawing included with cabinet) or broken parts. If there are damages, contact ADC (see [Section 16](#)) for an RMA (Return Material Authorization) and to reorder if replacement is required.

2.3 Cabinet Installation Hardware

Various parts for mounting the indoor 432 cabinet are provided with the cabinet. Some parts are placed in a plastic bag and other parts are pre-installed on the cabinet. Verify that all the parts specified in [Table 2](#) are received.

Table 2. Cabinet Installation Hardware

ITEM	QUANTITY
12-24 x 3/8-inch screw	8
#12 star washer	8
#12 flat washers	8
#12 foam washers	20
Mounting bracket (installed)	2

2.4 Feeder Cable and Cabinet Grounding

The indoor 432 cabinet is equipped with a copper block for grounding feeder cables that have metallic elements. The cabinet itself must be connected to an earth ground source. Detailed information on grounding is provided in the section that covers cabinet mounting.

2.5 Tools and Materials Required for Installation

The following tools and additional materials are required for cabinet installation:

- 216B key tool (accessory - required to open cabinet door)
- Screwdriver (flat blade-medium size)
- Screwdriver (flat blade-small size)
- Torque wrench (with 7/16-inch socket and standard screwdriver socket)
- Hammer
- Pliers
- Wire cutter
- Utility knife
- Tape measure
- Pen or marker
- Splicing equipment
- One large tweezers or two small flat-bladed screwdrivers
- Grounding system, copper wire, and grounding clamp (per local requirements)

3 MOUNTING THE CABINET IN THE EQUIPMENT RACK

The FDH 3000 indoor 432 cabinet with multi-fiber connectors may be mounted in either a WECO or EIA, 23-inch equipment rack. Sixteen 3/8-inch long 12-24 screws and sixteen #12 star washers are provided for securing the cabinet to the equipment rack.

3.1 Rack Installation Recommendations

The indoor 432 cabinet should be mounted in an equipment rack that is properly secured and grounded in accordance with local requirements. When loading the cabinet in the rack, make sure the mechanical loading of the rack is even to avoid a hazardous condition such as a severely unbalanced rack. The rack should safely support the combined weight of all the equipment it holds. Provide a minimum clearance of 24 inches (61 cm) in front of the cabinet to permit the cabinet door to be fully opened.

The cabinet occupies 39 inches (99.1 cm) of rack space. Additional rack space must be provided either above or below the cabinet for routing the distribution and feeder cables. All fiber optic cables enter/exit the cabinet from either the top or the bottom depending on the option ordered. The installer must provide any cable management devices or systems that may be required to route and secure the fiber optical cables.

Use appropriate lifting equipment when placing the cabinet in position for mounting. It is recommended that at least **two** persons be allocated for positioning and mounting the cabinet.

3.2 Installing The Cabinet In The Equipment Rack

Use the following procedure to install the indoor 432 cabinet in a 23-inch equipment rack:

1. Open the cabinet door and the swingframe as needed during this procedure to provide access to the interior of the cabinet.
2. Remove the nuts, flat washers, foam washers, and carriage bolts (four of each) that secure the **left** mounting bracket to the **left-rear** side of the cabinet as shown in [Figure 3](#).
▶ **Note:** The cabinet is shipped with the mounting brackets installed in the wall-mount position. This requires that the mounting brackets be moved to the rack-mount position.
3. Remove the **left** mounting bracket from the cabinet and place aside for reuse.
4. Reinstall the carriage bolts, foam washers (use new washers), flat washers, and nuts in the same holes from which they were removed when completing step 2. Tighten nuts securely.
▶ **Note:** Replace all used foam washers with new foam washers when reinstalling fasteners.
5. Remove the nuts, flat washers, foam washers, and carriage bolts (four of each) from the four holes located on the **left-front** side of the cabinet as shown in [Figure 4](#).
6. Using the carriage bolts, foam washers, flat washers, and nuts removed in step 5, install the left mounting bracket on the **left-front** side of the cabinet (see [Figure 4](#)). Tighten nuts securely.

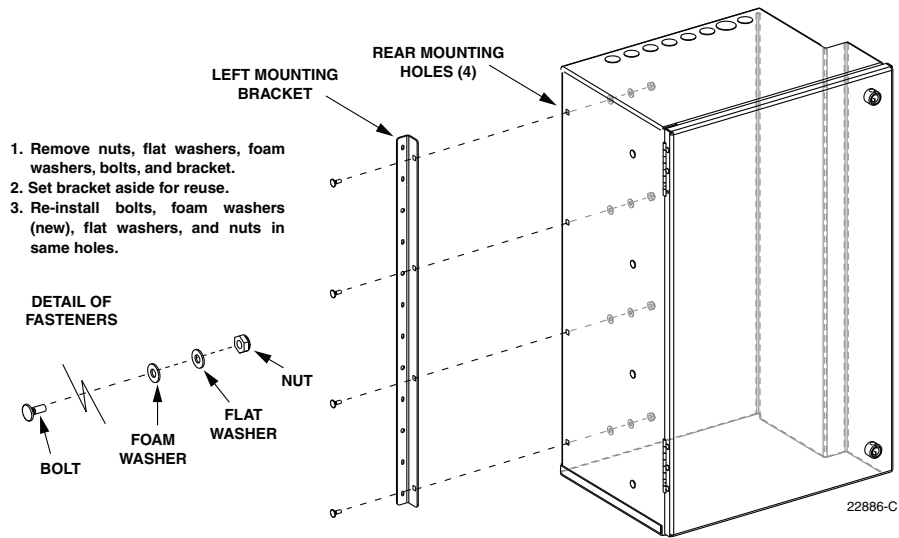

Figure 3. Remove Left Mounting Bracket From Left-Rear Mounting Position

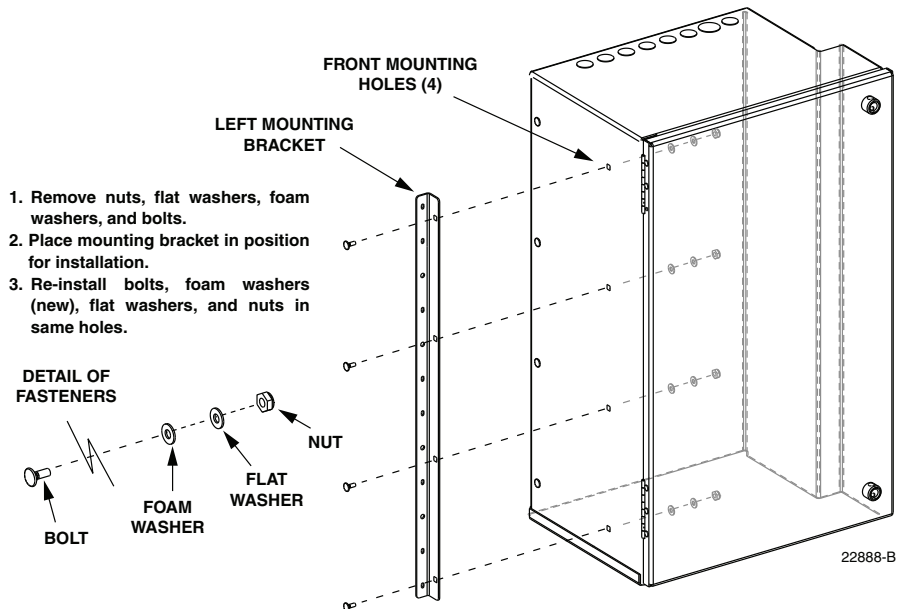

Figure 4. Install Left Mounting Bracket in Left-Front Mounting Position

7. Remove the nuts, flat washers, foam washers, and carriage bolts (four of each) that secure the **right** mounting bracket to the **right-rear** side of the cabinet as shown in [Figure 5](#).
8. Remove the **right** mounting bracket from the cabinet and discard. The right mounting bracket is not used with rack-mount applications.
9. Reinstall the carriage bolts, foam washers (use new washers), flat washers, and nuts in the same holes from which they were removed when completing step 7. Tighten nuts securely.

► **Note:** Replace all used foam washers with new foam washers when reinstalling fasteners.

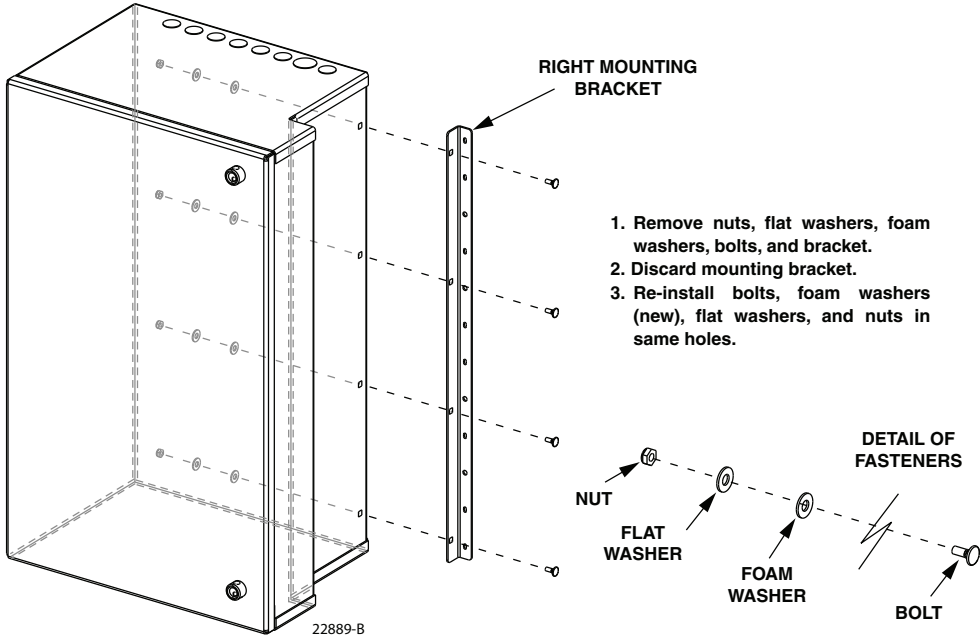

Figure 5. Remove Right Mounting Bracket From Rear Mounting Position

10. Remove the 12-24 screws, star washers, flat washers, foam washers, and 12-24 nuts (8 of each) from the **right** side rack-mount holes shown in [Figure 6](#).

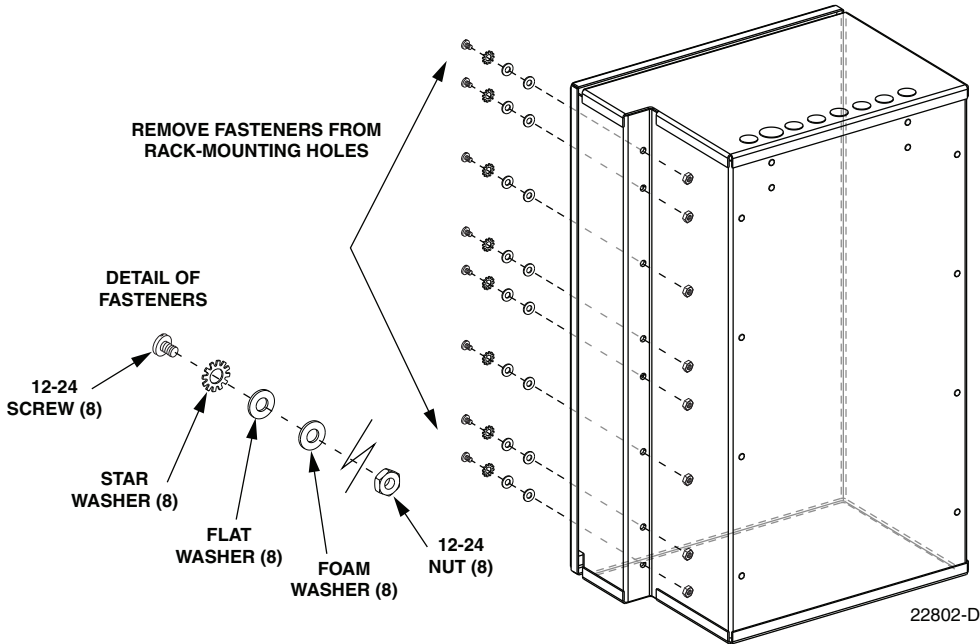

Figure 6. Remove Fasteners from Right Rack-Mounting Holes

11. Discard the nuts and foam washers removed in step 10 but save the 12-24 screws, star washers, and flat washers for reuse.
12. Locate the 12-24 rack screws and #12 star washers (8 of each) that are provided separately with the cabinet.
13. Place the cabinet in the specified mounting space within the equipment rack as shown in [Figure 7](#).
14. Install a single 12-24 rack screw (with star washer) in the top hole of the cabinet's **left** side mounting bracket (see [Figure 7](#)).

► **Note:** When installing the rack screws, tighten each screw to 27 pound-force inches (3.1 Newton-meters) of torque.

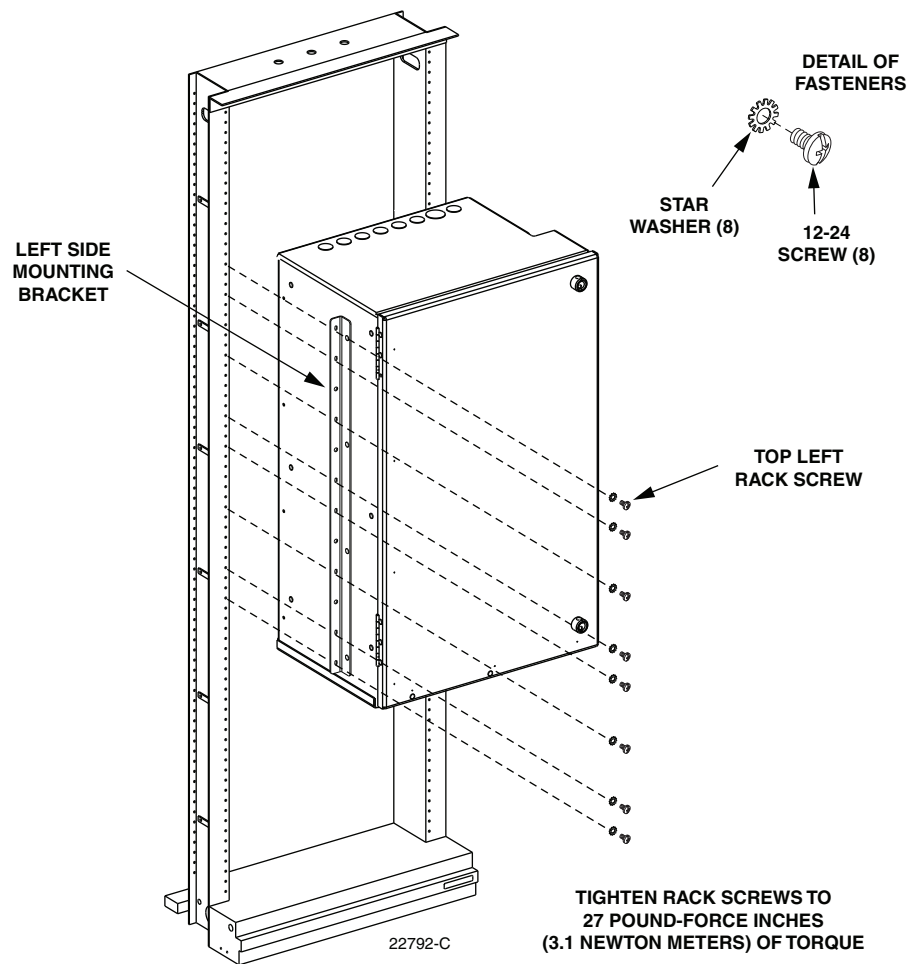

Figure 7. Placement of Cabinet in Equipment Rack

15. Open the cabinet door and install a single 12-24 rack screw (with star washer, flat washer, and **foam washer**) in the top hole on the **right** side of the cabinet as shown in [Figure 8](#).

► **Note:** Keep the cabinet swing frame closed when installing the initial rack screw(s) on the right side of the cabinet.

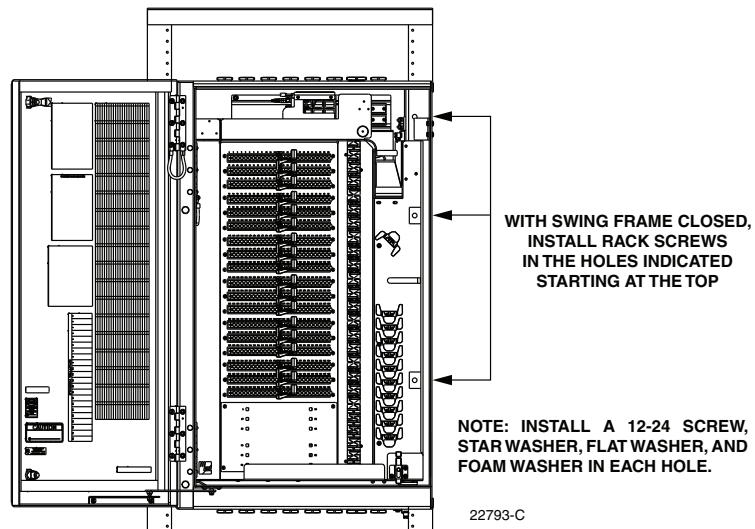

Figure 8. Right Side Mounting Holes Accessible with Swing Frame Closed

16. With the cabinet swing frame in the closed position, complete the installation of the left and right side rack screws.
17. Open the cabinet swing frame and install the remaining five right side rack screws as shown in [Figure 9](#).
18. Close the swing frame and relatch the cabinet door when finished.

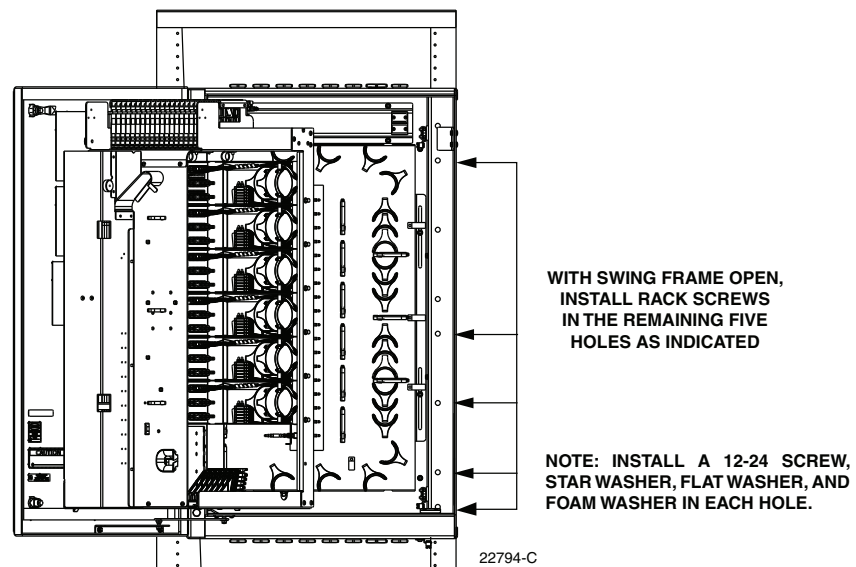

Figure 9. Right Side Mounting Holes Accessible with Swing Frame Open

3.3 Grounding Wire Connection To Cabinet

A grounding lug is provided with the cabinet for connecting a #6 copper grounding wire to the exterior of the indoor 432 cabinet. Use the following procedure to install the grounding wire:

1. Locate the cabinet grounding lug which is mounted on the underside of the cabinet as shown in [Figure 10](#).

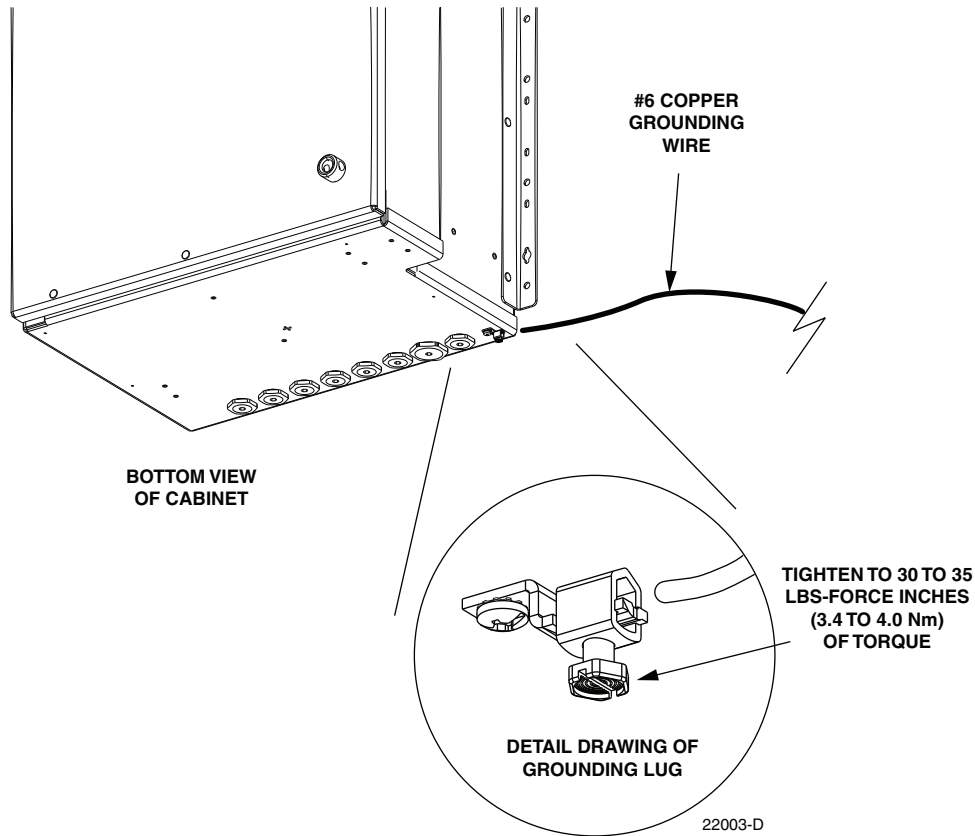

Figure 10. Grounding Wire Connection To Cabinet

2. Obtain a length of #6 AWG copper wire for use as a grounding wire.
3. Insert one end of the grounding wire into the cabinet grounding lug. Tighten the grounding lug set screw to 30 to 35 lbs-force inches (3.4 to 4.0 Nm) of torque.

► **Note:** The grounding lug provided with the cabinet can be used for #6 – #14 AWG wire.

4. Route the free end of the grounding wire to an approved earth ground source.
5. Cut the grounding wire to length and connect it to the earth ground source as specified by local code or practice.

4 MOUNTING THE CABINET ON A WALL

The FDH 3000 indoor 432 cabinet with multi-fiber connectors may be mounted from most flat vertical surfaces. Two mounting brackets are provided with the cabinet for use in wall-mount installations. Appropriate fasteners for securing the mounting brackets to the mounting surface and an appropriate backer board must be provided by the installer. The type of fasteners required are dependent on the materials and the construction of the mounting surface.

Use appropriate lifting equipment when placing the cabinet in position for mounting. It is recommended that at least **two** persons be allocated for positioning and mounting the cabinet.

4.1 Wood-Framed Wall Mounting Procedure

When mounting the cabinet on a wood-framed wall, it is recommended that pressure-treated plywood with a minimum thickness of 0.75-inch (19.0 cm) be used as a backer board. The backer **must** be firmly secured to the interior framing of the wall to avoid a hazardous condition. Use the following procedure to install the cabinet on a wood-framed wall:

1. Mount the plywood backer (not provided) on the wall and firmly secure it to the wall's interior studs.
2. Obtain the following fasteners for securing the cabinet to the plywood backer.
 - 1/4 x 1-1/2-inch lag screws –12
 - 1/4-inch flat washers – 12 for mounting plus additional washers to use as spacers
3. Using [Figure 11](#) as a guide, mark the location of the cabinet mounting holes on the plywood backer.

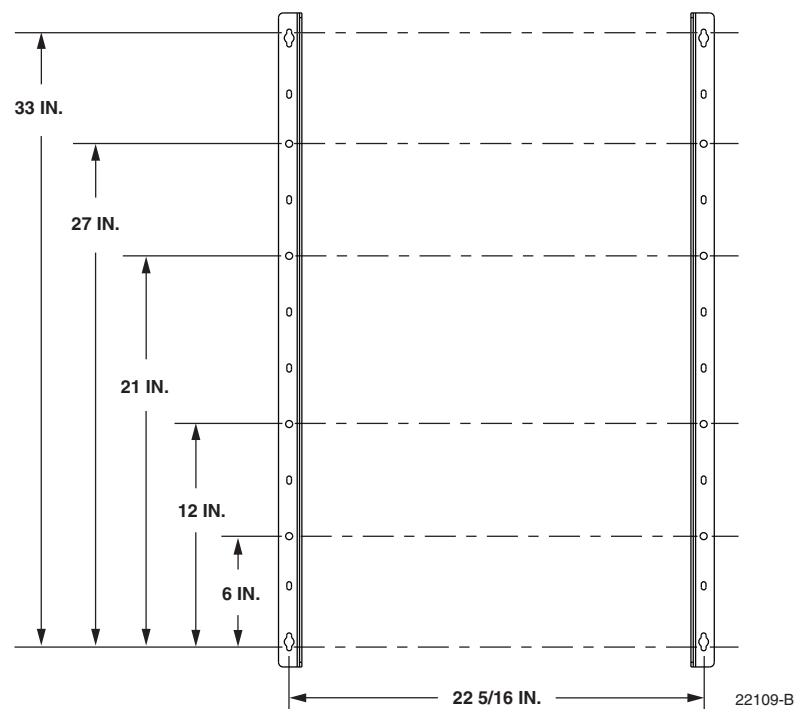

Figure 11. Hole Locations For Wall-Mount Installation

4. Drill a 5/32-inch hole in the backer board at each of the locations marked in step 4.
 5. Secure the cabinet to the plywood backer, as shown in [Figure 12](#), using the twelve 1/4 x 1-1/2-inch lag screws and 1/4-inch flat washers. Tighten lag screws securely.
- ▶ **Note:** If mounting surface is not flat, level mounting surface by placing spacers (use 1/4-inch flat washers) between the mounting brackets and mounting surface. This will prevent the cabinet from being distorted when the mounting screws are tightened.
6. Close swing frame and relatch cabinet door when finished.

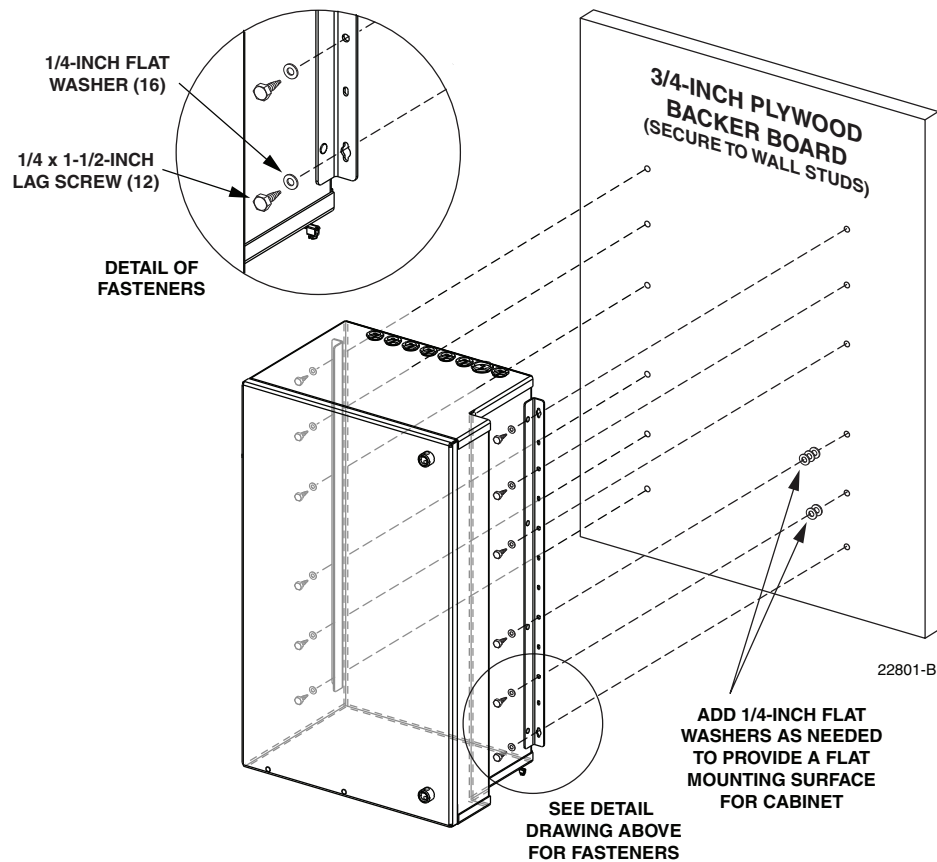

Figure 12. Secure Cabinet to Plywood Backer

4.2 Grounding Wire Connection To Cabinet

A grounding lug is provided with the cabinet for connecting a #6 copper grounding wire to the exterior of the indoor 432 cabinet. Use the following procedure to install the grounding wire:

1. Locate the cabinet grounding lug which is mounted on the underside of the cabinet as shown in [Figure 10](#).
2. Obtain a length of #6 AWG copper wire for use as a grounding wire.

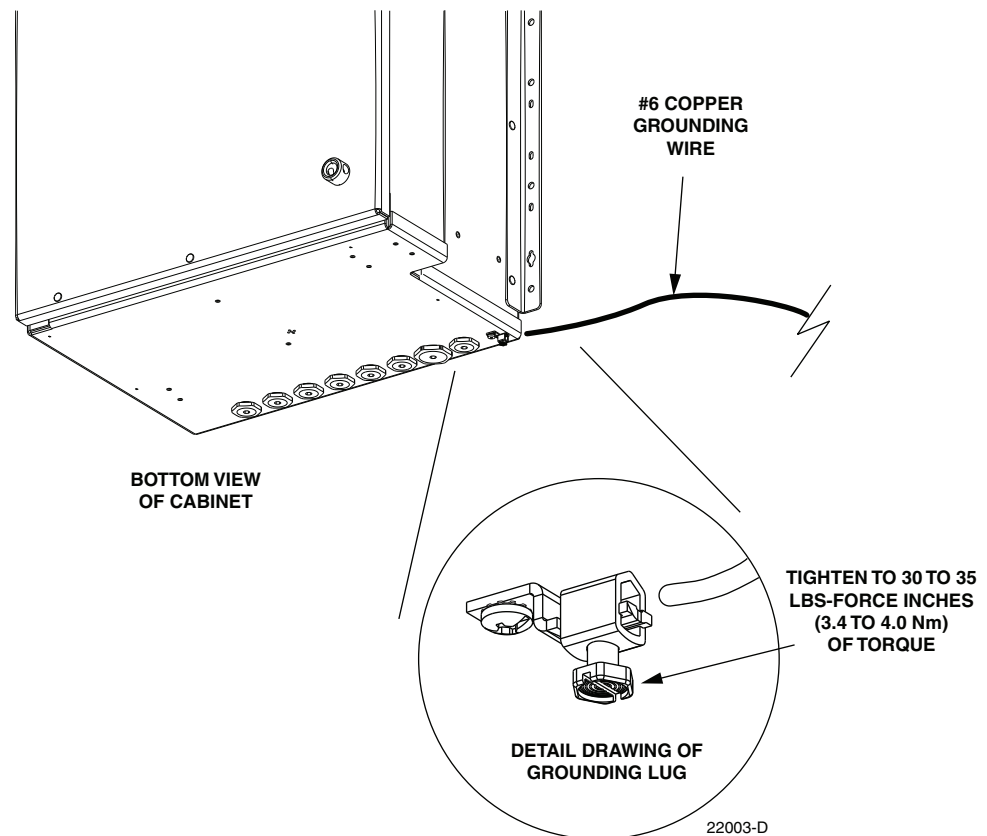

Figure 13. Grounding Wire Connection To Cabinet

3. Insert one end of the grounding wire into the cabinet grounding lug. Tighten the grounding lug set screw to 30 to 35 lbs-force inches (3.4 to 4.0 Nm) of torque.
- ▶ **Note:** The grounding lug provided with the cabinet can be used for #6 – #14 AWG wire.
4. Route the free end of the grounding wire to an approved earth ground source.
5. Cut the grounding wire to length and connect it to the earth ground source as specified by local code or practice.

5 PRE-INSTALLED FEEDER CABLE CONFIGURATION

The FDH 3000 indoor 432 cabinet with multi-fiber connectors is available with a pre-installed feeder cable that enters/exits the cabinet from either the top or bottom. The cable stub end must be spliced to the network feeder cable at a separate splice enclosure (not provided).

The feeder cable may have a fiber count of 24 or 48 fibers depending on the option ordered. The feeder cable is secured internally with a clamp and externally with a compression fitting. Below the clamp, the outer sheath of the cable is removed to expose the optical fiber subunits. The cable subunits are routed to the splitter compartment. Extra fibers are routed to the sliding adapter pack. The subunits are numbered and the individual fibers are color-coded for identification. A drawing showing the feeder cable routing is provided in [Figure 14](#).

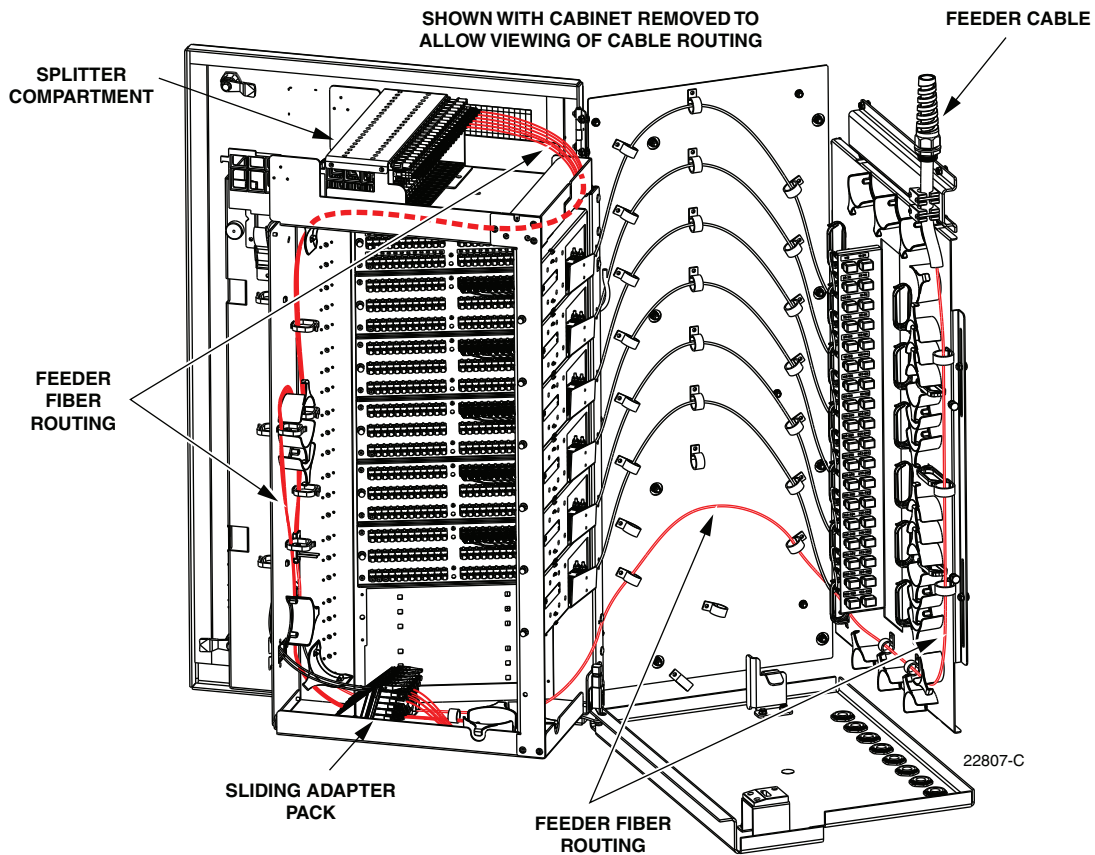

Figure 14. Feeder Cable Typical Configuration - Top Entry

6 FEEDER CABLE INSTALLATION AND SPLICING - TOP ENTRY/EXIT

The FDH 3000 indoor 432 cabinet with multi-fiber connectors may be ordered without a factory-installed feeder cable. This section describes how to install the feeder cable when the pre-installed feeder cable option was not ordered and when the cable will be installed from the **top**. Also covered are procedures for splicing the feeder cable fibers to the splitter input pigtails.

6.1 Feeder Cable Installation

A compression fitting is used to secure the cable at the entry/exit point to the cabinet. Within the cabinet, a pair of clamps secure the cable to a bracket. Beyond the clamps, the outer sheath of the cable is removed to expose the optical fibers. The feeder cable should be a 24- or 48-fiber cable and may have stranded or ribbon fiber construction. In addition, if the cabinet is equipped with brass cable clamps, the diameter of the cable should be 0.51 inches. If installing ribbon cable, use a breakout kit to protect the exposed optical fibers. Install grounding kits on cables with metallic elements. From the clamping point, the optical fibers are routed to splice trays for splicing to the splitter input pigtails.

Use the following procedure to install the feeder cable:

1. Locate the cable entry/exit hole (on top of the cabinet) that is specified for feeder cable installation as shown in [Figure 15](#).

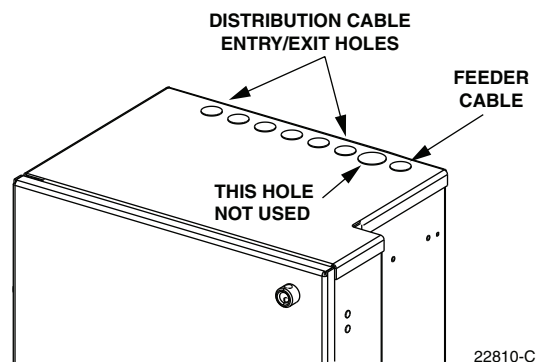

Figure 15. Cable Entry/Exit Holes

2. Open the cabinet door and swing frame to provide access to the interior of the cabinet.
3. Remove the plastic cap and retaining nut from the feeder cable entry/exit hole as shown in [Figure 16](#). Save the retaining nut for reuse.
4. Locate the spiral compression fitting components that are shipped with the cabinet and loosely assemble the fitting as shown (see [Figure 16](#)).
5. Slide the spiral compression fitting and O-ring over the end of the feeder cable. Loosen the compression fitting nut if the compression fitting does not slide freely over the cable.
6. Insert the end of the feeder cable into the cable entry/exit hole and pull through about **14 feet** (4.3 meters) of cable slack.

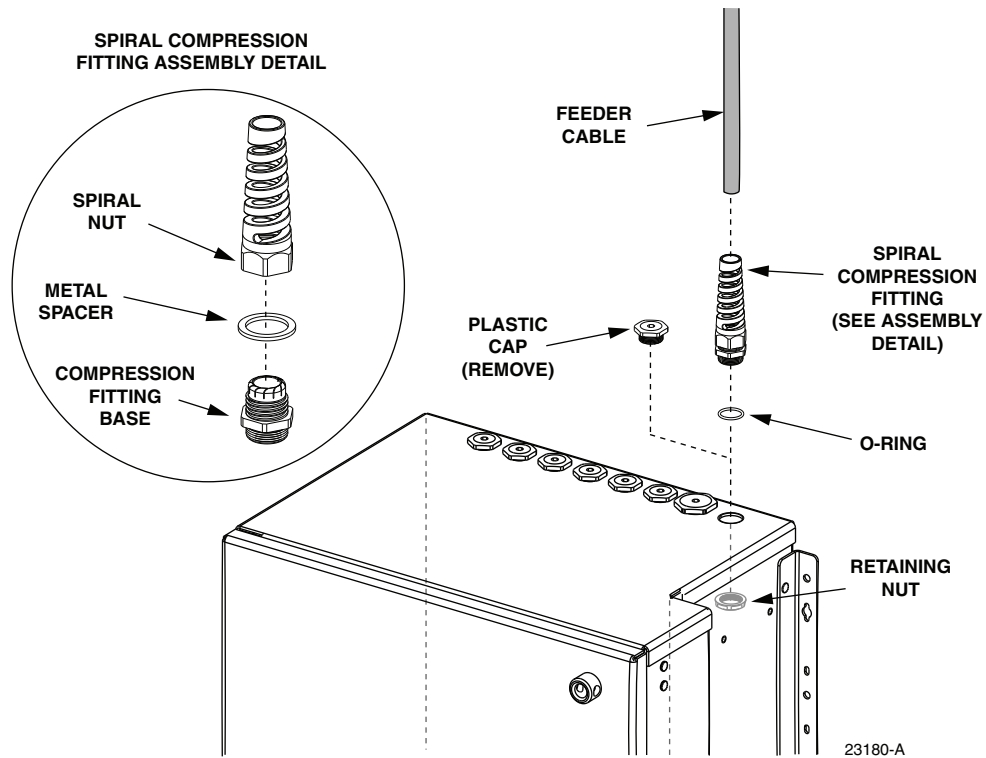

Figure 16. Plastic Cap Removal and Compression Fitting Installation

7. Slide the retaining nut (saved in step 2) over the end of the feeder cable and move it up to the cable entry/exit hole.
8. Insert the threaded end of the spiral compression fitting into the cable entry/exit hole and secure it to the cabinet with the retaining nut.
9. Strip back the feeder cable sheath **157 inches** (399 cm) to expose the fiber subunits or fiber ribbons.
10. Install breakout and grounding kits as required by local practice. Follow the installation instructions provided with each kit.
 - ▶ **Note:** A breakout kit is recommended when installing ribbon cable. The breakout kit includes plastic tubes that protect the fiber ribbons and prevent damage. Instructions for trimming the plastic tubes to length are provided in [Section 6.3](#). If a grounding kit is required, install the cable grounding clamp prior to securing the cable to the cabinet.
11. Adjust cable to remove any excess slack from the cabinet interior and then tighten the spiral compression fitting nut to secure the feeder cable at the cable entry/exit hole.
12. Depending on the cabinet option, either plastic or brass clamps will be provided with the cabinet. Assemble the cable clamps on the feeder cable as shown in [Figure 17](#).
 - ▶ **Note:** If brass cable clamps are provided with the cabinet, the diameter of the feeder cable should be **0.51 inches**.

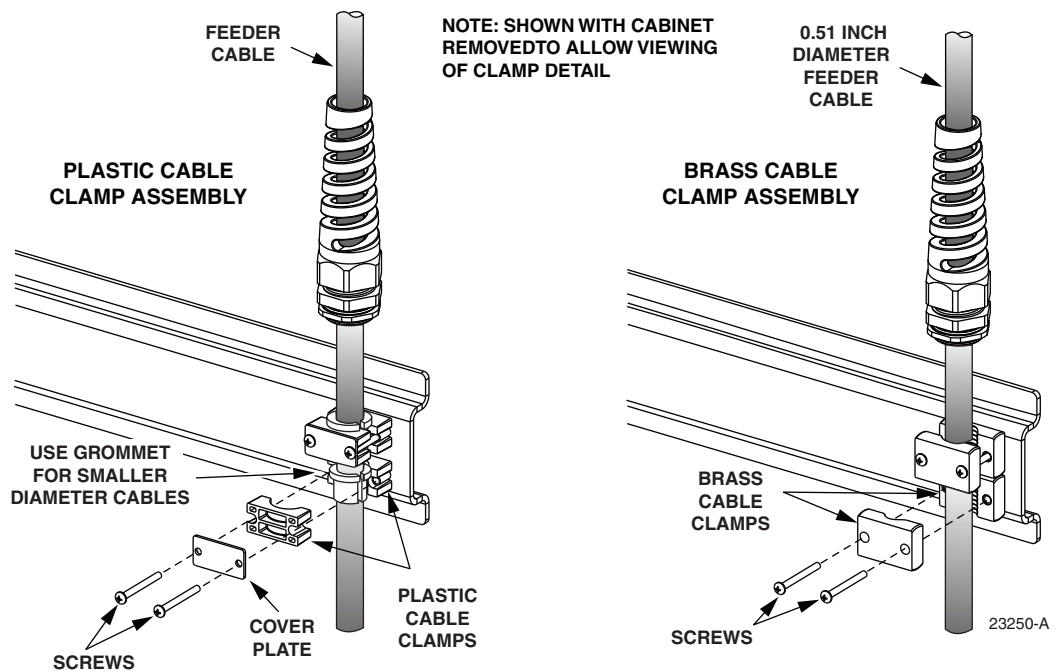

Figure 17. Assembling Feeder Cable Clamps

13. Use the two sets of cable clamps to secure the cable to the mounting strip inside the cabinet. Tighten both clamp screws evenly. If the cabinet is equipped with brass cable clamps, tighten the clamp screws until both halves of the cable clamp are touching.
14. Carefully coil the exposed feeder cable fibers around the bottom of the cabinet where they will be out of the way until ready to begin splicing.
15. If a grounding kit was installed on the feeder cable, refer to [Section 6.2](#) for connecting the grounding cable to the cabinet ground block. If a grounding kit was not required, refer to [Section 6.3](#) or [Section 6.4](#) for the splicing procedure.

6.2 Grounding Cables with Metallic Members

All cabinets are equipped with a copper block for grounding feeder cables equipped with metallic shields or strength members. The grounding block provides eight 10-32 grounding studs. If a cable requires grounding, obtain a grounding kit and use it to connect a #6 stranded copper wire to the metallic components of the cable. Follow the instructions provided with the cable grounding kit to attach the grounding wire to the cable. Use the following procedure to connect the grounding wire to the grounding block:

1. Route the cable grounding wire to the grounding block as shown in [Figure 18](#).
2. Crimp a ring terminal (not provided) onto the end of the cable grounding wire.

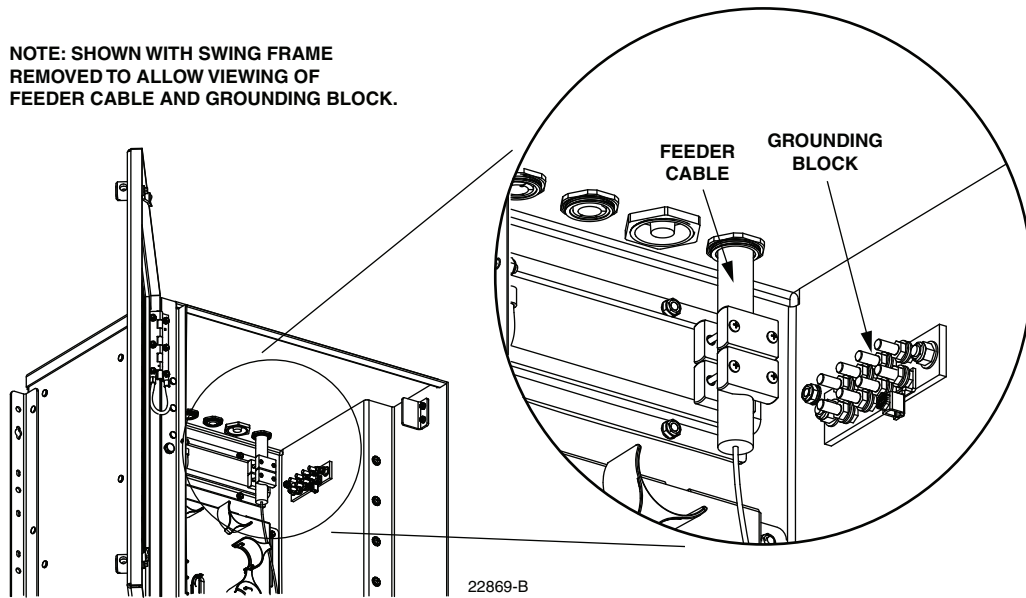

Figure 18. Location of Cable Grounding Block

3. Remove the protective plastic cap, nut, and flat washer from one of the grounding studs on the grounding block as shown in [Figure 19](#).

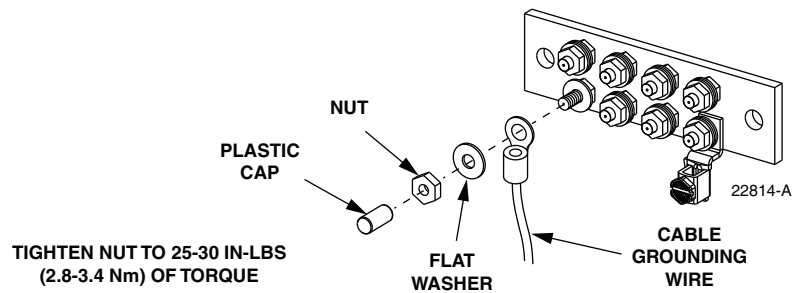

Figure 19. Connecting Grounding Cable to Grounding Block

4. Use the nut and flat washer removed in step 3 to secure the grounding wire ring terminal to the grounding block.
5. Tighten the grounding stud nut to 25 to 30 lbs-force inches (2.8 to 3.4 Nm) of torque.

6.3 Splicing the Feeder Cable Fibers to the Splitter Fibers - Ribbon Fiber

A single splice tray for splicing the feeder cable fibers to the splitter fibers is mounted on the bottom of the cabinet. The ribbon fiber splice tray can hold up to 72 splices. Use the following procedure to route and splice ribbon-type feeder cables:

1. Locate the feeder splice tray assembly which is mounted at the bottom of the cabinet, as shown in [Figure 20](#), and locate the splitter input fibers which are routed to the feeder splice tray.

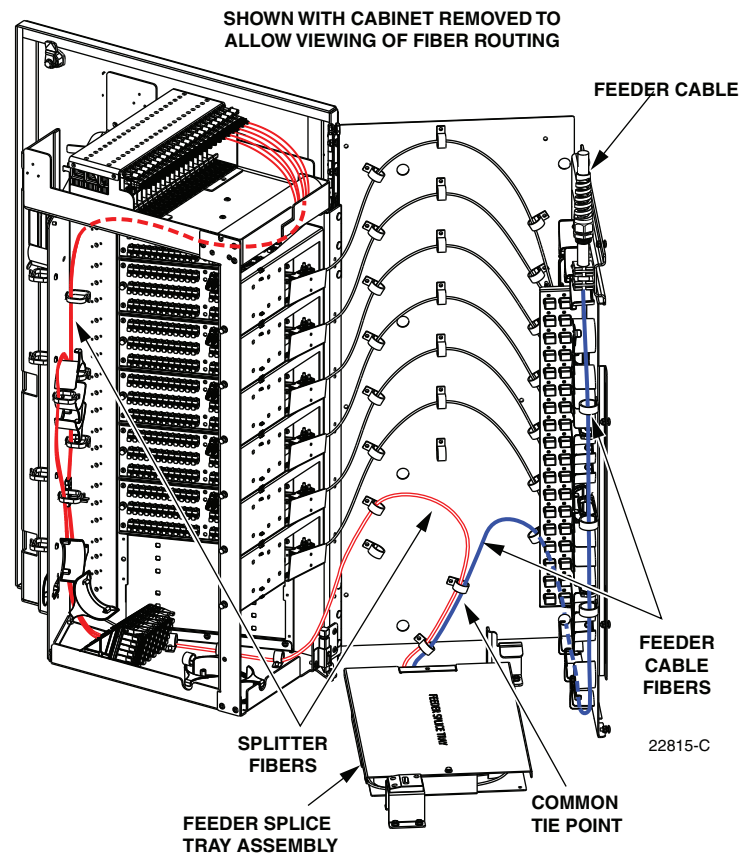

Figure 20. Feeder Splice Tray and Feeder/Splitter Fiber Routing

2. Lift the sheet metal cover away from the splice tray holder as shown in [Figure 21](#).
3. Unfasten the hook and pile strips that secure the tray in place and unwind the attached splitter fiber tubes from around the splice tray holder.
4. Beginning at the feeder cable ribbon breakout point shown in [Figure 22](#), route the protective tube or ribbon subunit to the intersect point with the splitter fibers.



Caution: Always allow sufficient fiber length to permit routing without severe bends. Non reduced bend radius fibers may be permanently damaged if bent or curved to a radius of less than 1.5 inches (3.81 cm).

5. Create a common tie point by securing the protective tube or ribbon subunit (use lacing or a cable tie) to the splitter fibers at the intersect point.
6. Route the protective tube or ribbon subunit to the splice tray and then remove the clear plastic cover from the splice tray.

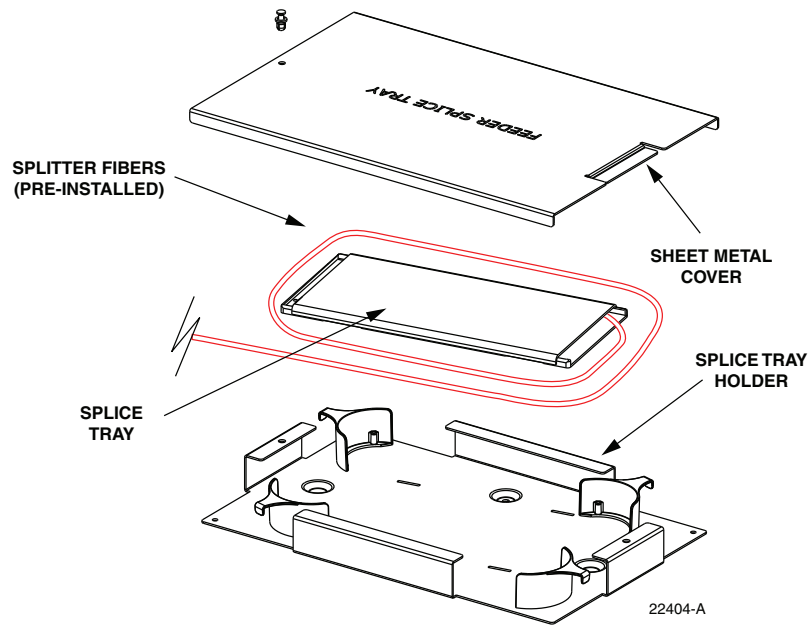

Figure 21. Feeder Slice Tray Assembly

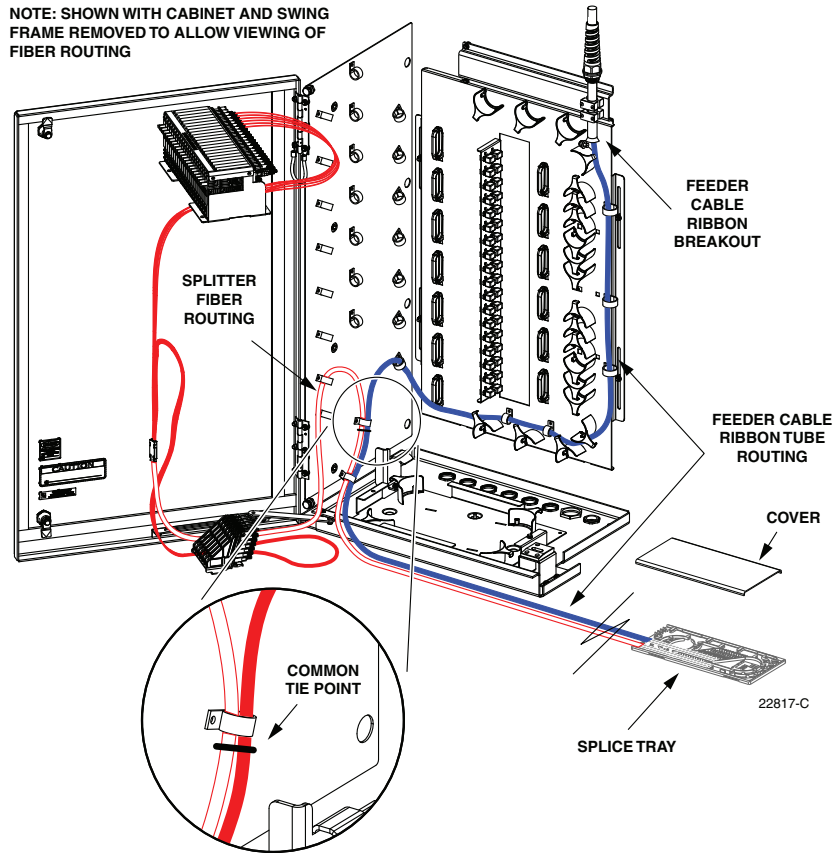

Figure 22. Feeder Fiber Routing to Splice Tray - Ribbon Cable

7. Cut the protective tube or the ribbon subunit tube (don't cut the fiber ribbons) to the **same length** as the splitter fiber tubes attached to the splice tray.
8. Use lacing or cable ties to secure the protective tube or ribbon subunit to the splice tray and verify that the feeder protective tube is the same length as the attached splitter fiber tubes. Adjust as needed to make the lengths equal.



Caution: *Improper handling can damage fiber optic cables. Do not over tighten cable ties or lacing as this can cause damage or attenuation. Do not compress the fibers or allow them to kink.*

9. From the tie point on the splice tray, trim the **feeder fibers** to a cut length of 28 inches (71 cm) and the **splitter fibers** to a cut length of 36 inches (92 cm).
10. Splice the feeder cable fibers to the appropriate splitter fibers as specified by local policies and procedures. Adjust and route the fibers within the splice tray as shown in [Figure 23](#). Refer to [Table 3](#) for the splitter fiber designations.

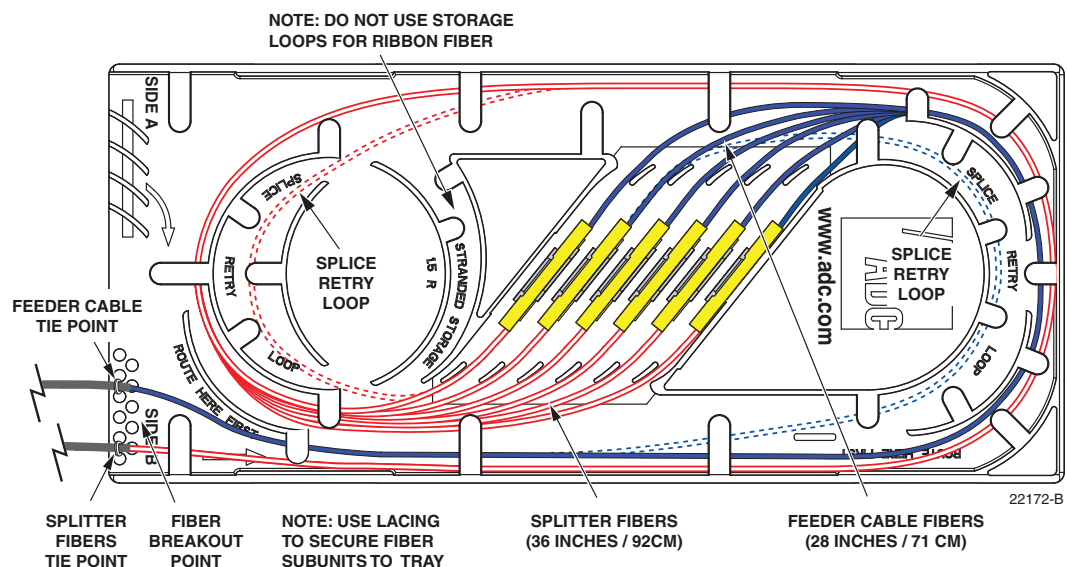

Figure 23. Ribbon Fiber Splice Tray - Feeder Cable Splicing

11. After splicing is completed, re-install the clear plastic cover on the splice tray.
12. To replace the splice tray, route the attached tubes around the splice tray holder radius limiters (there should be two service loops) as shown in [Figure 24](#). Avoid twisting or kinking the fiber tubes. Maintain a 1.5-inch (3.81 cm) minimum bend radius for all non reduced bend radius fiber.
13. Secure the splice tray to the splice tray holder using the hook and pile strips.
14. Re-install the sheet metal cover on the splice tray holder.
15. Close the swing frame and the cabinet door when splicing is finished.

Table 3. Splitter and Spare Fiber Port Designations for 12- and 48-Fiber Feeder Cables

RIBBON/SUBUNIT	FIBER	SPLITTER PORT	SPARE PORT	RIBBON/SUBUNIT	FIBER	SPLITTER PORT	SPARE PORT
1	1 (Blue)	1	–	3	1 (Blue)	–	25
	2 (Orange)	2	–		2 (Orange)	–	26
	3 (Green)	3	–		3 (Green)	–	27
	4 (Brown)	4	–		4 (Brown)	–	28
	5 (Slate)	5	–		5 (Slate)	–	29
	6 (White)	6	–		6 (White)	–	30
	7 (Red)	7	–		7 (Red)	–	31
	8 (Black)	8	–		8 (Black)	–	32
	9 (Yellow)	9	–		9 (Yellow)	–	33
	10 (Violet)	10	–		10 (Violet)	–	34
	11 (Rose)	11	–		11 (Rose)	–	35
	12 (Aqua)	12	–		12 (Aqua)	–	36
2	1 (Blue)	13	–	4	1 (Blue)	–	37
	2 (Orange)	14	–		2 (Orange)	–	38
	3 (Green)	15	–		3 (Green)	–	39
	4 (Brown)	16	–		4 (Brown)	–	40
	5 (Slate)	17	–		5 (Slate)	–	41
	6 (White)	18	–		6 (White)	–	42
	7 (Red)	19	–		7 (Red)	–	43
	8 (Black)	20	–		8 (Black)	–	44
	9 (Yellow)	21	–		9 (Yellow)	–	45
	10 (Violet)	22	–		10 (Violet)	–	46
	11 (Rose)	–	23		11 (Rose)	–	47
	12 (Aqua)	–	24		12 (Aqua)	–	48

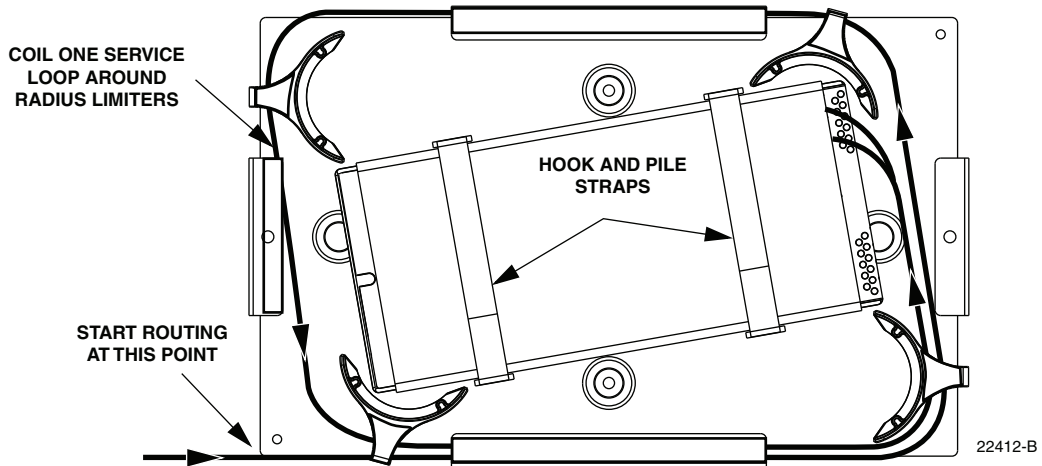

Figure 24. Feeder Splice Tray Replacement

6.4 Splicing the Feeder Cable Fibers to the Splitter Fibers - Stranded Fiber

A splice tray for splicing the feeder cable fibers to the splitter fibers is mounted on the bottom of the cabinet. The stranded fiber splice tray can hold up to 36 splices. Use the following procedure to route and splice stranded-type feeder cables:

1. Locate the feeder splice tray which is mounted at the bottom of the cabinet, as shown in [Figure 25](#), and locate the splitter fibers which are routed to the feeder splice tray.

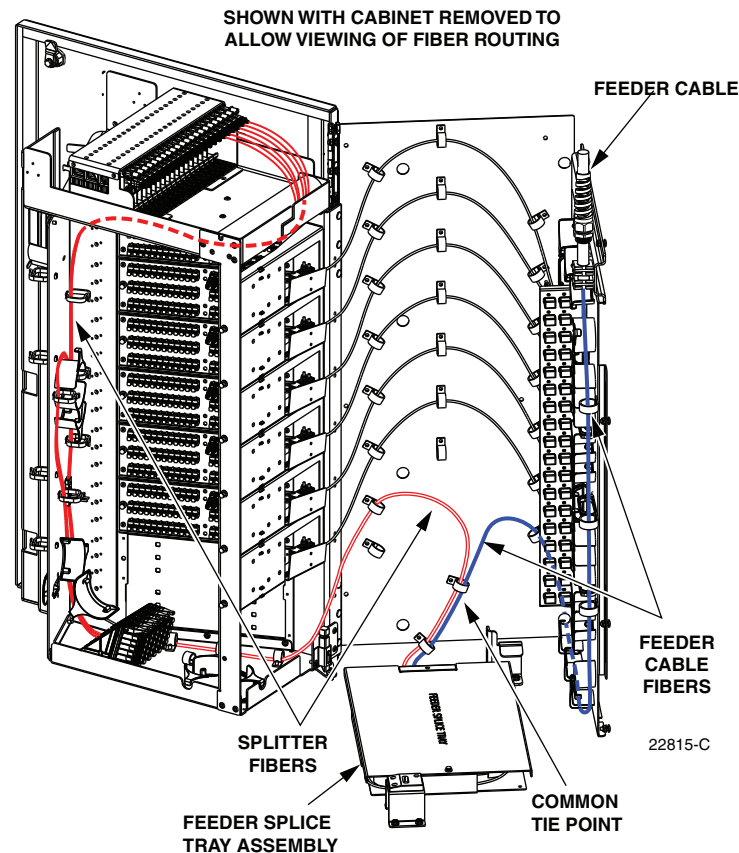

Figure 25. Feeder Splice Tray and Feeder/Splitter Fiber Routing

2. Lift the sheet metal cover (See [Figure 21](#)) away from the splice tray holder.
3. Unfasten the hook and pile strips that secure the tray in place and unwind the attached splitter fibers from around the splice tray assembly.
4. Beginning at the feeder cable subunit breakout point shown in [Figure 26](#), route the feeder cable fibers to the intersect point with the splitter fibers.



Caution: Always allow sufficient fiber length to permit routing without severe bends. Non reduced bend radius fibers may be permanently damaged if bent or curved to a radius of less than 1.5 inches (3.81 cm).

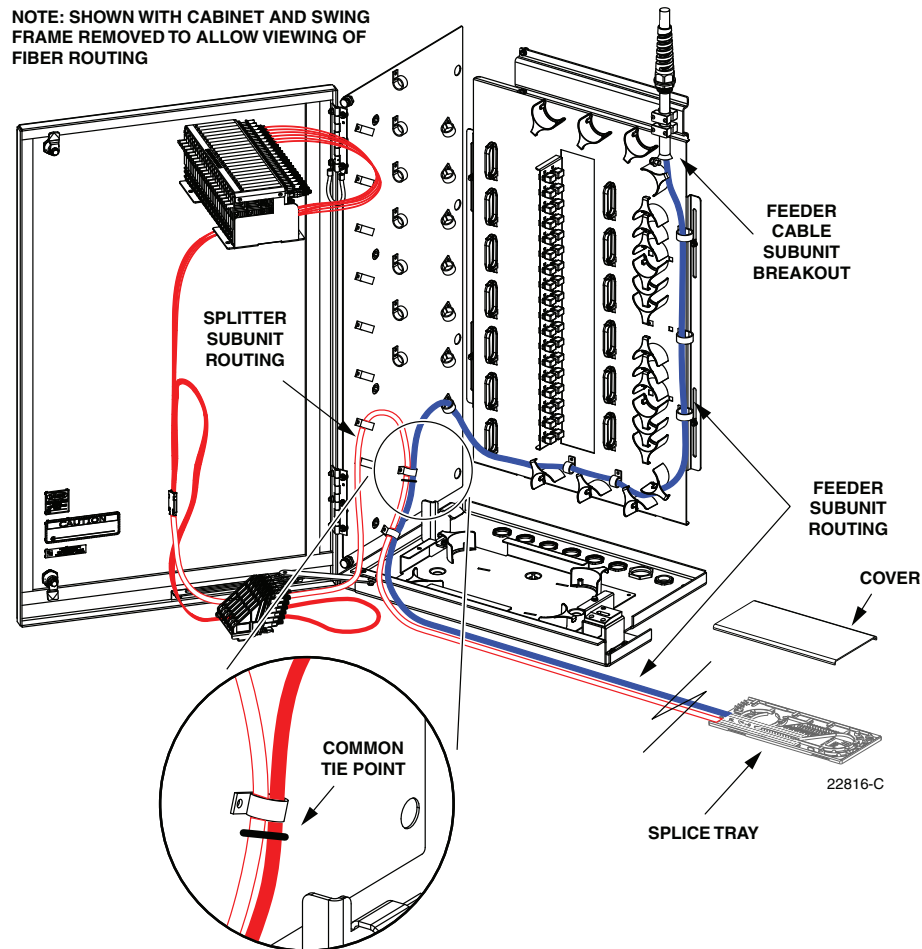

Figure 26. Feeder Fiber Routing To Splice Tray - Stranded Cable

5. Create a common tie point by securing the feeder cable subunits (use lacing or cable ties) to the splitter subunits at the intersect point.
6. Route the feeder cable subunits to the splice tray and then remove the clear plastic cover from the splice tray.
7. Use lacing or cable ties to secure the feeder cable subunits to the splice tray and verify that the feeder subunits are the same length as the attached splitter subunits. Adjust as needed to make the lengths equal.



Caution: *Improper handling can damage fiber optic cables. Do not over tighten cable ties or lacing as this can cause damage or attenuation. Do not compress the fibers or allow them to kink.*

8. From the tie point on the splice tray, trim the **feeder cable fibers** to a cut length of 28 inches (71 cm) and the **splitter fibers** to a cut length of 36 inches (92 cm).
9. Within the splice tray, remove the subunit tubes from the distribution cable fibers to expose the bare individual optical fibers.

10. Splice the feeder cable fibers to the appropriate splitter fibers as specified by local policies and procedures. Adjust and route the fibers within the splice tray as shown in [Figure 27](#). Refer to [Table 3](#) for the splitter fiber designations.

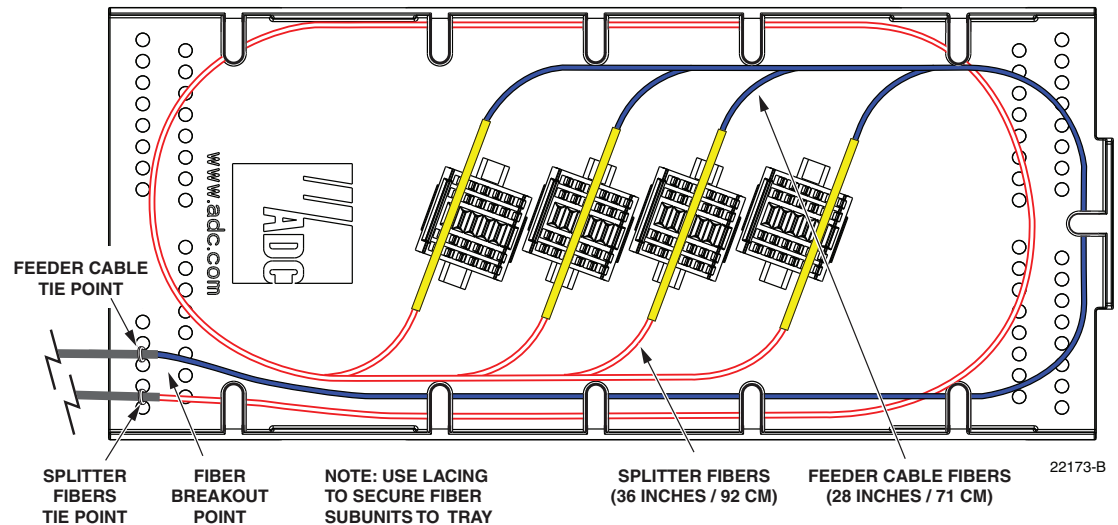

Figure 27. Stranded Fiber Splice Tray - Feeder Cable Splicing

11. After splicing is completed, re-install the clear plastic cover on the splice tray.
12. To replace the splice tray, route the attached subunits (there should be two service loops) around the splice tray holder radius limiters (see [Figure 24](#)). Avoid twisting or kinking the fiber subunit tubes. Maintain a 1.5-inch (3.81 cm) minimum bend radius for all non reduced bend radius fiber.
13. Secure the splice tray to the splice tray holder using the hook and pile strips.
14. Re-install the sheet metal cover on the splice tray holder.
15. Close the swingframe and the cabinet door when splicing is finished.

7 FEEDER CABLE INSTALLATION AND SPLICING - BOTTOM ENTRY/EXIT

The FDH 3000 indoor 432 cabinet with multi-fiber connectors may be ordered without a factory-installed indoor/outdoor (I/O) feeder cable. This section describes how to install the feeder cable when the pre-installed feeder cable option was not ordered and when the cable will be installed from the **bottom**. Also covered are procedures for splicing the feeder cable fibers to the splitter input pigtails.

7.1 Bottom Entry/Exit Feeder Cable Installation

A compression fitting is used to secure the feeder cable at the entry/exit point to the cabinet. Within the cabinet, a pair of clamps secure the cable to the inside of the cabinet. Beyond the clamps, the outer sheath of the cable is removed to expose the optical fibers. The feeder cable is typically a 12-, 24-, or 48-fiber I/O cable with stranded or ribbon fiber construction. Breakout kits should be installed to protect the exposed optical fibers and grounding kits should be installed on cables with metallic elements. From the clamping point, the optical fibers are routed to splice trays for splicing to the splitter input pigtails.

Use the following procedure to install a bottom entry/exist feeder cable:

1. Open the cabinet door and swing frame to provide access to the interior of the cabinet.
2. Locate the grounding block that is mounted on the upper right side of the cabinet as shown in [Figure 28](#).

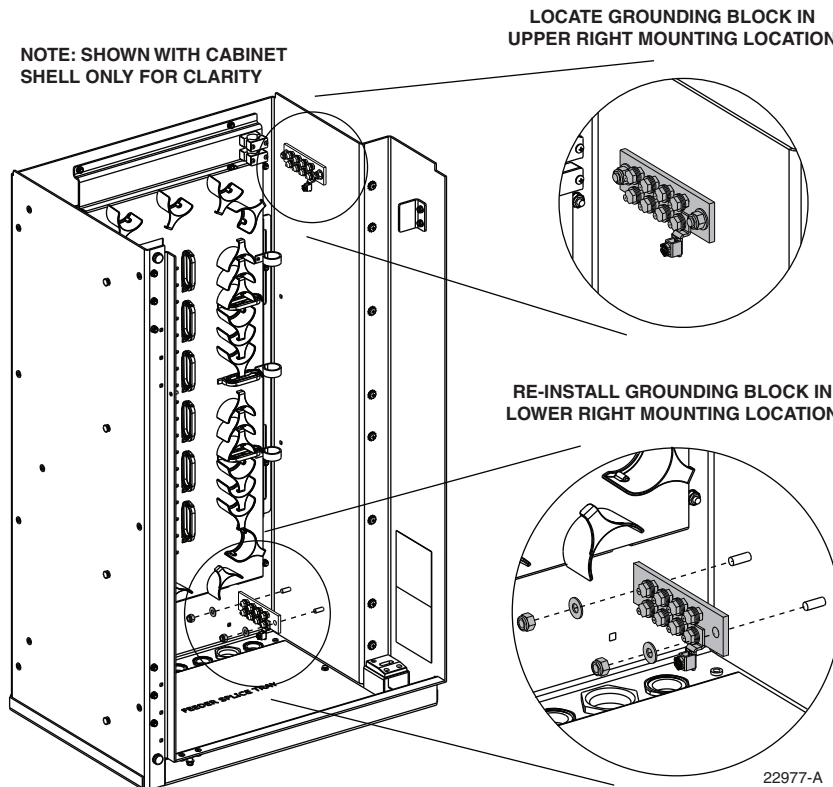

Figure 28. Grounding Block Relocation

3. Remove the nuts and washers that secure the grounding block to the cabinet.
4. Re-install the grounding block on the lower right side of the cabinet (see [Figure 28](#)) using the nuts and washers removed in step 3.
5. Locate the cable clamp bracket that is mounted at the upper back side of the cabinet as shown in [Figure 29](#).

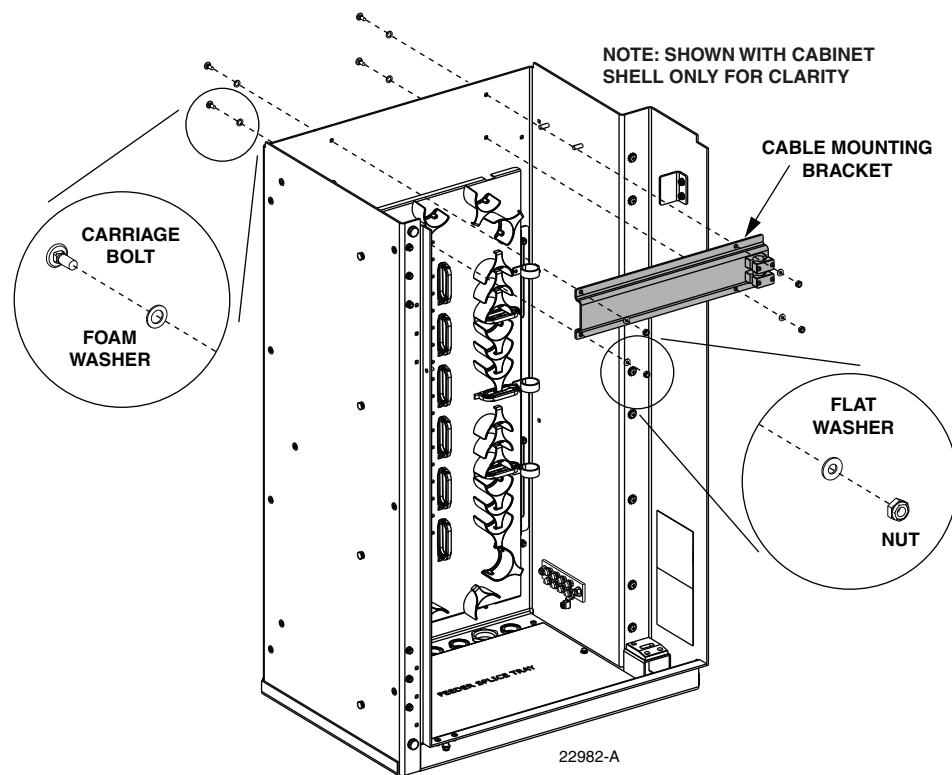

Figure 29. Locate and Remove Cable Mounting Bracket

6. Remove the carriage bolts, foam washers, flat washers, and nuts that secure the cable mounting bracket to the cabinet.
 7. Remove the cable mounting bracket from the cabinet (see [Figure 29](#)).
 8. Reinstall the carriage bolts, foam washers (use new washers), flat washers, and nuts in the holes from which they were removed.
- **Note:** Replace all used foam washers with new foam washers when reinstalling fasteners.
9. Loosen the four nuts that secure the bulkhead adapter panel to the back of the cabinet as shown in [Figure 30](#).
 10. Move the bulkhead adapter panel up to the limit of its travel and then retighten the four nuts that secure the panel to the cabinet.

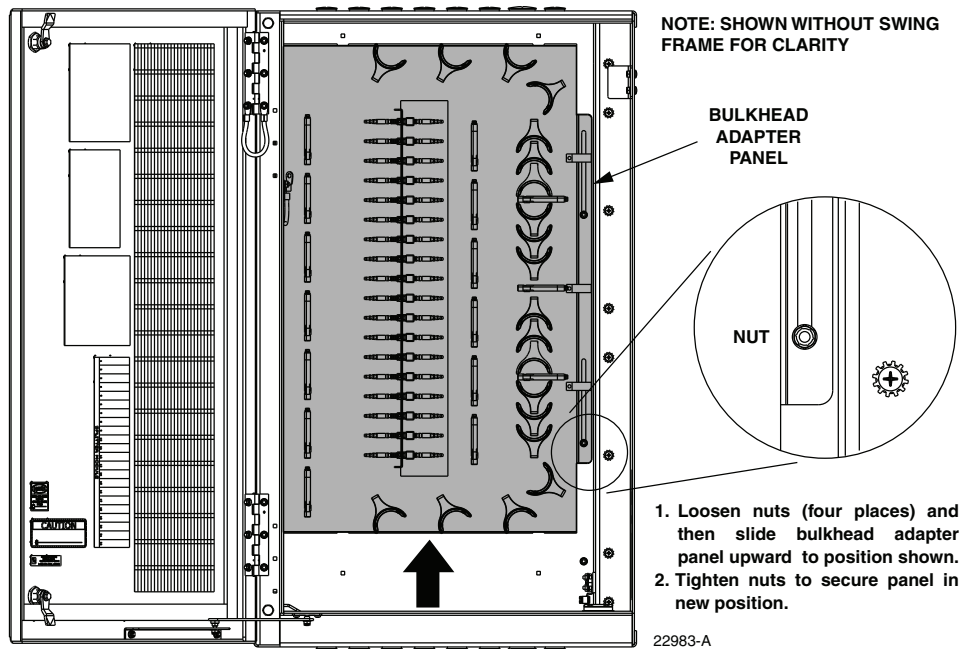

Figure 30. Reposition Bulkhead Adapter Panel

11. Remove the specified carriage bolts, foam washers, flat washers, and nuts from the lower half of the cabinet as shown in [Figure 31](#).

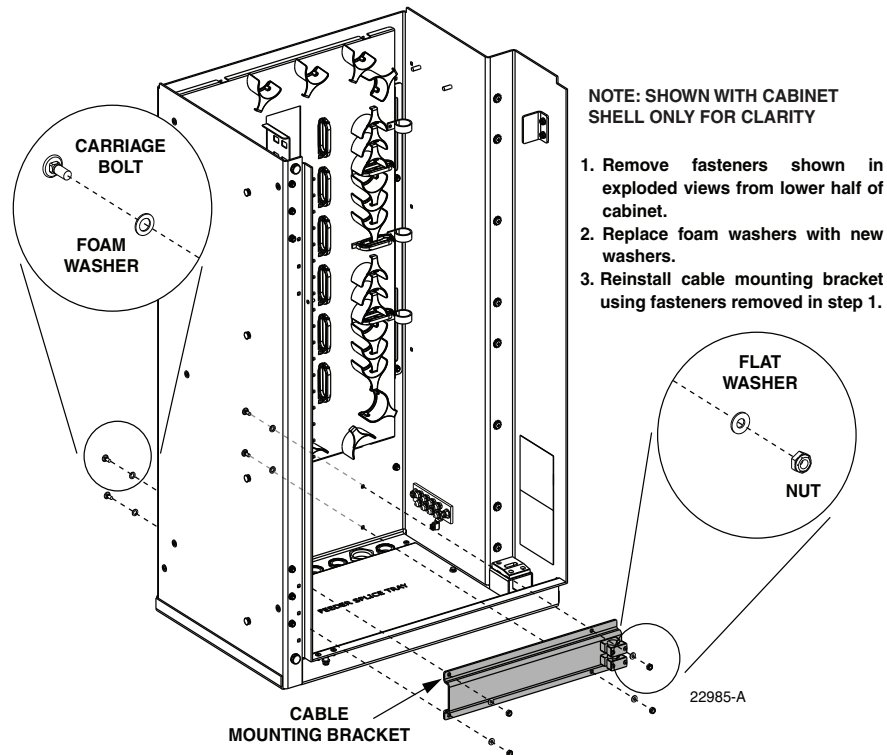

Figure 31. Reinstall Cable Mounting Bracket

12. Reinstall the cable mounting bracket (removed in step 7) in the lower half of the cabinet using the fasteners removed in step 11.
- ▶ **Note:** Replace all used foam washers with new foam washers when reinstalling fasteners.
13. Locate the cable entry/exit hole (on the bottom of the cabinet) that is specified for feeder cable installation as shown in [Figure 32](#).

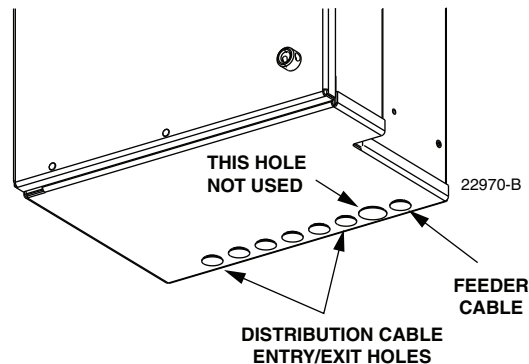

Figure 32. Feeder Cable Bottom Entry/Exit Hole

14. Remove the plastic cap and retaining nut from the feeder cable entry/exit hole as shown in [Figure 33](#). Save the retaining nut for reuse.
15. Locate the spiral compression fitting components that are shipped with the cabinet and loosely assemble the fitting as shown ([Figure 33](#)).

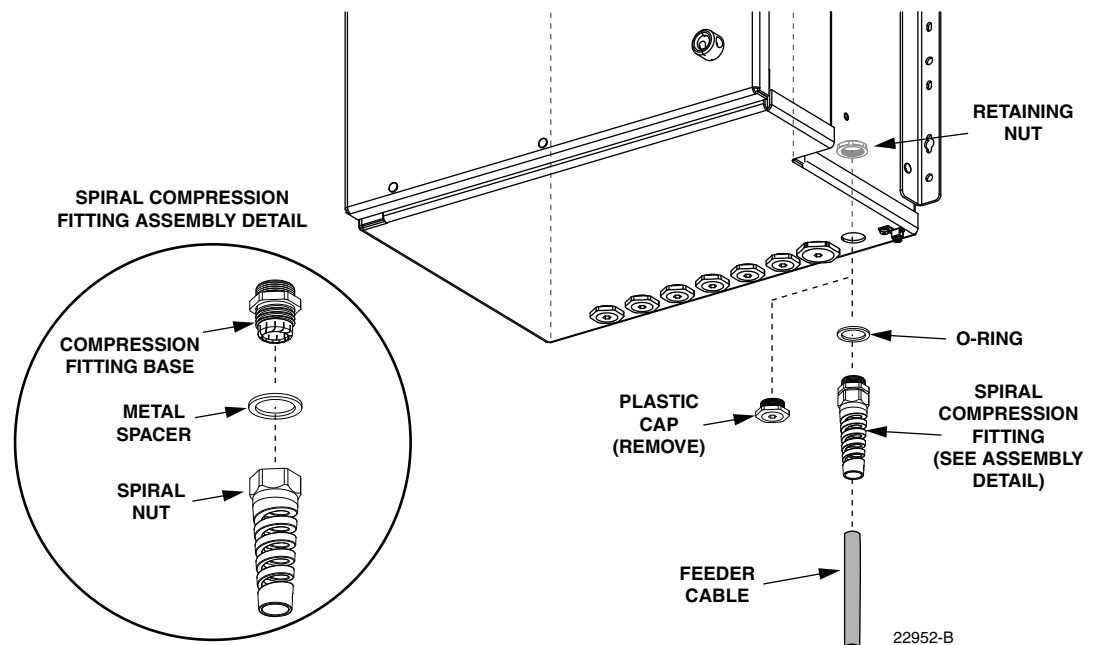

Figure 33. Plastic Cap Removal and Compression Fitting Installation

16. Slide the spiral compression fitting and O-ring over the end of the feeder cable. Loosen the compression fitting nut if the compression fitting does not slide freely over the cable.
17. Insert the end of the feeder cable into the cable entry/exit hole and pull through about **14 feet** (4.3 meters) of cable slack.
18. Slide the retaining nut (saved in step 2) over the end of the feeder cable and move it up to the cable entry/exit hole.
19. Insert the threaded end of the spiral compression fitting into the cable entry/exit hole and secure it to the cabinet with the retaining nut.
20. Strip back the feeder cable sheath **157 inches** (399 cm) to expose the fiber subunits or fiber ribbons.
21. Install breakout and grounding kits as required by local practice. Follow the installation instructions provided with each kit.
 - ▶ **Note:** A breakout kit is recommended when installing ribbon cable. The breakout kit includes plastic tubes that protect the fiber ribbons and prevent damage. Instructions for trimming the plastic tubes to length are provided in [Section 6.3](#). If a grounding kit is required, install the cable grounding clamp prior to securing the cable to the cabinet.
22. Adjust cable to remove any excess slack from the cabinet interior and then tighten the spiral compression fitting nut to secure the feeder cable at the cable entry/exit hole.
23. Depending on the cabinet option, either plastic or brass clamps will be provided with the cabinet. Assemble the cable clamps on the feeder cable as shown in [Figure 34](#).
 - ▶ **Note:** If brass cable clamps are provided with the cabinet, the diameter of the feeder cable should be **0.51 inches** or the brass clamps will not retain the cable properly.

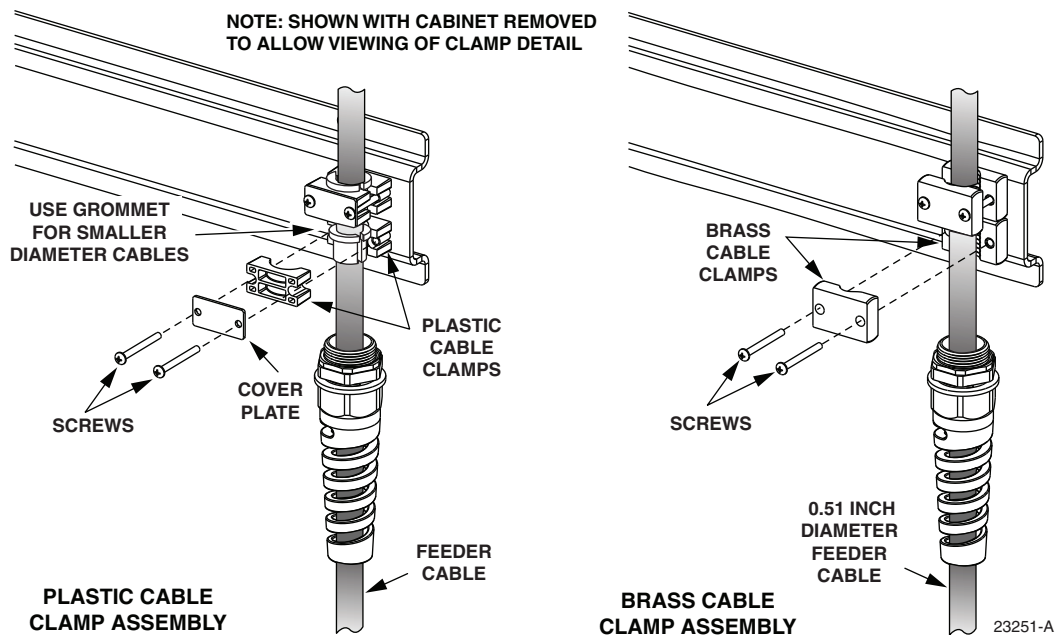

Figure 34. Assembling Feeder Cable Clamps

24. Use the two sets of cable clamps to secure the cable to the mounting strip inside the cabinet. Tighten both clamp screws evenly. If the cabinet is equipped with brass cable clamps, tighten the clamp screws until both halves of the cable clamp are touching.
25. Carefully coil the exposed feeder cable fibers around the bottom of the cabinet where they will be out of the way until ready to begin splicing.
26. If a grounding kit was installed on the feeder cable, refer to [Section 6.2](#) for connecting the grounding cable to the cabinet ground block. If a grounding kit was not required, refer to [Section 6.3](#) or [Section 6.4](#) for the splicing procedure.

7.2 Grounding Cables with Metallic Members

All cabinets are equipped with a copper block for grounding feeder cables equipped with metallic shields or strength members. The grounding block, shown in [Figure 35](#), provides eight 10-32 grounding studs. If a cable requires grounding, connect a #6 stranded copper wire to the metallic components of the cable. Follow the instructions provided with the cable grounding kit to attach the grounding wire to the cable. Use the following procedure to connect the grounding wire to the grounding block:

1. Route the cable grounding wire to the grounding block.
2. Crimp a ring terminal (not provided) onto the end of the cable grounding wire.

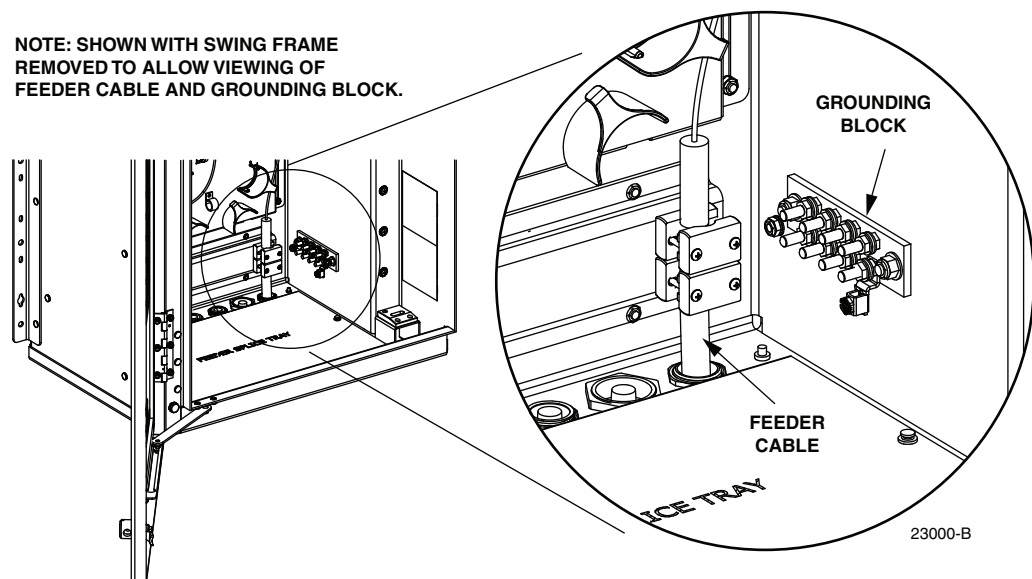

Figure 35. Location of Cable Grounding Block

3. Remove the protective plastic cap, nut, and flat washer from one of the grounding studs on the grounding block as shown in [Figure 36](#).
4. Use the nut and flat washer removed in step 3 to secure the grounding wire ring terminal to the grounding block.
5. Tighten the grounding stud nut to 25 to 30 lbs-force inches (2.8 to 3.4 Nm) of torque.

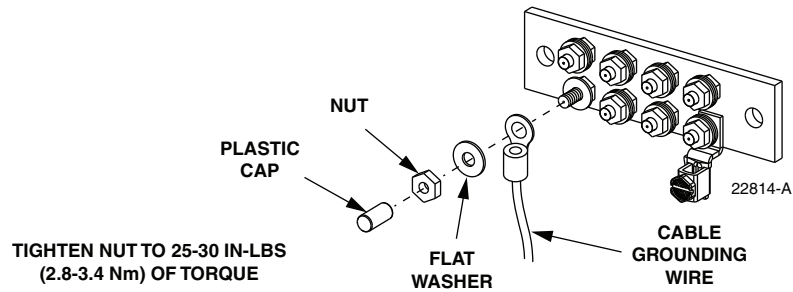

Figure 36. Connecting Grounding Cable to Grounding Block

7.3 Splicing the Feeder Cable Fibers to the Splitter Fibers - Ribbon Fiber

A single splice tray for splicing the feeder cable fibers to the splitter fibers is mounted on the bottom of the cabinet. The ribbon fiber splice tray can hold up to 72 splices. Use the following procedure to route and splice ribbon-type feeder cables:

1. Locate the feeder splice tray assembly mounted at the bottom of the cabinet, as shown in [Figure 37](#), and locate the splitter input fibers which are routed to the feeder splice tray.

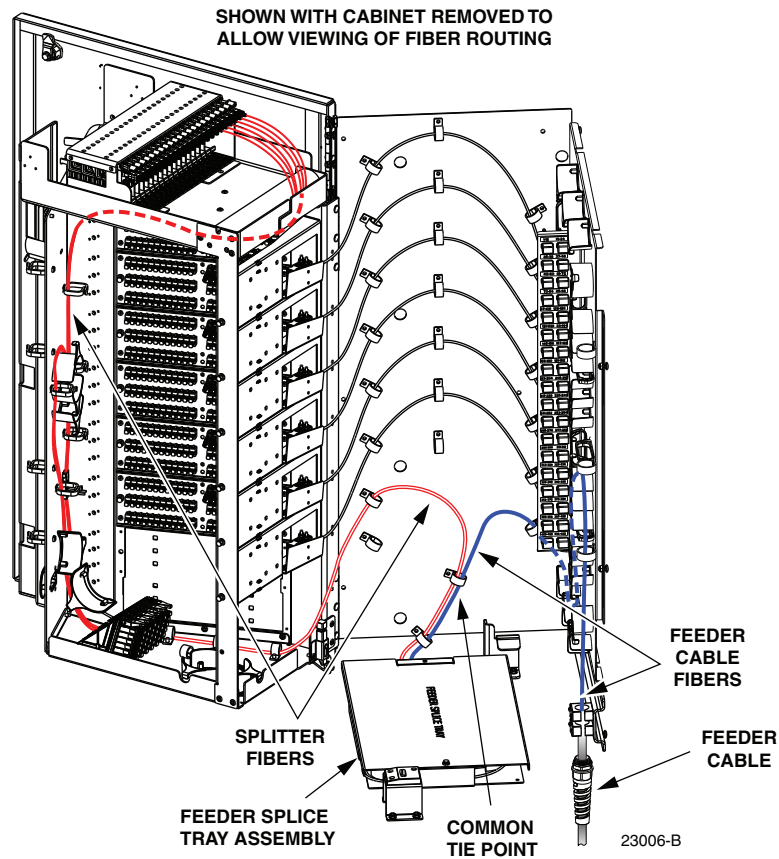

Figure 37. Feeder Splice Tray and Feeder/Splitter Fiber Routing

- Lift the sheet metal cover away from the splice tray holder as shown in [Figure 38](#).

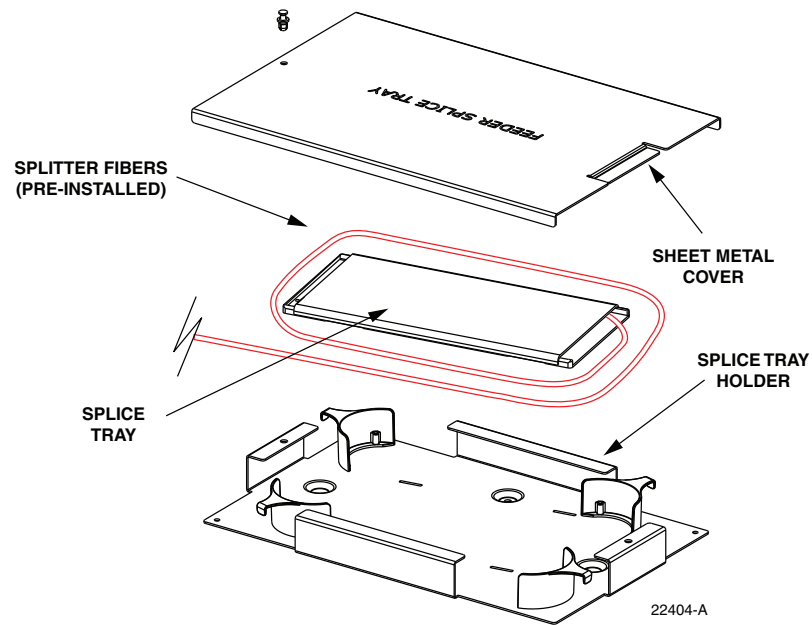

Figure 38. Feeder Slice Tray Assembly

- Unfasten the hook and pile strips that secure the tray in place and unwind the attached splitter fiber tubes from around the splice tray holder.
- Beginning at the feeder cable ribbon breakout point shown in [Figure 39](#), route the protective tube or ribbon subunit to the intersect point with the splitter fibers.



Caution: Always allow sufficient fiber length to permit routing without severe bends. Non reduced bend radius fibers may be permanently damaged if bent or curved to a radius of less than 1.5 inches (3.81 cm).

- Create a common tie point by securing the protective tube or ribbon subunit (use lacing or a cable tie) to the splitter fibers at the intersect point.
- Route the protective tube or ribbon subunit to the splice tray and then remove the clear plastic cover from the splice tray.
- Cut the protective tube or the ribbon subunit tube (don't cut the fiber ribbons) to the **same length** as the splitter fiber tubes attached to the splice tray.

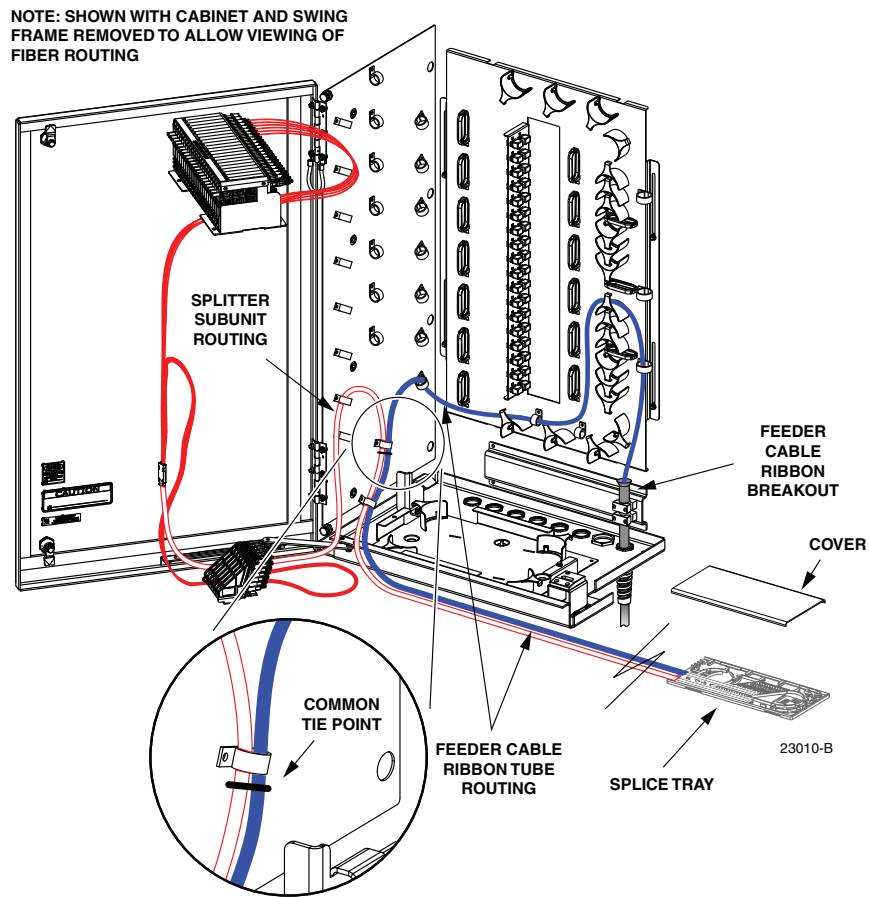

Figure 39. Feeder Fiber Routing to Splice Tray - Ribbon Cable

8. Use lacing or cable ties to secure the protective tube or ribbon subunit to the splice tray and verify that the feeder protective tube is the same length as the attached splitter fiber tubes. Adjust as needed to make the lengths equal.



Caution: *Improper handling can damage fiber optic cables. Do not over tighten cable ties or lacing as this can cause damage or attenuation. Do not compress the fibers or allow them to kink.*

9. From the tie point on the splice tray, trim the **feeder fibers** to a cut length of 28 inches (71 cm) and the **splitter fibers** to a cut length of 36 inches (92 cm).
10. Splice the feeder cable fibers to the appropriate splitter fibers as specified by local policies and procedures. Adjust and route the fibers within the splice tray as shown in [Figure 40](#). Refer to [Table 4](#) for the splitter fiber designations.
11. After splicing is completed, re-install the clear plastic cover on the splice tray.

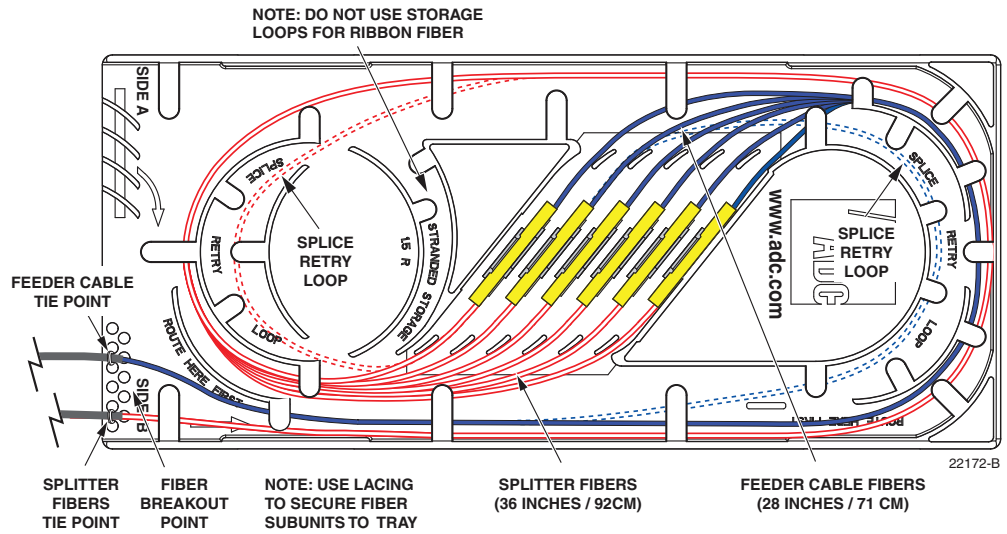

Figure 40. Ribbon Fiber Splice Tray - Feeder Cable Splicing

Table 4. Splitter and Spare Fiber Port Designations for 12- and 48-Fiber Feeder Cables

RIBBON/SUBUNIT	FIBER	SPLITTER PORT	SPARE PORT	RIBBON/SUBUNIT	FIBER	SPLITTER PORT	SPARE PORT
1	1 (Blue)	1	–	3	1 (Blue)	–	25
	2 (Orange)	2	–		2 (Orange)	–	26
	3 (Green)	3	–		3 (Green)	–	27
	4 (Brown)	4	–		4 (Brown)	–	28
	5 (Slate)	5	–		5 (Slate)	–	29
	6 (White)	6	–		6 (White)	–	30
	7 (Red)	7	–		7 (Red)	–	31
	8 (Black)	8	–		8 (Black)	–	32
	9 (Yellow)	9	–		9 (Yellow)	–	33
	10 (Violet)	10	–		10 (Violet)	–	34
	11 (Rose)	11	–		11 (Rose)	–	35
	12 (Aqua)	12	–		12 (Aqua)	–	36
2	1 (Blue)	13	–	4	1 (Blue)	–	37
	2 (Orange)	14	–		2 (Orange)	–	38
	3 (Green)	15	–		3 (Green)	–	39
	4 (Brown)	16	–		4 (Brown)	–	40
	5 (Slate)	17	–		5 (Slate)	–	41
	6 (White)	18	–		6 (White)	–	42
	7 (Red)	19	–		7 (Red)	–	43
	8 (Black)	20	–		8 (Black)	–	44
	9 (Yellow)	21	–		9 (Yellow)	–	45
	10 (Violet)	22	–		10 (Violet)	–	46
	11 (Rose)	–	23		11 (Rose)	–	47
	12 (Aqua)	–	24		12 (Aqua)	–	48

12. To replace the splice tray, route the attached tubes around the splice tray holder radius limiters (there should be two service loops) as shown in [Figure 41](#). Avoid twisting or kinking the fiber tubes. Maintain a 1.5-inch (3.81 cm) minimum bend radius for all non reduced bend radius fiber.

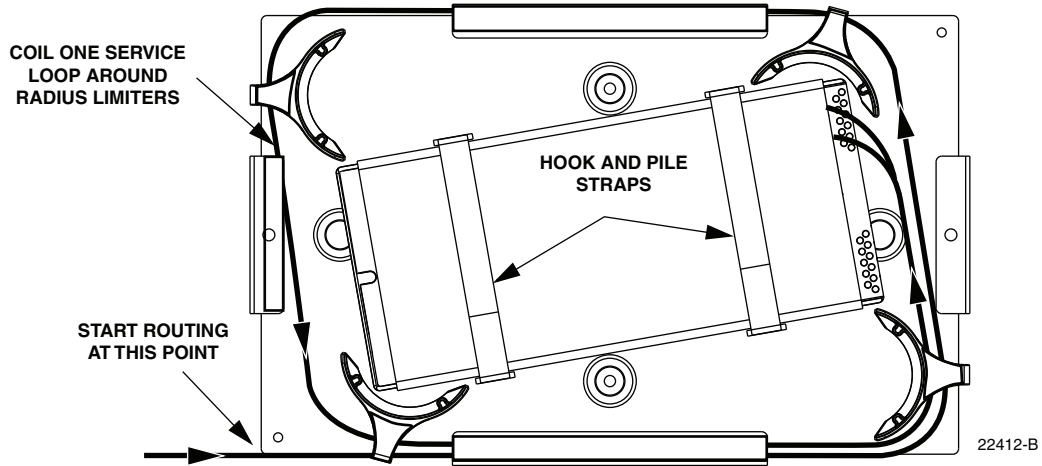

Figure 41. Feeder Splice Tray Replacement

13. Secure the splice tray to the splice tray holder using the hook and pile strips.
14. Re-install the sheet metal cover on the splice tray holder.
15. Close the swing frame and the cabinet door when splicing is finished.

7.4 Splicing the Feeder Cable Fibers to the Splitter Fibers - Stranded Fiber

A splice tray for splicing the feeder cable fibers to the splitter fibers is mounted on the bottom of the cabinet. The stranded fiber splice tray can hold up to 36 splices. Use the following procedure to route and splice stranded-type feeder cables:

1. Locate the feeder splice tray which is mounted at the bottom of the cabinet, as shown in [Figure 42](#), and locate the splitter fibers which are routed to the feeder splice tray.
2. Lift the sheet metal cover (See [Figure 38](#)) away from the splice tray holder.
3. Unfasten the hook and pile strips that secure the tray in place and unwind the attached splitter fibers from around the splice tray assembly.

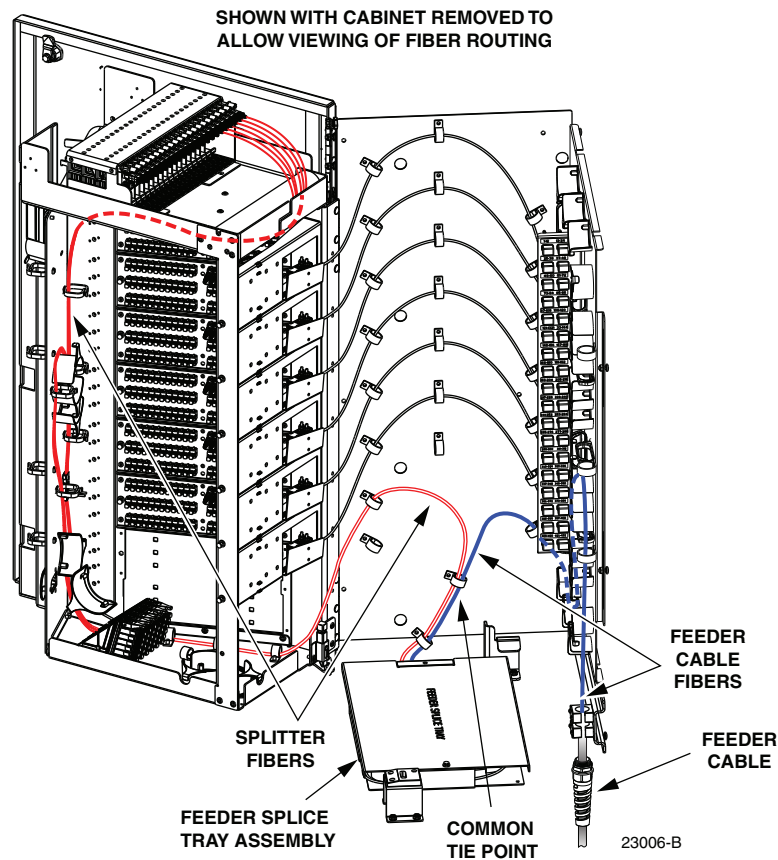

Figure 42. Feeder Splice Tray and Feeder/Splitter Fiber Routing

4. Beginning at the feeder cable subunit breakout point shown in [Figure 43](#), route the feeder cable fibers to the intersect point with the splitter fibers.



Caution: Always allow sufficient fiber length to permit routing without severe bends. Non reduced bend radius fibers may be permanently damaged if bent or curved to a radius of less than 1.5 inches (3.81 cm).

5. Create a common tie point by securing the feeder cable subunits (use lacing or cable ties) to the splitter subunits at the intersect point.
6. Route the feeder cable subunits to the splice tray and then remove the clear plastic cover from the splice tray.
7. Use lacing or cable ties to secure the feeder cable subunits to the splice tray and verify that the feeder subunits are the same length as the attached splitter subunits. Adjust as needed to make the lengths equal.



Caution: Improper handling can damage fiber optic cables. Do not over tighten cable ties or lacing as this can cause damage or attenuation. Do not compress the fibers or allow them to kink.

8. From the tie point on the splice tray, trim the **feeder cable fibers** to a cut length of 28 inches (71 cm) and the **splitter fibers** to a cut length of 36 inches (92 cm).

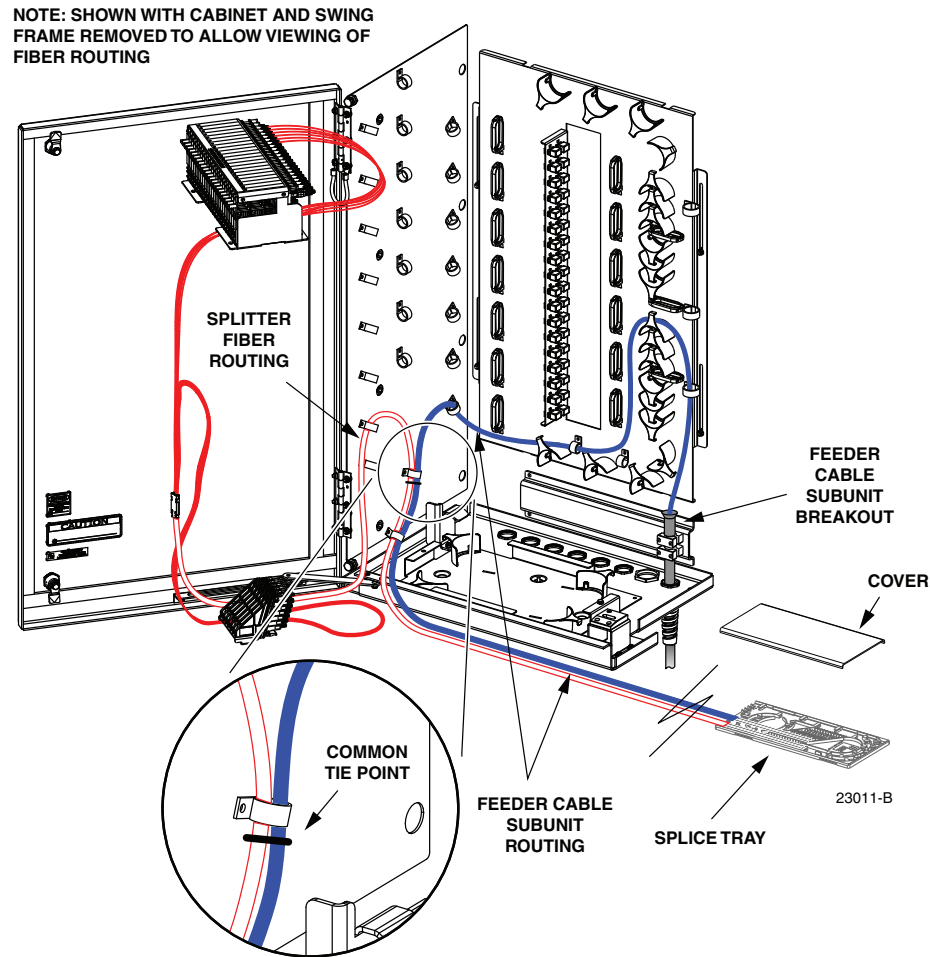

Figure 43. Feeder Fiber Routing To Splice Tray - Stranded Cable

9. Within the splice tray, remove the subunit tubes from the distribution cable fibers to expose the bare individual optical fibers.
10. Splice the feeder cable fibers to the appropriate splitter fibers as specified by local policies and procedures. Adjust and route the fibers within the splice tray as shown in [Figure 44](#). Refer to [Table 4](#) for the splitter fiber designations.
11. After splicing is completed, re-install the clear plastic cover on the splice tray.
12. To replace the splice tray, route the attached subunits (there should be two service loops) around the splice tray holder radius limiters as shown in [Figure 45](#). Avoid twisting or kinking the fiber subunit tubes. Maintain a 1.5-inch (3.81 cm) minimum bend radius for all non reduced bend radius fiber.
13. Secure the splice tray to the splice tray holder using the hook and pile strips.
14. Re-install the sheet metal cover on the splice tray holder.
15. Close the swingframe and the cabinet door when splicing is finished.

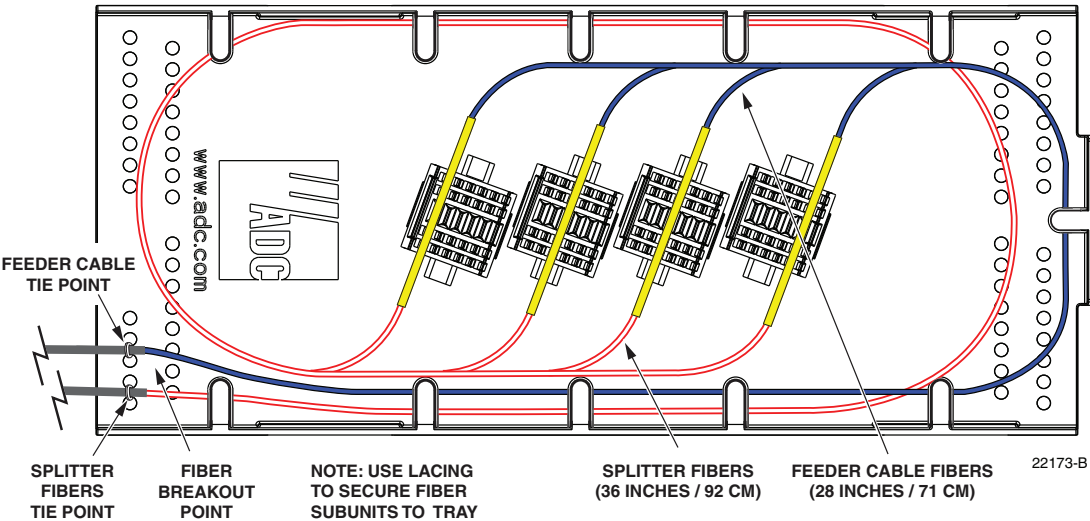

Figure 44. Stranded Fiber Splice Tray - Feeder Cable Splicing

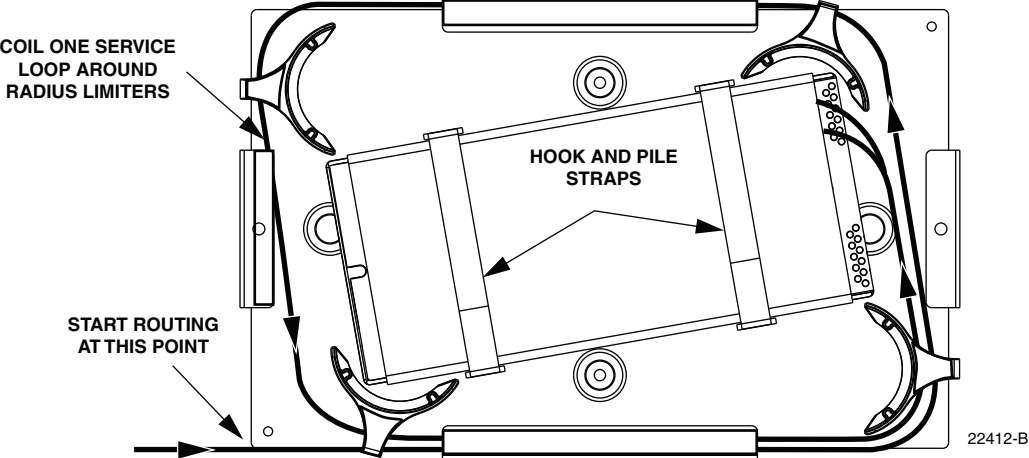

Figure 45. Feeder Splice Tray Replacement - Stranded Fiber Splicing

8 DISTRIBUTION CABLE INSTALLATION AND ROUTING - TOP ENTRY/EXIT

This section describes how to install top entry/exit distribution cables in the FDH 3000 indoor 432 cabinet with multi-fiber connectors. The distribution cables used with the cabinet must be rated for indoor use and designed for reduced bend radius applications. In addition, each distribution cable must be a 3 mm, stranded, 12-fiber cable terminated with a 12-fiber MTP® connector.

A compression-type fitting is provided for securing each distribution cable at the point where it enters the cabinet. Six 3 mm distribution cables may be routed into the cabinet through each entry/exit hole. Within the cabinet, the distribution cables are routed to the front side of the bulkhead adapter panel. Inserting the MTP® connectors into the appropriate bulkhead adapters connects the distribution cable fibers to the optical ports on the specified distribution panel.

The cabinet supports up to six distribution panels, each of which provides 72 optical ports. Each distribution panel is equipped with six 12-fiber subunits that are terminated with 12-fiber MTP® connectors. The fibers from the distribution panels are routed to the rear side of the bulkhead adapter panel where the MTP® connectors are inserted into specified bulkhead adapters.

Designation labels are provided on the cabinet doors for recording subscriber information for each distribution panel port. The labels indicate the connector number and cable number associated with each fiber port.

Use the following procedure to install top entry/exit distribution cables:

1. Locate the cable entry/exit holes (on top of the cabinet) that are specified for distribution cable installation as shown in [Figure 46](#).

► **Note:** The distribution cables should be installed in numerical order starting with cables 1–6 for panel 1, cables 7–12 for panel 2, cables 13–18 for panel 3, cables 19–24 for panel 4, cables 25–30 for panel 5, and cables 31–36 for panel 6.

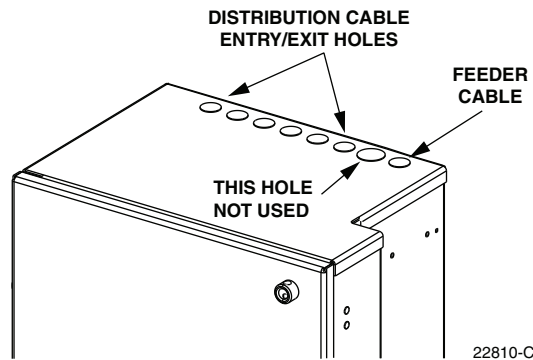

Figure 46. Distribution Cable Entry/Exit Holes

2. Open the cabinet door and swing frame to provide access to the interior of the cabinet.
3. Remove the plastic cap and retaining nut from the selected distribution cable entry/exit hole as shown in [Figure 47](#). Save the retaining nut for reuse.

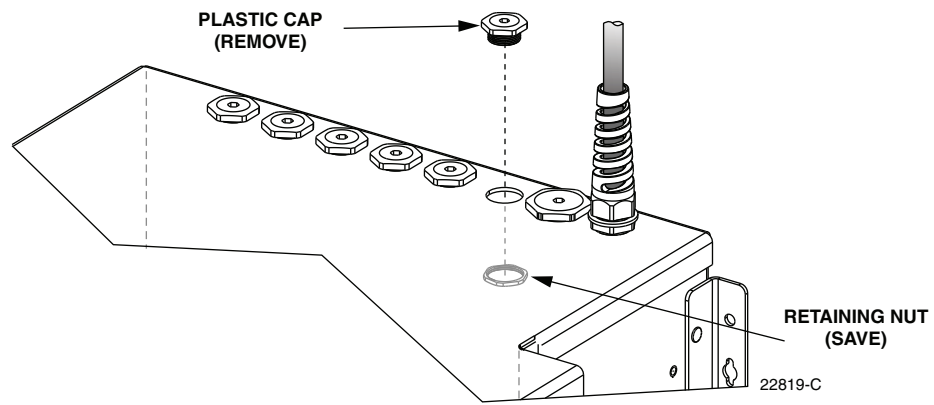

Figure 47. Plastic Cap Removal

4. Locate one of the distribution cable compression fittings that are shipped with the cabinet and loosely assemble the fitting as shown in [Figure 48](#).
- ▶ **Note:** Six distribution cable compression fittings are shipped with the cabinet. Additional compression fittings may be ordered separately if needed.
5. Install the O-ring on the threaded end of the compression fitting.

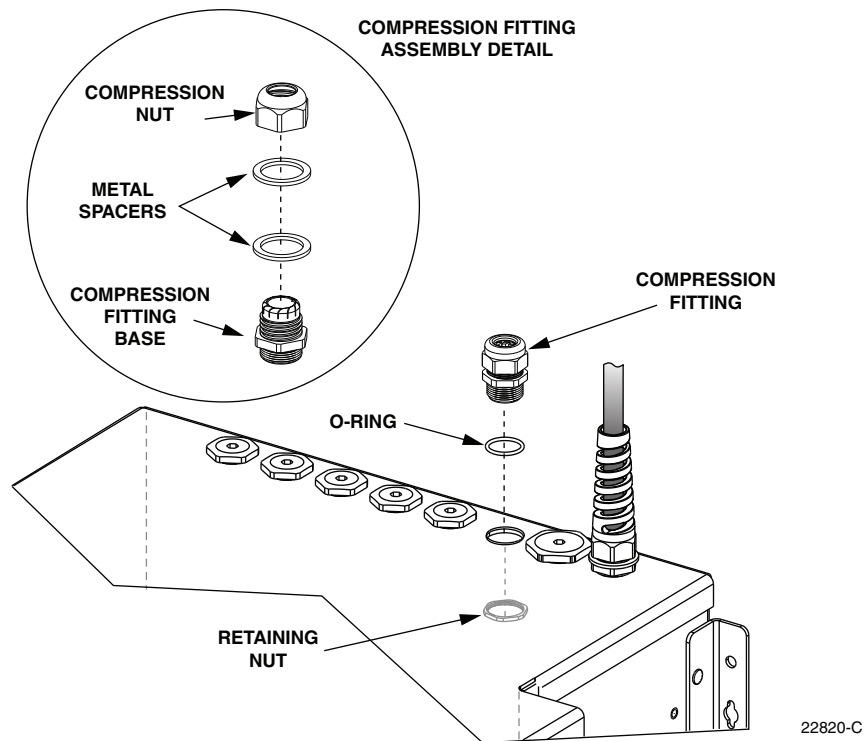

Figure 48. Distribution Cable Compression Fitting

6. Insert the threaded end of the compression fitting (with installed O-ring) into one of the designated distribution cable entry/exit holes and secure it to the cabinet with the retaining nut saved in step 3.
 7. Insert the connectorized ends of the six distribution cables through the installed compression fitting as shown in [Figure 49](#) and pull through 3 to 4 feet of cable slack into the cabinet.
- **Note:** Up to six 3 mm distribution cables may be routed into the cabinet through each entry/exit hole. All six cables should be installed at the same time.

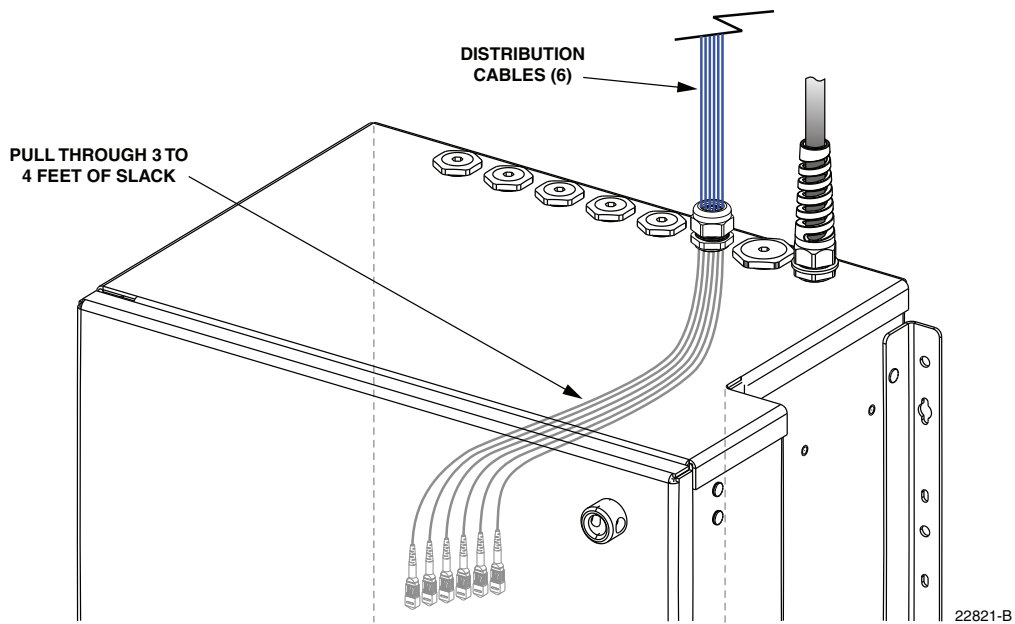

Figure 49. Inserting Distribution Cables into Compression Fitting

8. Install each distribution cable in the compression fitting grommet as shown in [Figure 50](#).

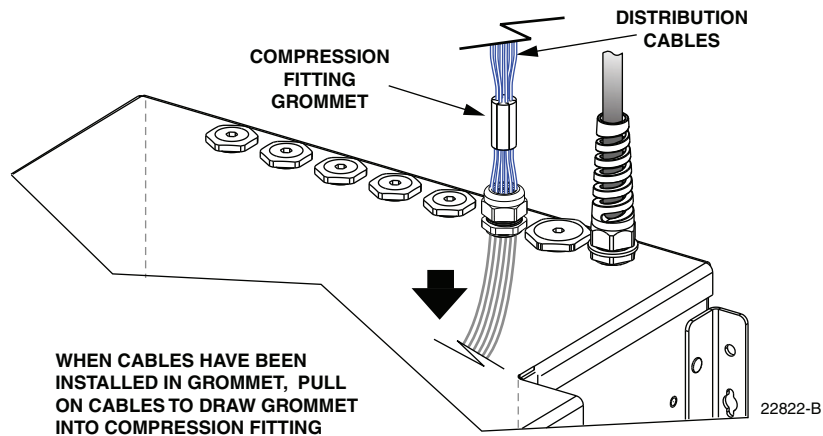

Figure 50. Install Distribution Cables in Grommet

9. Insert the grommet into the compression fitting, then pull on the distribution cables from the interior side of the cabinet until the top of the grommet is flush with the top of the compression fitting.
10. Locate the adapters on the bulkhead adapter panel that correspond to the distribution panel to which the distribution cables will be connected. The layout of the adapter panel is shown in [Figure 51](#).

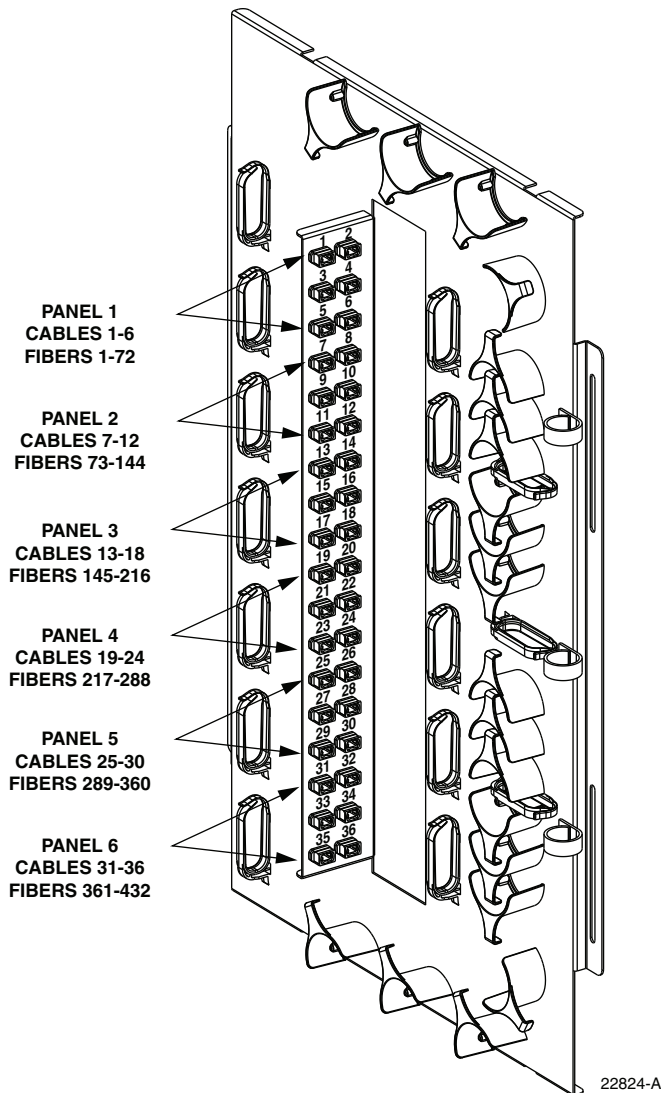

Figure 51. Layout of Bulkhead Adapter Panel

11. Route each distribution cable to the appropriate adapter on bulkhead adapter panel as shown in [Figure 52](#).
12. Remove the dust caps from the bulkhead adapters and the cable MTP® connectors as shown in [Figure 53](#).
13. Clean each MTP® connector as specified in the ADC Multifiber-Push On (MPO) Assembly Connector Cleaning Instructions (ADCP-96-150).

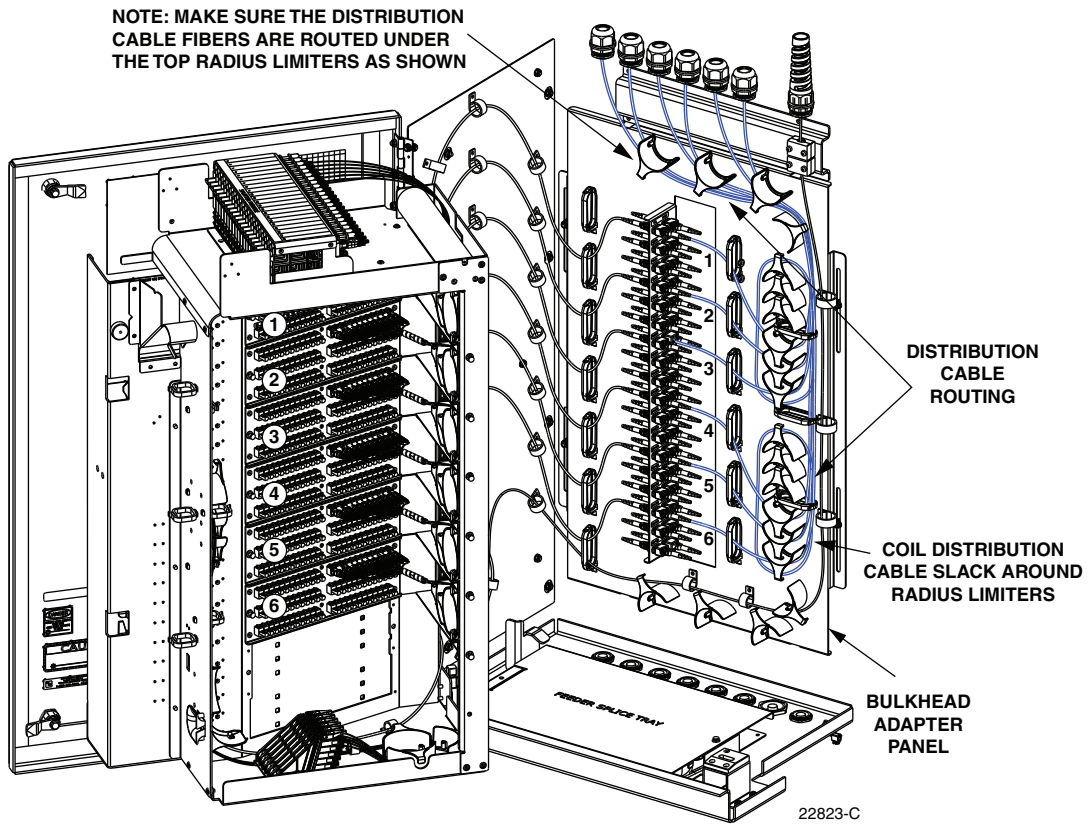

Figure 52. Routing Distribution Cables to Bulkhead Adapter Panel

14. Insert each MTP® connector into the appropriate bulkhead adapter. The white mark on the connector should align with the white mark on the adapter.

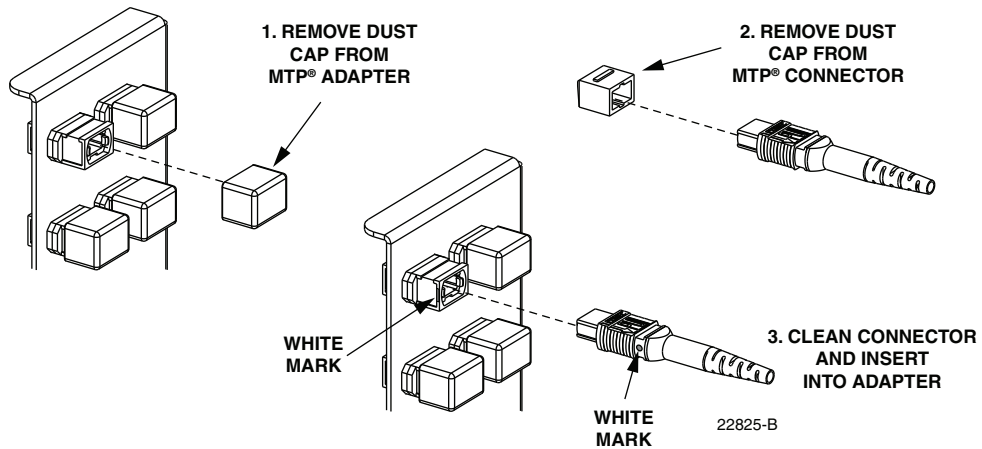

Figure 53. Connecting MTP® Connector to MTP Adapter

15. Take up all excess cable slack using the radius limiters provided. If necessary, slack may be removed/added by pulling the cable in/out of the cabinet through the grommet.
16. When all the distribution cables have been routed into the cabinet, connected, and the slack adjusted, tighten the compression nut to secure the distribution cables at the cable entry/exit hole.
 - ▶ **Note:** Two metal spacers are installed on the compression fitting to prevent the compression nut from being overtightened.
17. Repeat this procedure as needed for each distribution cable entry/exit hole.
18. Close the swingframe and the cabinet door when all the distribution cables have been installed.

9 DISTRIBUTION CABLE INSTALLATION AND ROUTING - BOTTOM ENTRY/EXIT

This section describes how to install **bottom** entry/exit distribution cables in the FDH 3000 indoor 432 cabinet with multi-fiber connectors. The distribution cables used with the cabinet must be rated for indoor use and designed for reduced bend radius applications. In addition, each distribution cable must be a 3 mm, stranded, 12-fiber cable terminated with a 12-fiber MTP® connector.

A compression-type fitting is provided for securing each distribution cable at the point where it enters the cabinet. Six 3 mm distribution cables may be routed into the cabinet through each entry/exit hole. Within the cabinet, the distribution cables are routed to the front side of the bulkhead adapter panel. Inserting the MTP® connectors into the appropriate bulkhead adapters connects the distribution cable fibers to the optical ports on the specified distribution panel.

The cabinet supports up to six distribution panels, each of which provides 72 optical ports. Each distribution panel is equipped with six 12-fiber subunits that are terminated with 12-fiber MTP® connectors. The fibers from the distribution panels are routed to the rear side of the bulkhead adapter panel where the MTP® connectors are inserted into specified bulkhead adapters.

Designation labels are provided on the cabinet doors for recording subscriber information for each distribution panel port. The labels indicate the connector number and cable number associated with each fiber port.

Use the following procedure to install bottom entry/exit distribution cables:

1. If the feeder cable has not been installed, complete steps 1 – 12 of [Section 7](#), Feeder Cable Installation and Splicing - Bottom Entry/Exit, before installing the distribution cables.
2. Locate the cable entry/exit holes (on the bottom of the cabinet) that are specified for distribution cable installation as shown in [Figure 54](#).

► **Note:** The distribution cables should be installed in numerical order starting with cables 1–6 for panel 1, cables 7–12 for panel 2, cables 13–18 for panel 3, cables 19–24 for panel 4, cables 25–30 for panel 5, and cables 31–36 for panel 6.

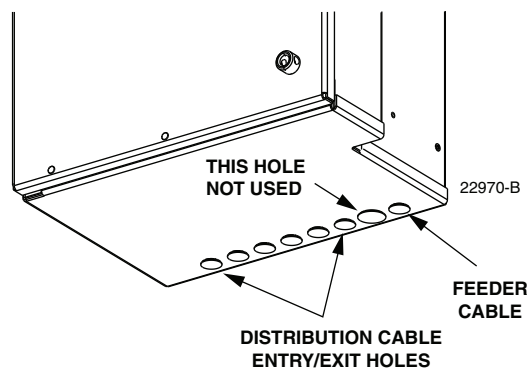

Figure 54. Distribution Cable Entry/Exit Holes

3. Open the cabinet door and swing frame to provide access to the interior of the cabinet.
4. Remove the plastic cap and retaining nut from the selected distribution cable entry/exit hole as shown in [Figure 55](#). Save the retaining nut for reuse.

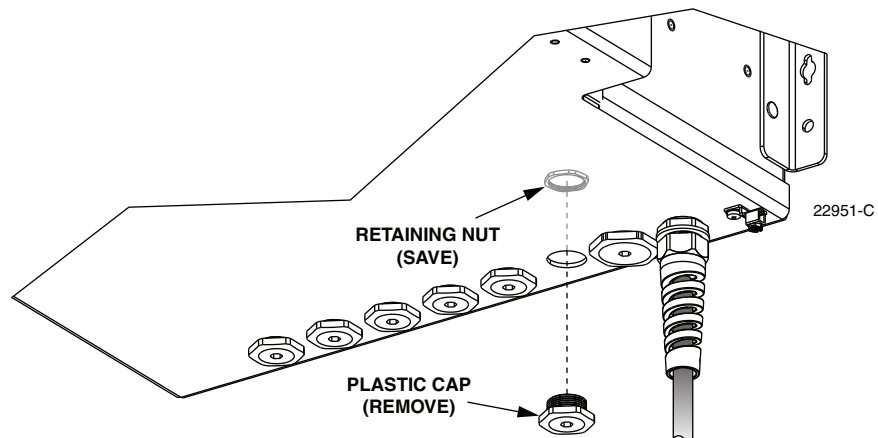

Figure 55. Plastic Cap Removal

5. Locate one of the distribution cable compression fittings that are shipped with the cabinet and loosely assemble the fitting as shown in [Figure 56](#).
- ▶ **Note:** Six distribution cable compression fittings are shipped with the cabinet. Additional compression fittings may be ordered separately if needed.
6. Install the O-ring on the threaded end of the compression fitting.
7. Insert the threaded end of the compression fitting (with installed O-ring) into one of the designated distribution cable entry/exit holes and secure it to the cabinet with the retaining nut saved in step 3.

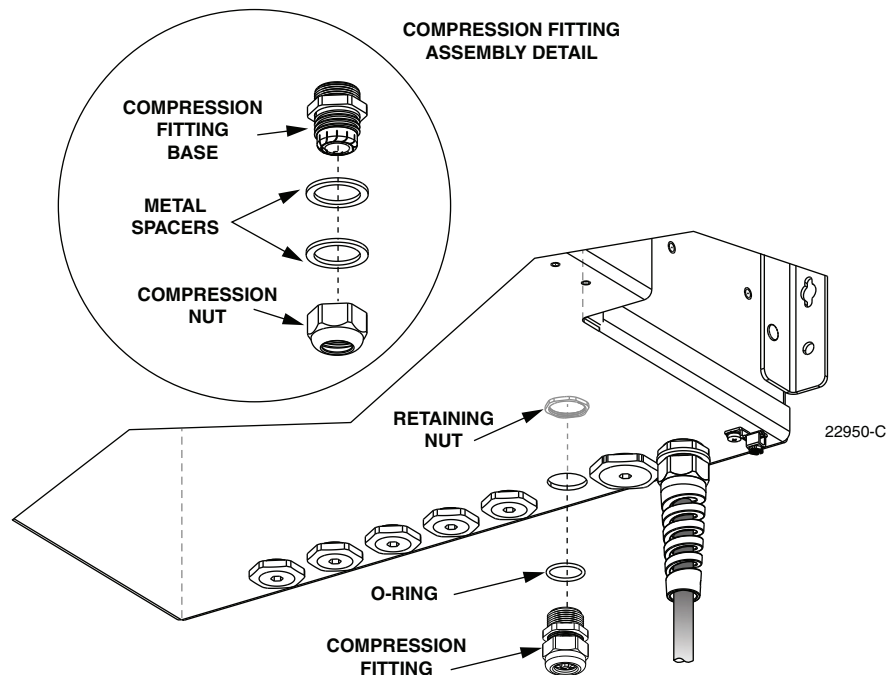

Figure 56. Distribution Cable Compression Fitting

8. Insert the connectorized ends of the six distribution cables through the installed compression fitting as shown in [Figure 57](#) and pull through 3 to 4 feet of cable slack into the cabinet.

▶ **Note:** Up to six 3 mm distribution cables may be routed into the cabinet through each entry/exit hole. All six cables should be installed at the same time.

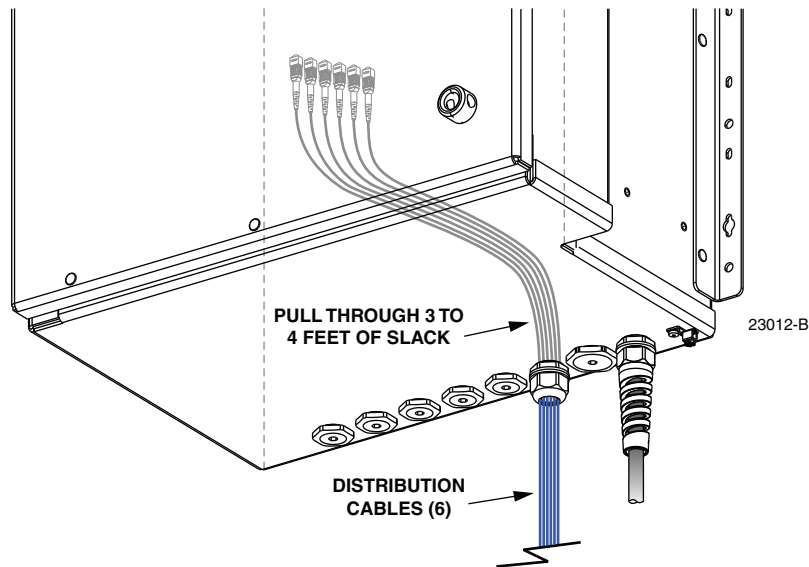

Figure 57. Inserting Distribution Cables into Compression Fitting

9. Install each distribution cable into the compression fitting grommet as shown in [Figure 58](#).

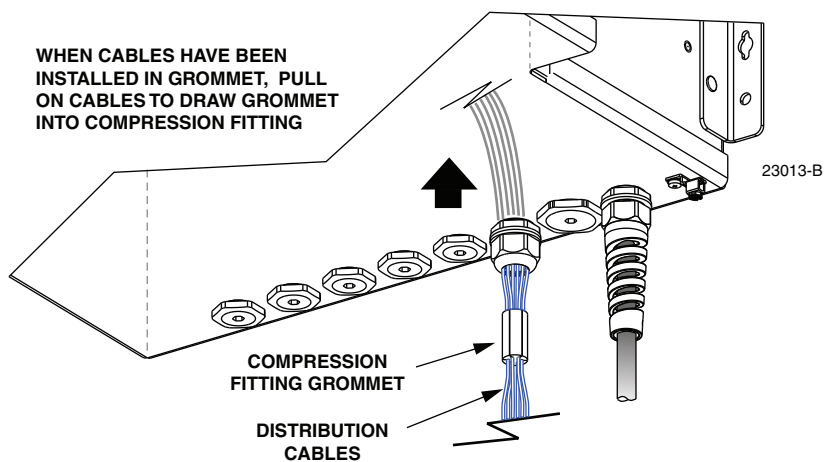

Figure 58. Install Distribution Cables in Grommet

10. Insert the grommet into the compression fitting, then pull on the distribution cables from the interior side of the cabinet until the top of the grommet is flush with the top of the compression fitting.

11. Locate the adapters on the bulkhead adapter panel that correspond to the distribution panel to which the distribution cables will be connected. The layout of the adapter panel is shown in [Figure 59](#).

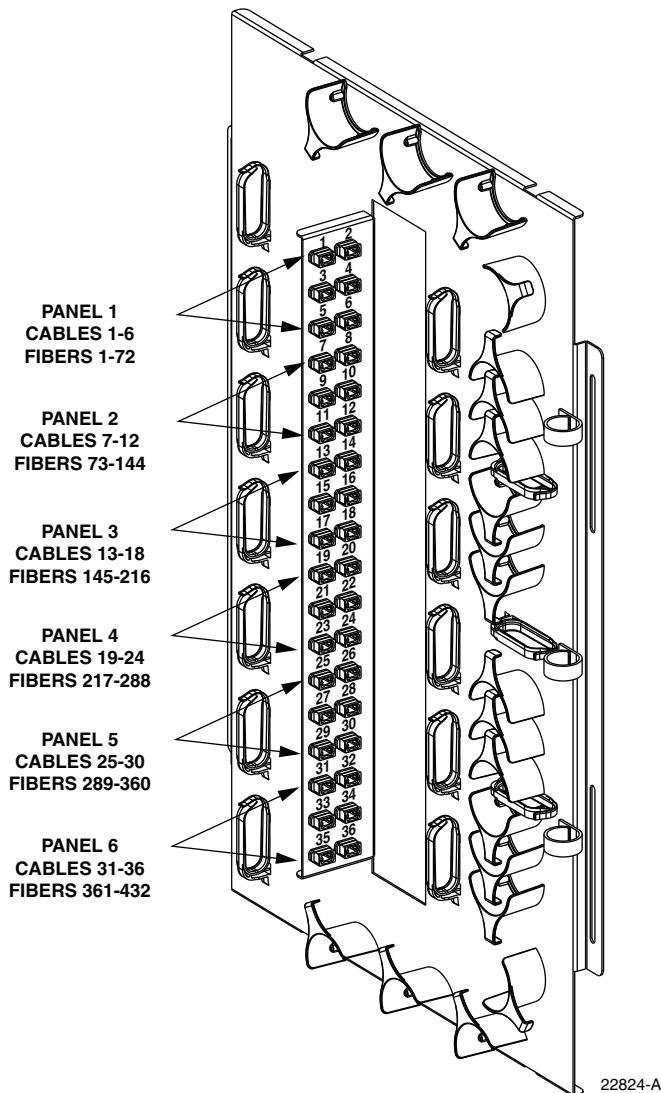

Figure 59. Layout of Bulkhead Adapter Panel

12. Route each distribution cable to the appropriate adapter on bulkhead adapter panel as shown in [Figure 60](#).
13. Remove the dust caps from the bulkhead adapters and the cable MTP® connectors as shown in [Figure 61](#).
14. Clean each MTP® connector as specified in the ADC Multifiber-Push On (MPO) Assembly Connector Cleaning Instructions (ADCP-96-150).

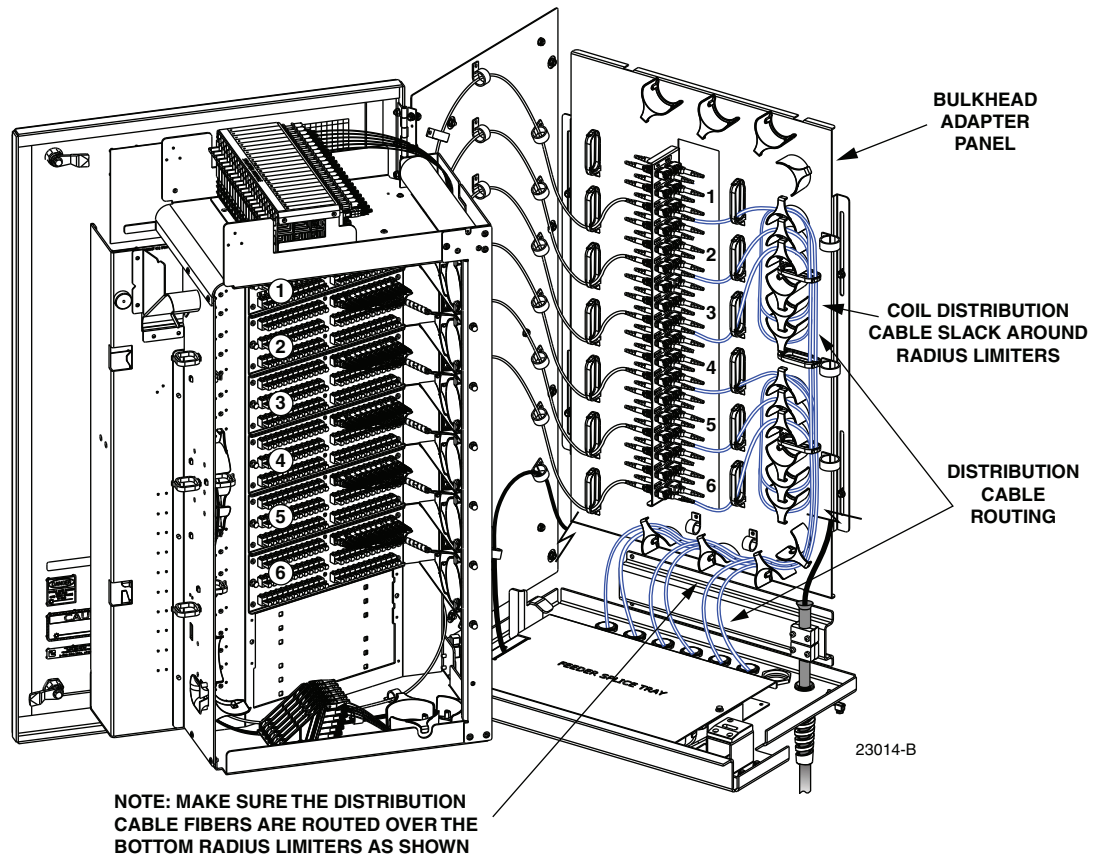

Figure 60. Routing Distribution Cables to Bulkhead Adapter Panel

15. Insert each MTP® connector into the appropriate bulkhead adapter. The white mark on the connector should align with the white mark on the adapter.

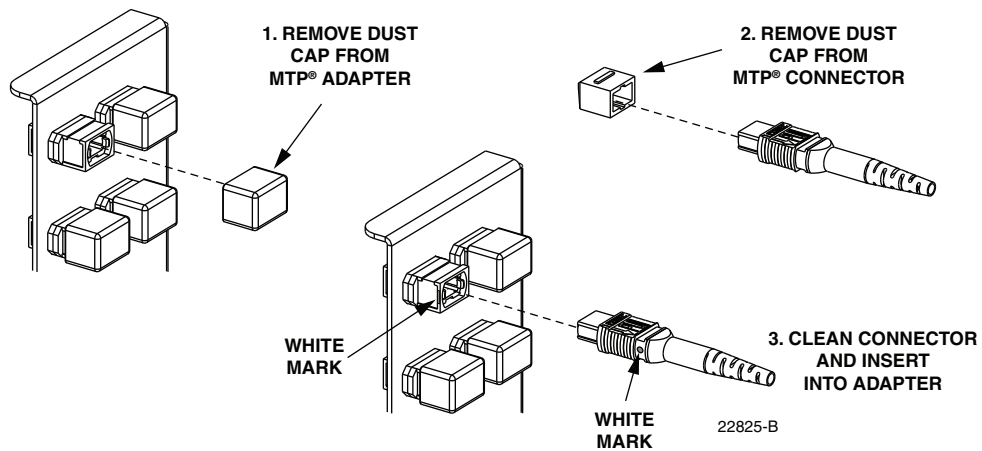

Figure 61. Connecting MTP Connector to MTP Adapter

16. Take up all excess cable slack using the radius limiters provided. If necessary, slack may be removed/added by pulling the cable in/out of the cabinet through the grommet.
17. When all the distribution cables have been routed into the cabinet, connected, and the slack adjusted, tighten the compression nut to secure the distribution cables at the cable entry/exit hole.
 - ▶ **Note:** Two metal spacers are installed on the compression fitting to prevent the compression nut from being overtightened.
18. Repeat this procedure as needed for each distribution cable entry/exit hole.
19. Close the swingframe and the cabinet door when all the distribution cables have been installed.

10 PLUG AND PLAY SPLITTER MODULE INSTALLATION

The FDH 3000 indoor 432 cabinet with multi-fiber connectors can accommodate up to twenty-two plug-and-play splitter modules. Splitter modules are equipped with either one or two input connectors and up to 64 output fibers. The splitter modules insert into slots in the splitter compartment. Inserting a splitter into the splitter compartment connects the splitter input connector(s) to the feeder cable connector(s). The splitter output fibers may be stored for later use or routed to the distribution panels for connection to the distribution ports.

Additional instructions for installing plug and play splitter modules are provided in the FDH 3000 Plug and Play Splitter Installation Guide (ADCP-96-087). Use only splitters equipped with reduced bend radius fibers.

Use the following procedure to install additional splitters in the cabinet:

1. Open the cabinet door and swing frame to provide access to the splitter compartment.
2. Locate the next available splitter mounting position as shown in [Figure 62](#).

► **Note:** Install splitters in the order shown, beginning on the left side of the splitter compartment and then working toward the right.

3. Remove the dust cap assembly from the selected splitter slot.

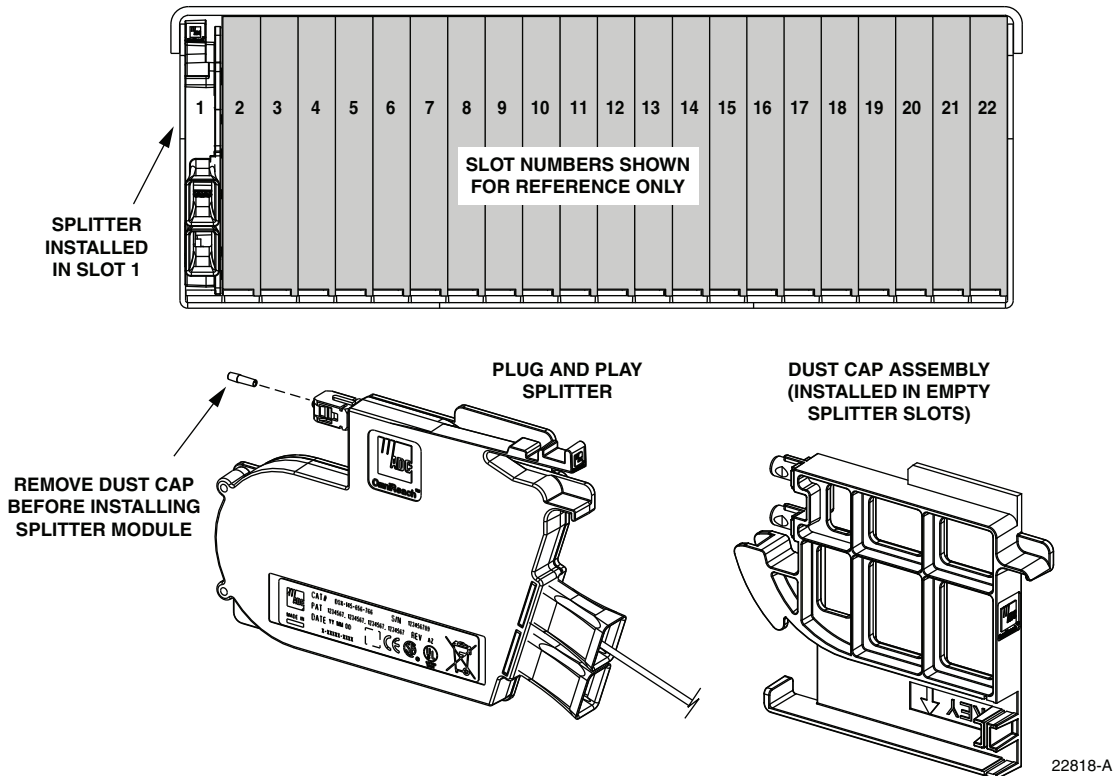

Figure 62. Splitter Module Installation

4. Remove the corresponding feeder cable connector(s) from the rear of the splitter compartment as shown in [Figure 63](#).



Warning: *Infrared radiation is invisible and can seriously damage the retina of the eye. Do not look into the ends of any optical fiber. Do not look directly into the optical adapters or connectors. Exposure to invisible laser radiation may result. An optical power meter should be used to verify active fibers. A protective cap or hood **MUST** be immediately placed over any radiating adapter or optical connector to avoid the potential of dangerous amounts of radiation exposure. This practice also prevents dirt particles from entering the adapter or connector.*

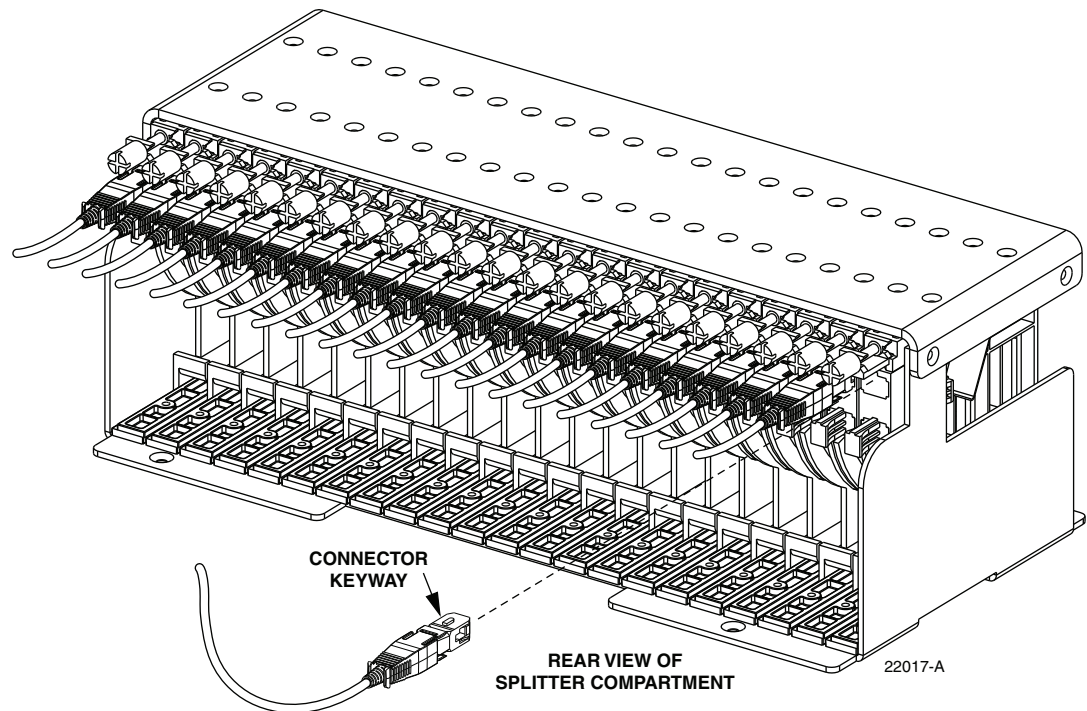

Figure 63. Feeder Cable Connector

5. Clean the feeder cable connector(s) as specified in the Optical Fiber Systems Cleaning and Mating Instructions (ADCP-90-159).
6. Reinstall the feeder cable connector(s) at the rear of the splitter compartment.
7. Remove the dust cap from the splitter connector (see [Figure 62](#)).
8. Insert the splitter into the mounting slot as shown in [Figure 64](#).
9. Route the splitter output fibers to the connector storage panel or to the designated subscriber port. Refer to [Section 12](#) for the routing procedure.
10. Close the swingframe and cabinet door when the splitters have been installed.

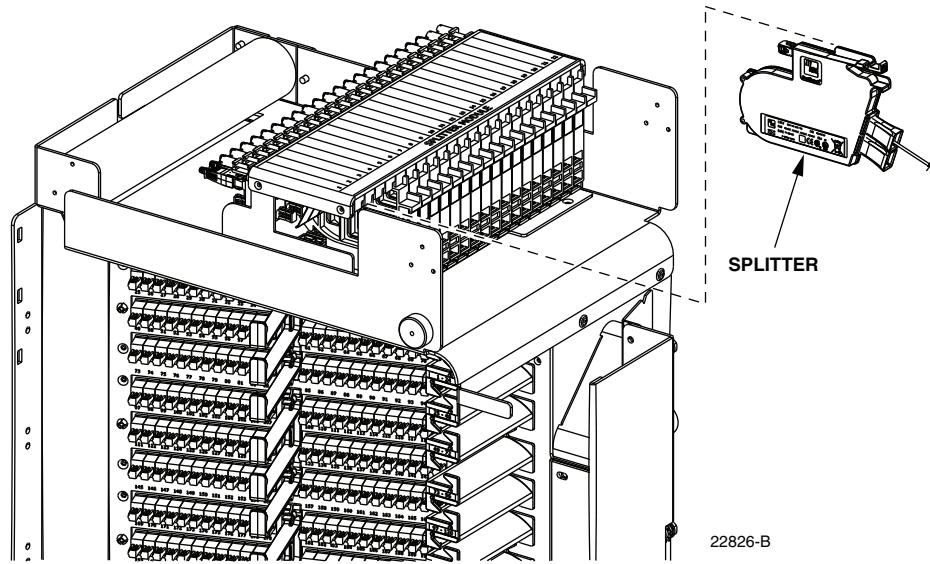

Figure 64. Splitter Installation

11 DISTRIBUTION PANEL INSTALLATION

The FDH 3000 indoor 432 cabinet with multi-fiber connectors can be ordered with up to six 72-position distribution panels pre-installed in the cabinet. If the cabinet has unused distribution panel mounting slots, then additional panels may be installed when needed. Use the following procedure to install a distribution panel in an unused mounting slot:

1. Open the cabinet door and the swingframe to provide access to the interior of the cabinet.
2. Remove the filler plate from the unused mounting slot.
3. Place the distribution panel in position for mounting on the **rear** side of the swingframe as shown in [Figure 65](#).
4. Use the plastic push pins provided to secure the distribution panel to the rear side of the swingframe.

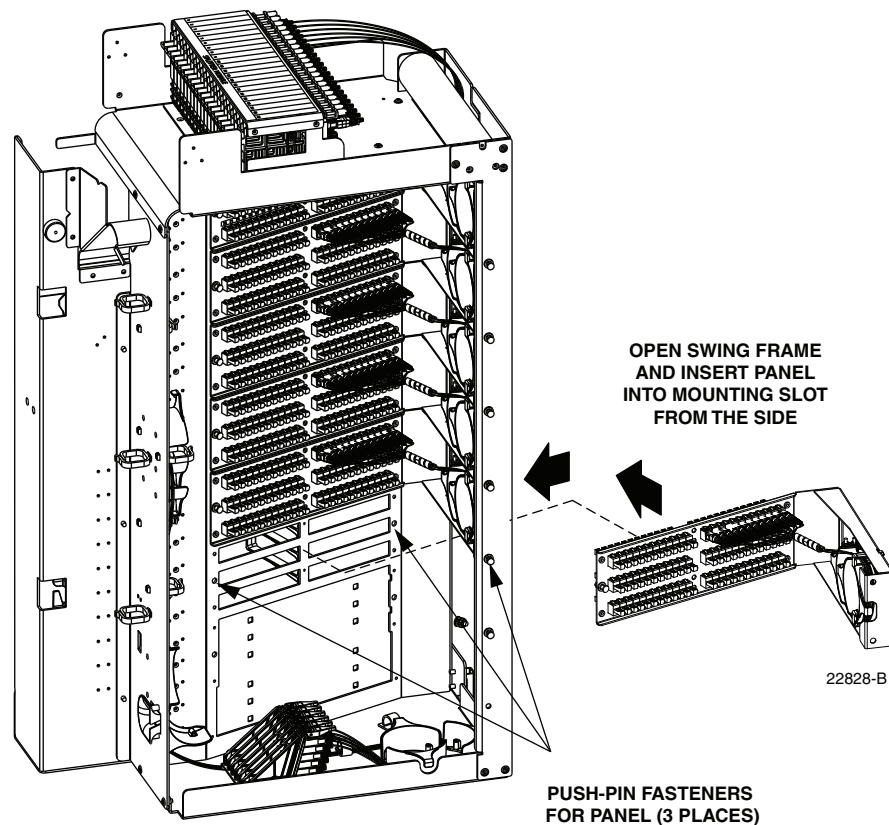

Figure 65. Placing Distribution Panel In Position For Mounting

5. Working from the front, use the four screws provided with the panel to secure the front of the distribution panel to the swing frame as shown in [Figure 66](#).

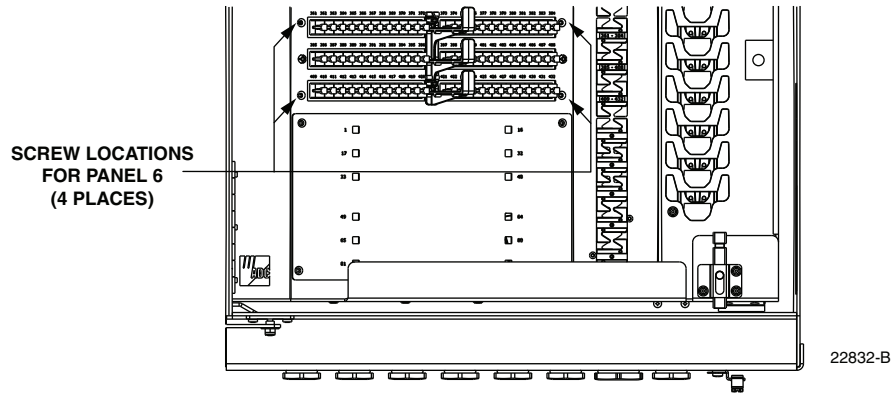

Figure 66. Securing Distribution Panel to Swing Frame

6. Locate the adapters on the bulkhead adapter panel that correspond to the distribution panel being installed. The layout of the adapter panel is shown in [Figure 68](#).

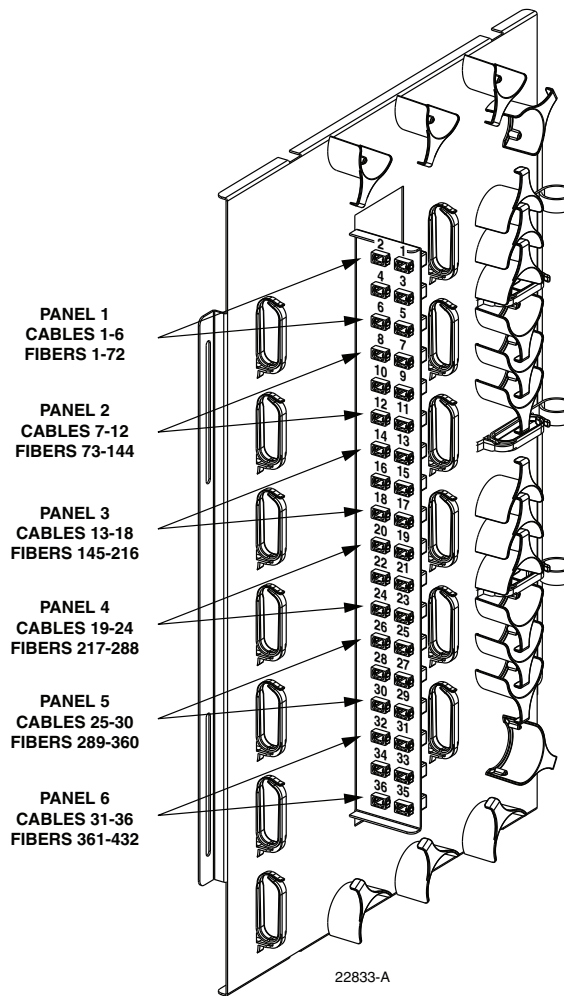

Figure 67. Layout of Bulkhead Adapter Panel

7. Route the distribution panel subunit fibers to the appropriate adapter on bulkhead adapter panel as shown in Figure 68.

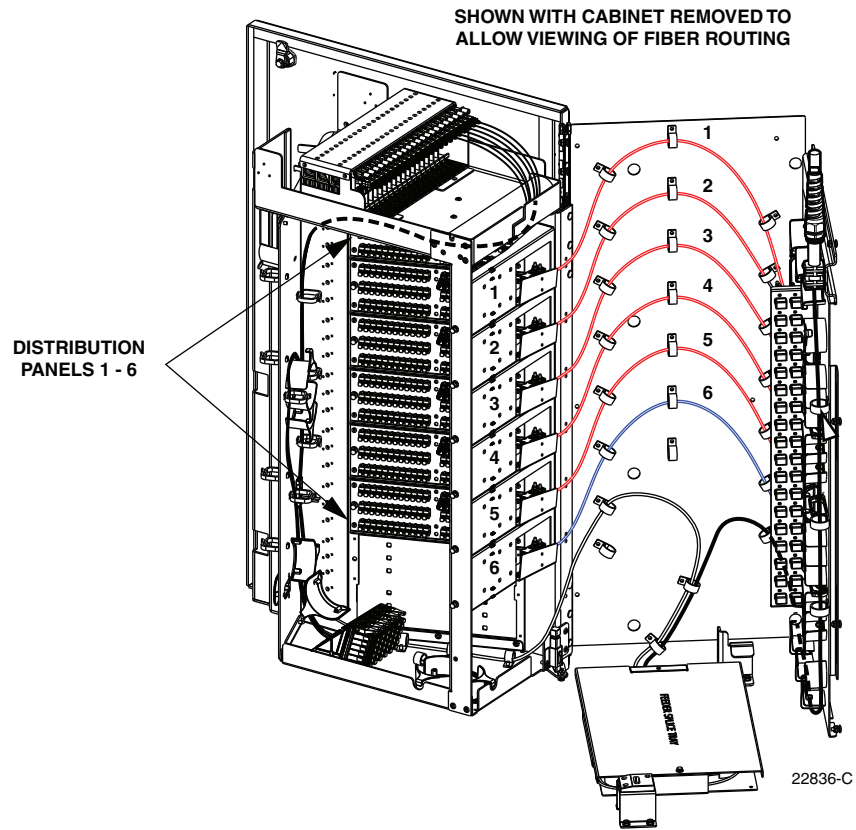

Figure 68. Distribution Cable Fiber Routing

8. Remove the dust caps from the bulkhead adapters and the subunit MTP® connectors as shown in Figure 69.

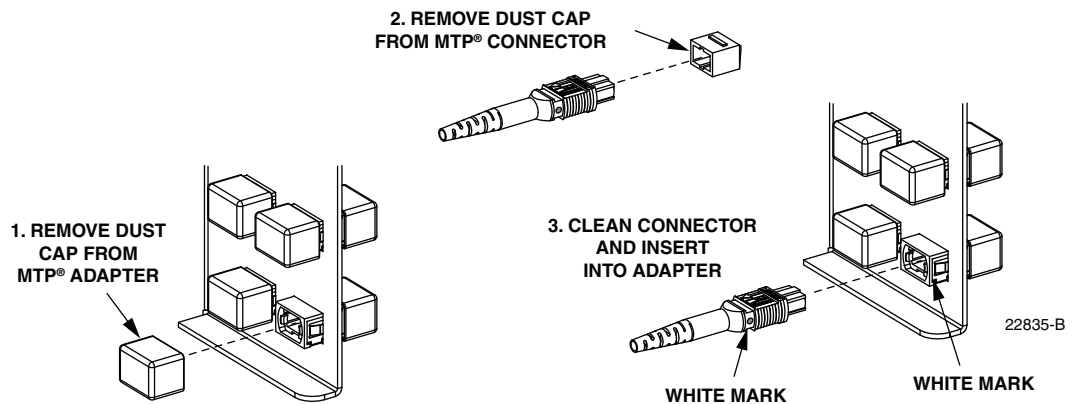

Figure 69. Connecting MTP® Connector to MTP® Adapter

9. Clean each MTP® connector as specified in the ADC Multifiber-Push On (MPO) Assembly Connector Cleaning Instructions (ADCP-96-150).
10. Insert each MTP® connector into the appropriate bulkhead adapter. The white mark on the connector should align with the white mark on the adapter.
11. Close the swingframe and the cabinet door when the installation of the distribution panel is finished.

12 ROUTING AND CONNECTING THE SPLITTER OUTPUT FIBERS

The splitter modules are mounted at the top of the cabinet's swingframe. When a splitter module is initially installed, the output fibers are routed to the storage panel located at the bottom of the cabinet. At the storage panel, the output fibers are temporarily "parked" until they are needed. Service to a subscriber is enabled by removing an unused output fiber from the storage panel, routing it to the appropriate distribution panel, and then connecting it to the subscriber port.

12.1 Storing The Splitter Output Fibers

Use the following procedure to store the splitter output fibers.

1. Following installation of a splitter module, locate an open connector pack slot in the storage panel at the bottom of the cabinet.
2. Insert the connector pack into the unused slot in the storage panel. Refer to the FDH 3000 Plug and Play Splitter Installation Guide (ADCP-96-087) provided with splitter modules for additional information on installing connector packs in the storage panel.
3. Use the radius limiters on the right side of the cabinet to store any excess fiber slack. Refer to [Figure 70](#) for the routing guidelines.

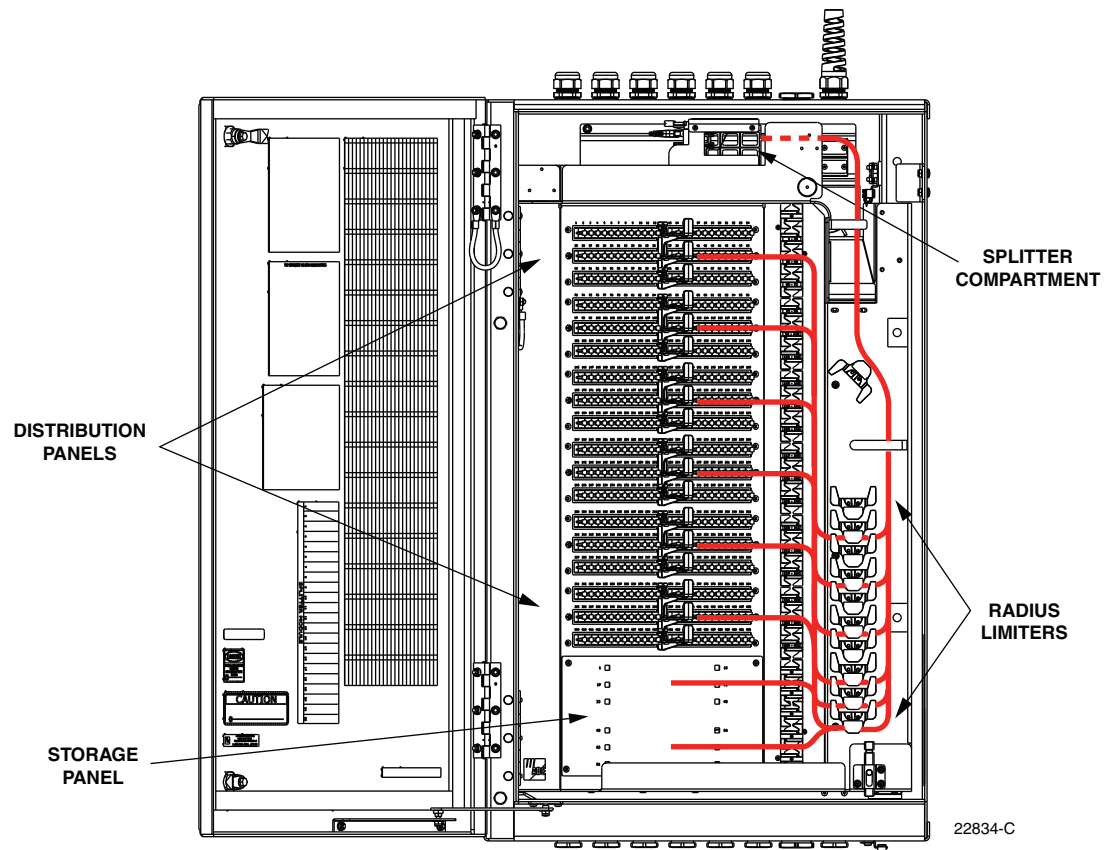

Figure 70. Routing Splitter Output Fibers

12.2 Enabling Service To a Subscriber

Use the following procedure to enable service to a subscriber:

1. Check the designation labels on the cabinet doors to determine the distribution panel and port number that corresponds to the address of the subscriber.
2. Locate the subscriber port on the specified distribution panel and remove both the adapter dust cap and the connector ferrule dust cap.
3. Select and remove an unused splitter output fiber from the storage panel and carefully work it free of any other fibers.



Warning: *Infrared radiation is invisible and can seriously damage the retina of the eye. Do not look into the ends of any optical fiber. Do not look directly into the optical adapters or connectors. Exposure to invisible laser radiation may result. An optical power meter should be used to verify active fibers. A protective cap or hood MUST be immediately placed over any radiating adapter or optical connector to avoid the potential of dangerous amounts of radiation exposure. This practice also prevents dirt particles from entering the adapter or connector.*

4. Remove the ferrule dust cap from the connector and then clean the connector as specified in the Optical Fiber Systems Cleaning and Mating Instructions (ADCP-90-159).
5. Connect the splitter output fiber connector to the subscriber port.
6. Use the radius limiters on the right side of the cabinet to store any excess fiber slack. Refer to [Figure 70](#) for the routing guidelines



Caution: *Always allow sufficient fiber length to permit routing without severe bends. Non reduced bend radius fibers may be permanently damaged if bent or curved to a radius of less than 1.5 inches (3.81 cm).*

13 PASS-THROUGH ROUTING PROCEDURE

Pass-through routing is used when it is necessary for a feeder cable optical signal to be routed directly to a distribution port. This involves connecting a patch cord between the terminated feeder cable connector and the appropriate distribution port. Because feeder cable fibers can be terminated at either the sliding adapter pack or the splitter compartment, two pass-through routing procedures are provided.

13.1 Sliding Adapter Pack Pass-Through Routing Procedure

Use the following procedure to route a jumper patch cord between the feeder cable sliding adapter pack and one of the distribution panels.

1. Open the swing frame and locate the appropriate feeder cable connector on the sliding adapter pack.
2. Pull upward on the small tab on top of the adapter pack and lift the adapter pack to the position shown in [Figure 71](#)

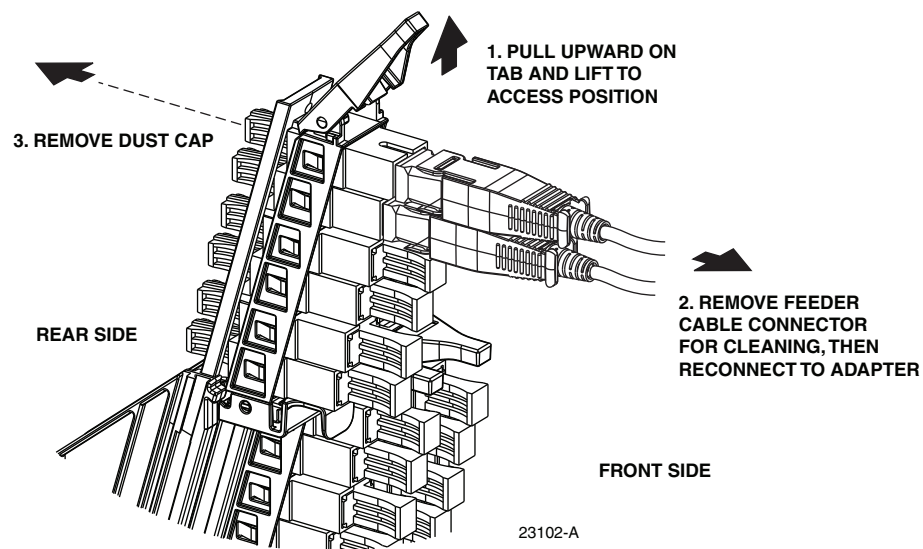

Figure 71. Adapter Pack Raised to Access Position



Warning: *Infrared radiation is invisible and can seriously damage the retina of the eye. Do not look into the ends of any optical fiber. Do not look directly into the optical adapters or connectors. Exposure to invisible laser radiation may result. An optical power meter should be used to verify active fibers. A protective cap or hood **MUST** be immediately placed over any radiating adapter or optical connector to avoid the potential of dangerous amounts of radiation exposure. This practice also prevents dirt particles from entering the adapter or connector.*

3. Remove the feeder cable connector from the rear side of the bulkhead adapter and clean the connector as specified in the Optical Fiber Connector Wet and Dry Cleaning Instructions (ADCP-90-159) or by locally approved procedures.

4. Reconnect the feeder cable connector to the bulkhead adapter.
 5. Remove the dust cap from the front side of the bulkhead adapter.
 6. Obtain the optical patch cord (accessory) recommended for the pass-through connection.
- ▶ **Note:** Use catalog# FPCFW-APSC-P-2.1M for APC/SC connectors.
 Use catalog# FPCFW-SPSC-P-2.1M for UPC/SC connectors.
7. Remove the ferrule dust cap from one of the patch cord connectors and then clean the connector as specified in the Optical Fiber Connector Wet and Dry Cleaning Instructions (ADCP-90-159) or by locally approved procedures.
 8. Insert the patch cord connector into the bulkhead adapter in the sliding adapter pack.
 9. Slide the adapter pack down into the closed position.
 10. Route the pass-through patch cord to the front side of the swing frame as shown in [Figure 72](#).



Caution: Always allow sufficient fiber length to permit routing without severe bends. Non reduced bend radius fibers may be permanently damaged if bent or curved to a radius of less than 1.5 inches (3.81 cm).

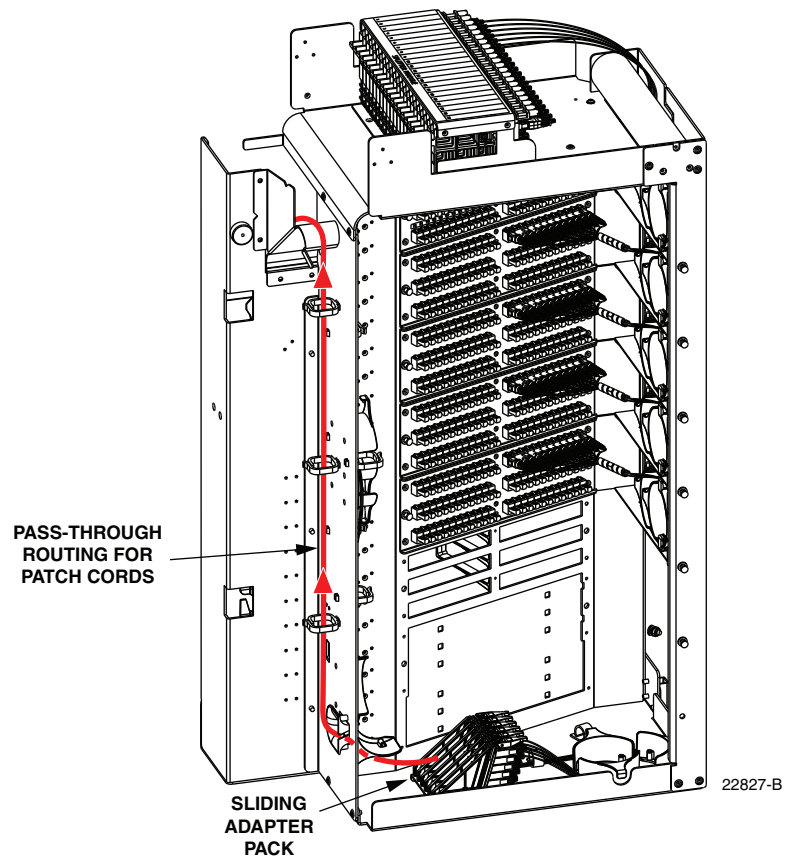

Figure 72. Routing Pass-Through Patch Cord From Sliding Adapter Pack

11. Locate the distribution panel and the optical port to which the pass-through patch cord is to be routed.
12. Refer to the procedures in [Section 12.2](#) to route the pass-through patch cord to the distribution panel and to connect the patch cord connector to the appropriate optical port. Maintain a 1.5-inch minimum bend radius for all non reduced bend radius fiber.
13. Close swing frame when pass-through routing procedure is complete.

13.2 Splitter Compartment Pass-Through Routing Procedure

Use the following procedure to route a jumper patch cord between the splitter compartment and one of the distribution cable distribution panels.

1. Open the swing frame and locate an open splitter mounting position.
2. Remove the dust cap assembly from the selected splitter slot.
3. Remove the feeder cable connector(s) from the rear of the splitter compartment (see [Figure 63](#)).



Warning: *Infrared radiation is invisible and can seriously damage the retina of the eye. Do not look into the ends of any optical fiber. Do not look directly into the optical adapters or connectors. Exposure to invisible laser radiation may result. An optical power meter should be used to verify active fibers. A protective cap or hood MUST be immediately placed over any radiating adapter or optical connector to avoid the potential of dangerous amounts of radiation exposure. This practice also prevents dirt particles from entering the adapter or connector.*

4. Clean the feeder cable connector(s) as specified in the Optical Fiber Systems Cleaning and Mating Instructions (ADCP-90-159).
5. Reinstall the feeder cable connector(s) at the rear of the splitter compartment.
6. Obtain the optical patch cord (accessory) recommended for the pass-through connection.
7. Remove the ferrule dust cap from one of the patch cord connectors and then clean the connector as specified in the Optical Fiber Connector Wet and Dry Cleaning Instructions (ADCP-90-159) or by locally approved procedures.
8. Install the patch cord connector in the dust cap assembly as shown in [Figure 73](#).
- **Note:** Two patch cord connectors may be installed in the dust cap assembly if required.
9. Connect the patch cord connector(s) to the feeder cable connector(s) by inserting the dust cap assembly into the splitter slot as shown in [Figure 74](#).
10. Locate the distribution panel and the optical port to which the pass-through patch cord is to be routed.
11. Refer to the procedures in [Section 12.2](#) to route the pass-through patch cord to the distribution panel and to connect the patch cord connector to the appropriate optical port.
12. Close swing frame when pass-through routing procedure is complete.

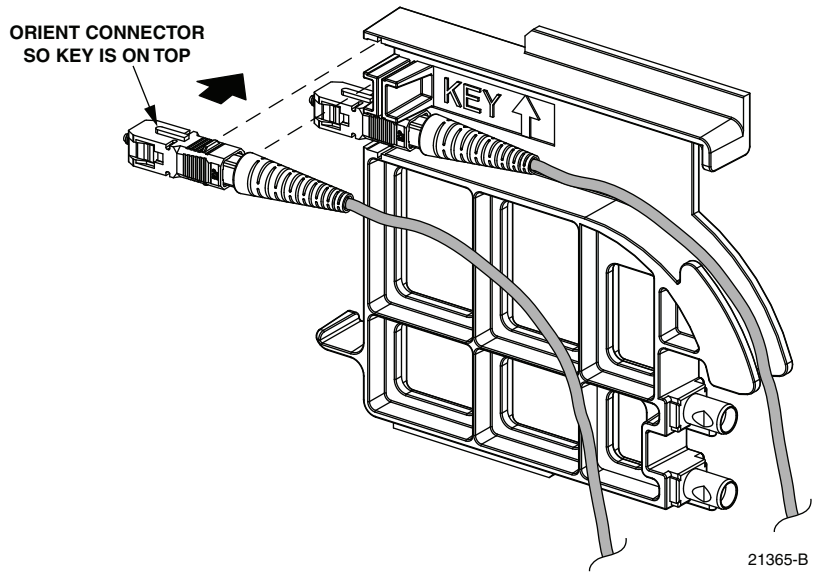

Figure 73. Installing Patch Cord Connector in Dust Cap Assembly

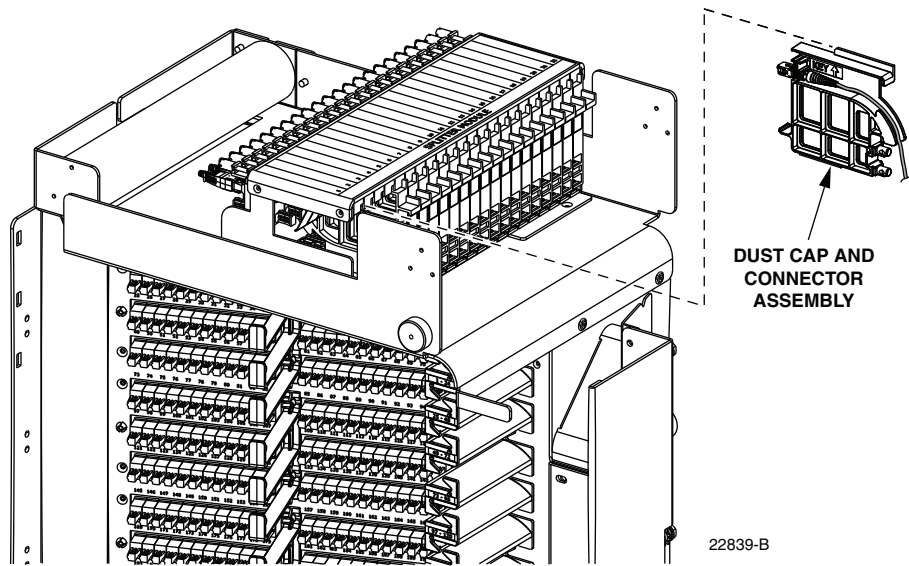

Figure 74. Inserting Dust Cap Assembly Into Splitter Compartment

14 FEEDER CABLE FIBER RE-ROUTING PROCEDURE

The feeder cable fibers may be terminated by the factory at either the sliding adapter pack or at the splitter compartment. Feeder cable fibers that were terminated at the sliding adapter pack may sometime require re-termination at the splitter compartment. Use the following procedure to re-route a feeder cable fiber from the sliding adapter pack to the splitter compartment.

1. Open the swing frame and locate the sliding adapter pack.
2. Locate the feeder cable fiber that requires re-termination at the splitter compartment.
3. Pull upward on the small tab on top of the adapter pack and lift the adapter pack to the position shown in [Figure 75](#).

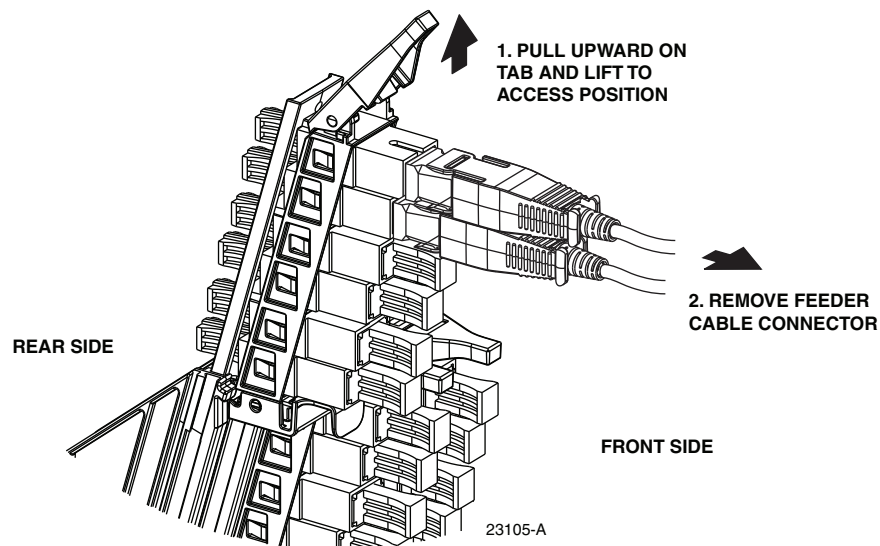

Figure 75. Adapter Pack Raised to Access Position

4. Disconnect the feeder cable connector from the rear side of the sliding adapter pack and place a dust cap over the connector ferrule. This will protect the connector since it will be difficult to prevent the connector from getting dirty during the re-routing procedure.



Warning: *Infrared radiation is invisible and can seriously damage the retina of the eye. Do not look into the ends of any optical fiber. Do not look directly into the optical adapters or connectors. Exposure to invisible laser radiation may result. An optical power meter should be used to verify active fibers. A protective cap or hood MUST be immediately placed over any radiating adapter or optical connector to avoid the potential of dangerous amounts of radiation exposure. This practice also prevents dirt particles from entering the adapter or connector.*

5. Place a dust cap over the exposed bulkhead adapter and then slide the adapter pack down to the closed position.
6. Carefully unwind the feeder fiber from the radius limiters located on the bottom and on the left side of the swing frame. [Figure 76](#) shows the section of the fiber that will need to be released for re-routing. When necessary, backfeed the fiber to free the connector from the remaining fibers.

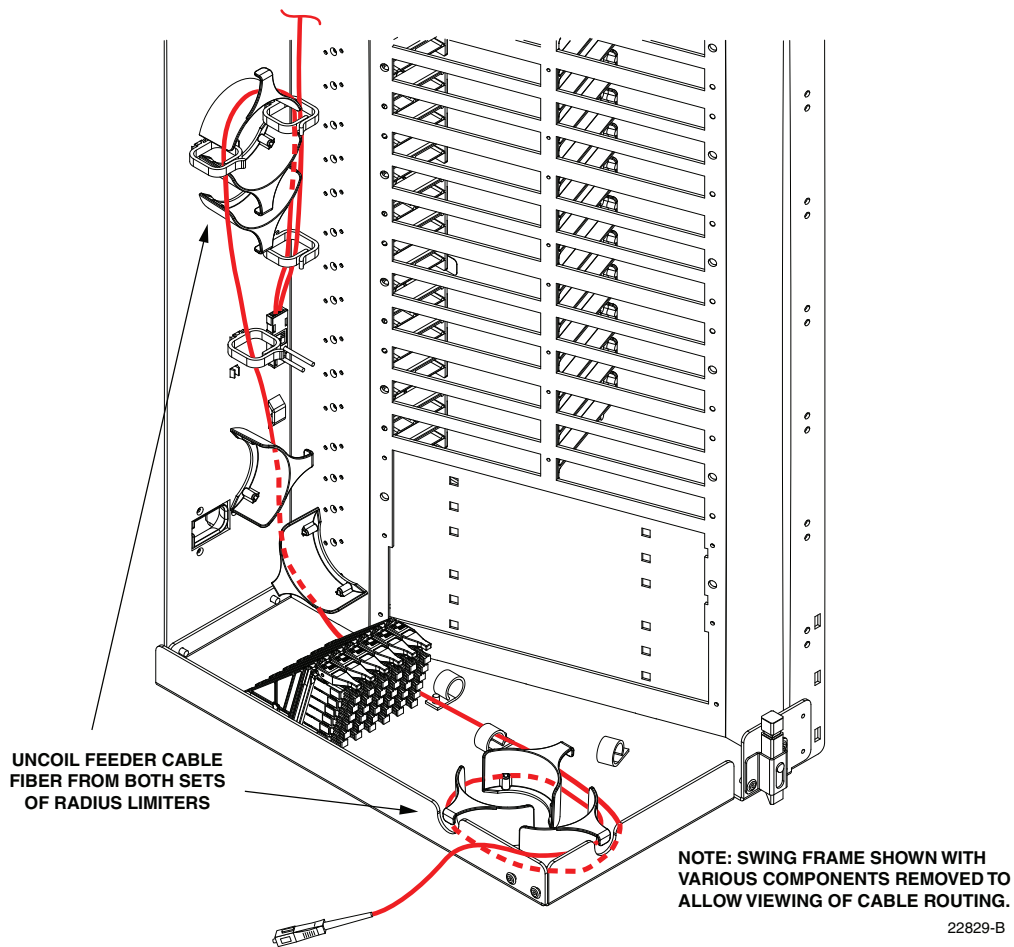

Figure 76. Uncoiling the Feeder Cable Fiber

7. When the feeder cable connector and fiber are free, pass the connector through the opening located behind the splitter compartment as shown in [Figure 77](#).
 8. Remove the ferrule dust cap from the feeder cable connector and then clean the connector as specified in the Optical Fiber Connector Wet and Dry Cleaning Instructions (ADCP-90-159) or by locally approved procedures.
 9. Insert the feeder fiber connector into the appropriate bulkhead adapter (remove dust cap from adapter) at the rear of the splitter compartment as shown in [Figure 78](#).
- **Note:** The splitter slot should not be left empty after the feeder fiber is connected to the bulkhead adapter at the rear side of the splitter compartment. Either a dust cap assembly or a splitter should be installed in the mounting slot.
10. Route the feeder fiber over the three supports located at the top of the swing frame.
 11. Store the excess slack on the radius limiters located on the left side of the swing frame.
 12. Close swingframe when feeder re-routing procedure is completed.

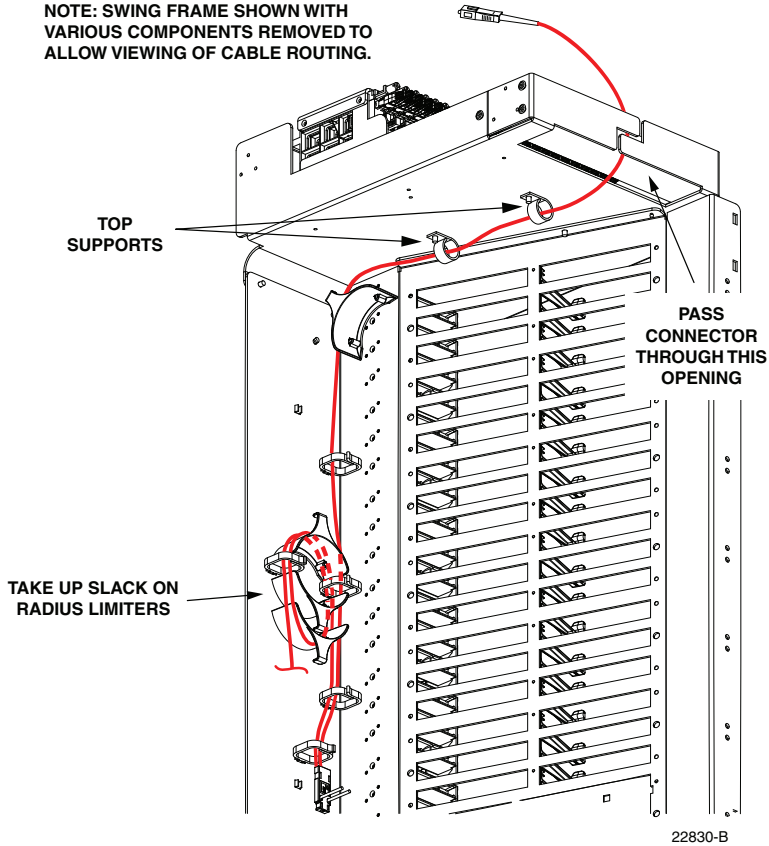

Figure 77. Re-Routing the Feeder Cable Fiber

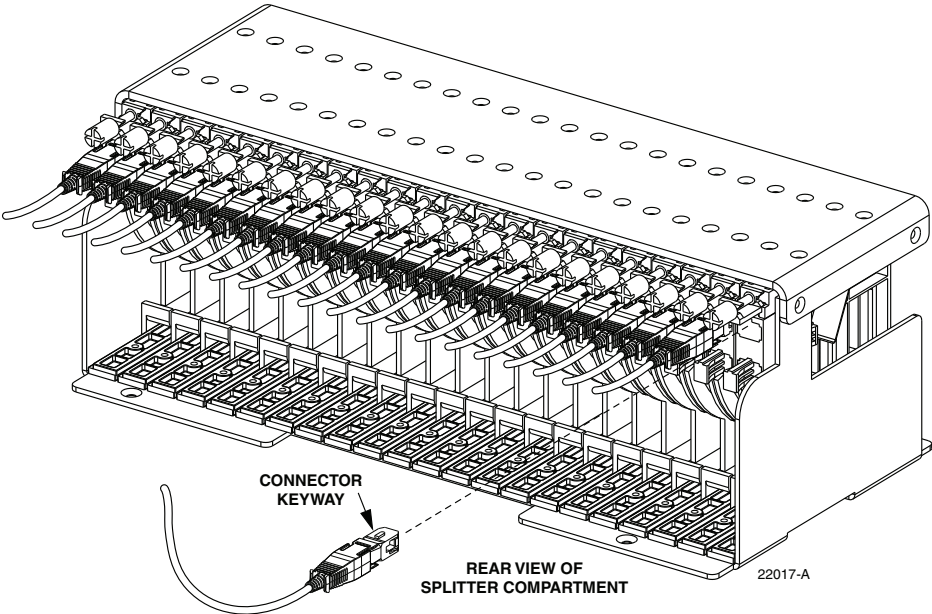

Figure 78. Feeder Cable Connector

15 MAINTENANCE AND REPAIR PROCEDURES

The FDH 3000 indoor 432 cabinet with multi-fiber connectors requires no regular maintenance to insure continuous and satisfactory operation. Maintenance is limited to repairing or replacing any cabinet components that may be damaged or broken in the course of normal operation. The following sections provide procedures for repairing or replacing common cabinet components.

15.1 Painting

Brush-in-cap type bottles of paint (order catalog# ACE-ACC-PTALMD) are available for touching-up nicks and scratches in the factory coat of paint. Lightly sand the area to be painted and then clean it thoroughly to remove any dirt, dust, or foreign matter. Shake the paint bottle until thoroughly mixed and then apply a light coat of paint to the damaged area using the small brush attached to the cap. Wait until the paint is dry and then apply a second coat if necessary. When finished painting, replace the paint bottle cap and tighten securely.

15.2 Distribution Panel Adapter Replacement

Replacement adapters are available for the distribution panels. Use the following procedure to remove and replace a damaged adapter:

1. Disconnect the splitter connector from the front side of the broken adapter as shown in [Figure 79](#) and install a dust cap on the connector.



Warning: *Infrared radiation is invisible and can seriously damage the retina of the eye. Do not look into the ends of any optical fiber. Do not look directly into the optical adapters or connectors. Exposure to invisible laser radiation may result. An optical power meter should be used to verify active fibers. A protective cap or hood MUST be immediately placed over any radiating adapter or optical connector to avoid the potential of dangerous amounts of radiation exposure. This practice also prevents dirt particles from entering the adapter or connector.*

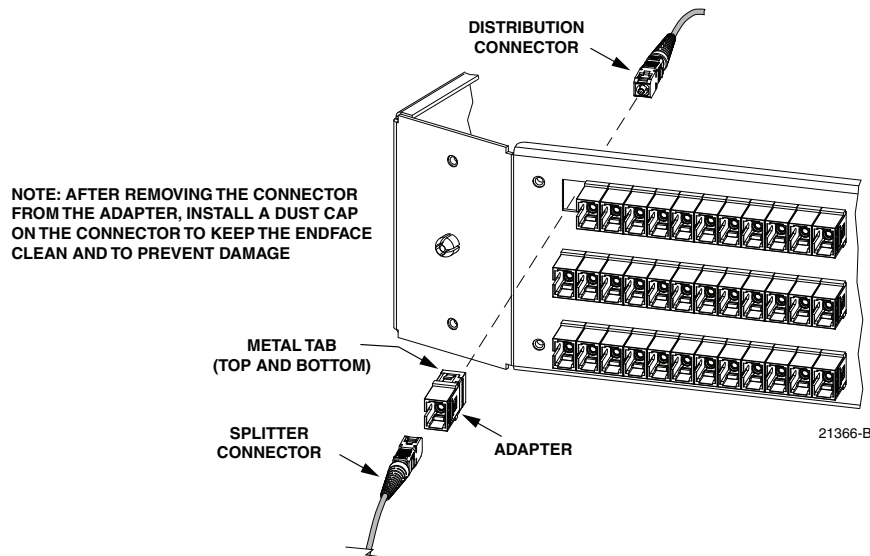

Figure 79. Adapter Removal and Replacement - Typical Distribution Panel

2. Unlatch and fully open the cabinet swing frame to provide access to the rear side of the distribution panel.
3. Disconnect the distribution connector from the rear side of the broken adapter and install a dust cap on the connector.



Caution: Use extreme care when removing a connector or an adapter from the distribution panel to avoid macro bending the adjacent fibers.

4. Working from the rear side of the distribution panel, use a large tweezers or two small screwdrivers (blade type) to depress the two metal tabs that retain the adapter in the panel. With both tabs depressed, push forward on the adapter until it pops out of the panel.
 5. Discard the damaged adapter.
 6. Install the replacement adapter by inserting it into the distribution panel from the front and then pushing it toward the back until it snaps into place.
- **Note:** Make sure the keyway in the replacement adapter is facing in the same direction as the keyways in the rest of the adapters installed in the distribution panel.
7. Clean the distribution and splitter fiber connectors as specified in the Optical Fiber Systems Cleaning and Mating Instructions (ADCP-90-159).
 8. Connect the distribution connector to the rear side of the replacement adapter.
 9. Close the cabinet swing frame.
 10. Connect the splitter connector to the front side of the replacement adapter.

15.3 Splitter Compartment Adapter Replacement

Replacement adapter assemblies are available for the splitter compartment. Use the following procedure to remove and replace a damaged adapter assembly:

1. Unlatch and fully open the cabinet swing frame to provide access to the both the front and rear side of the splitter compartment.
2. Remove the splitter or the dust cap assembly from the front side of the broken adapter assembly.



Warning: Infrared radiation is invisible and can seriously damage the retina of the eye. Do not look into the ends of any optical fiber. Do not look directly into the optical adapters or connectors. Exposure to invisible laser radiation may result. An optical power meter should be used to verify active fibers. A protective cap or hood **MUST** be immediately placed over any radiating adapter or optical connector to avoid the potential of dangerous amounts of radiation exposure. This practice also prevents dirt particles from entering the adapter or connector.

3. Remove the feeder cable connector(s) from the rear side of the broken adapter assembly as shown in [Figure 80](#) and install a dust cap on the connector(s).
4. Turn the thumb screw on the top of the broken adapter assembly clockwise until the adapter assembly detaches from the top of the splitter compartment.
5. Discard the damaged adapter assembly.

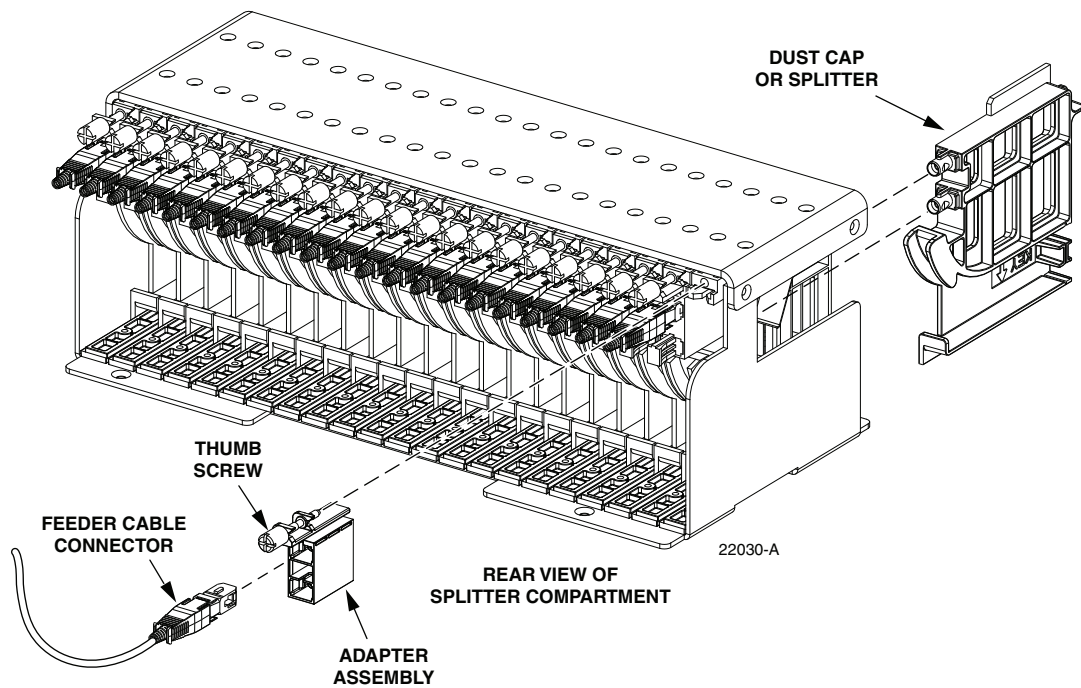

Figure 80. Splitter Compartment Adapter Replacement

6. Install the replacement adapter assembly in the splitter compartment and secure it by turning the thumbscrew counter-clockwise until tight.
7. Clean the feeder cable connector(s) as specified in the Optical Fiber Systems Cleaning and Mating Instructions (ADCP-90-159).
8. Connect the feeder cable connector to the rear side of the replacement adapter assembly.
9. Connect the dust cap or splitter to the front side of the replacement adapter assembly.
10. Close the cabinet swing frame.

15.4 Replacing a Damaged Fiber or Connector

A damaged fiber or connector can usually be replaced. The following describes the various replacement options.

- **Damaged Splitter Output Fiber:** Replace the splitter output fiber from the connector all the way back into the splitter. Splice a new pigtail (use only pigtails with reduced bend radius fiber) to the remaining section of the old fiber within the splitter chassis. This procedure requires removing and disassembling the splitter to insert a splice chip and to perform the splice. A kit is available from ADC. Refer to ADCP-96-034 for the procedure.
- **Damaged Distribution or Feeder Connector:** Replace the connector at the bulkhead adapter if just the connector alone is damaged. Use a field-installable connector replacement kit. Refer to [Section 15.4.1](#) for the replacement procedures.

15.4.1 Splitter Output Fiber Connector Replacement

Use the following procedure to replace the connector:

1. Disconnect the damaged connector and the good connector from the adapter and install a dust cap on the good connector.



Warning: *Infrared radiation is invisible and can seriously damage the retina of the eye. Do not look into the ends of any optical fiber. Do not look directly into the optical adapters or connectors. Exposure to invisible laser radiation may result. An optical power meter should be used to verify active fibers. A protective cap or hood MUST be immediately placed over any radiating adapter or optical connector to avoid the potential of dangerous amounts of radiation exposure. This practice also prevents dirt particles from entering the adapter or connector.*

2. Replace the damaged connector as specified in the procedures provided with the field-installable connector replacement kit.
3. Clean both connectors as specified in the Optical Fiber Connector Wet and Dry Cleaning Instructions (ADCP-90-159) or by locally approved procedures.
4. Reconnect the good connector and the replacement connector to the adapter.

15.5 Door Gasket Replacement

Damaged door gaskets may be replaced using the door gasket kit which includes a roll of gasket material. The ideal installation temperature for the adhesive used on the replacement gaskets is between 60 and 100 °F (16 and 38 °C). Installation is not recommended if the temperature is below 50 °F (10 °C). Remove any damaged sections of gasket material from the door. If necessary, use a citrus based adhesive cleaner to remove any adhesive that may stay attached to the door. Cut replacement lengths of gasket material from the roll as needed. Remove the paper backing to expose the adhesive and then carefully apply the replacement gasket to the door. Take care not to leave any gaps between the meeting sections of the gasket strips.

15.6 Door Replacement

Damaged cabinet doors may be replaced using the door replacement kit. Use the following procedure to remove and replace the cabinet doors:

1. Open both cabinet door and lock it in the open position as shown in [Figure 81](#).
2. Use a 3/8-inch nut driver and wrench to remove the locking nuts and washers that secure the door bracket slide to the bottom edge of the door as shown in [Figure 82](#). Save the nuts and washers for reuse.
3. Use a 3/8-inch nut driver to remove the locking nuts that secure the hinges to the door. Save nuts for reuse.

► **Note:** Support the door as the last nuts are removed to prevent the door from falling.

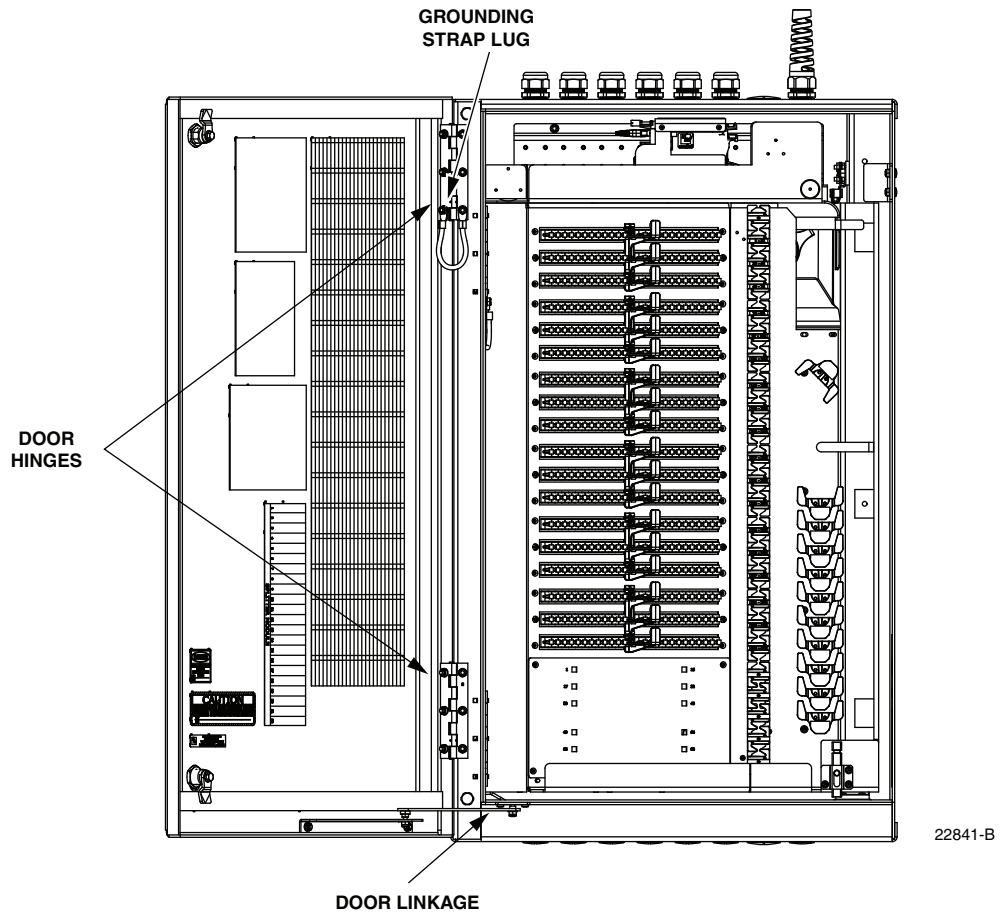

Figure 81. Door Replacement

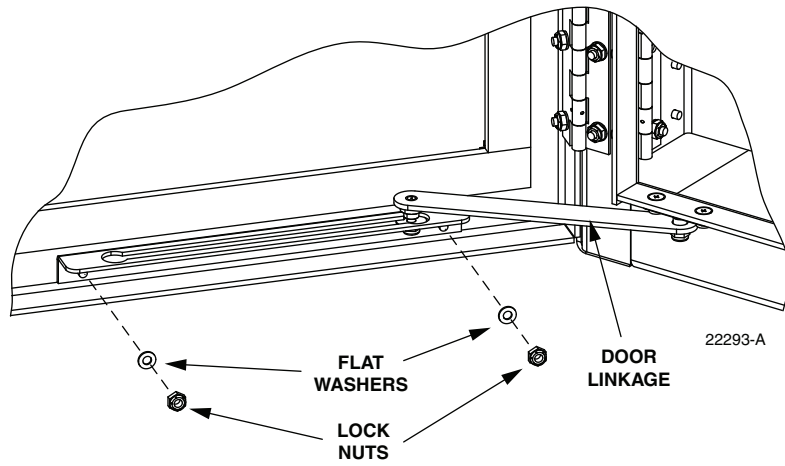

Figure 82. Door Linkage Hardware

4. Carefully lift the door away from the cabinet.
5. Transfer all designation information that may be recorded on the damaged door to the labels on the replacement door.
6. Place the replacement door in position for installation on the hinges.
7. Reinstall the locking nuts (saved in step 3) that secure each hinge to the door.
- ▶ **Note:** Be sure to re-secure the grounding strap lug (see [Figure 81](#)) to the door when securing the hinges to the door.
8. Secure the door bracket slide to the bottom edge of the door using the locking nuts and washers saved in step 2.
9. Close door and check for proper operation.

16 CUSTOMER INFORMATION AND ASSISTANCE



PHONE:

U.S.A. or CANADA

Sales:1-800-366-3891
 Extension 73000
 Technical Assistance: 1-800-366-3891
 Connectivity Extension:73475
 Wireless Extension: 73476

EUROPE

Sales Administration:+32-2-712-65 00
 Technical Assistance:+32-2-712-65 42

EUROPEAN TOLL FREE NUMBERS

Germany: 0180 2232923
 UK: 0800 960236
 Spain: 900 983291
 France: 0800 914032
 Italy: 0800 782374

ASIA/PACIFIC

Sales Administration:+65-6294-9948
 Technical Assistance:+65-6393-0739

ELSEWHERE

Sales Administration:+1-952-917-3000
 Technical Assistance:+1-952-917-3475

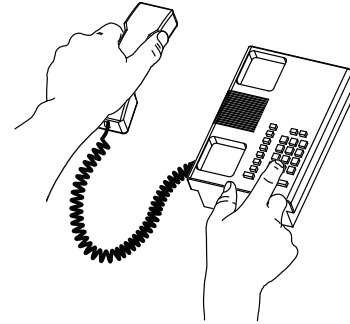

13944-Q

WRITE:

ADC Telecommunications (S'PORE) PTE, LTD;
100 Beach Road, #18-01, Shaw Towers.
Singapore 189702.

ADC Telecommunications, INC
PO Box 1101,
Minneapolis, MN 55440-1101, USA

ADC European Customer Service, INC
Belgicastraat 2,
1930 Zaventem, Belgium

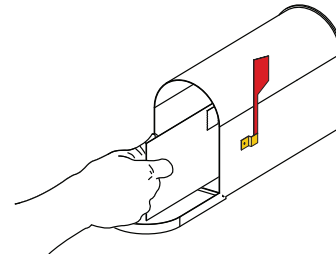

PRODUCT INFORMATION AND TECHNICAL ASSISTANCE:

connectivity.tac@adc.com

wireless.tac@adc.com

euro.tac@adc.com

asiapacific.tac@adc.com

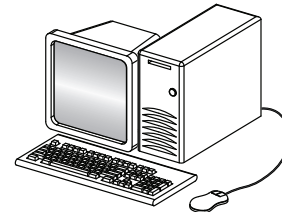

REPRINTS:

PDF copies of manuals are available
 for downloading at the following link:

www.adc.com/manuals

ADCP Number:

Contents herein are current as of the date of publication. ADC reserves the right to change the contents without prior notice. **In no event shall ADC be liable for any damages resulting from loss of data, loss of use, or loss of profits and ADC further disclaims any and all liability for indirect, incidental, special, consequential or other similar damages. This disclaimer of liability applies to all products, publications and services during and after the warranty period.**



Website: www.adc.com