

- 1.0 GENERAL NOTES
  - 1.1 ALL METRIC DIMENSIONS ARE IN BRACKETS [X.X]
  - 1.2 FEATURES CRITICAL TO QUALITY ARE INDICATED IN ROUNDED BOX (XX)
  - 1.3 3D DIGITAL FILES ARE FOR REFERENCE. IN CASE OF CONFLICT FOLLOW PDF DRAWING.
- 2.0 DESIGN NOTES
- 3.0 MANUFACTURING/SPECIAL REQUIREMENTS
  - 3.1 TORQUE HARDWARE ACCORDING TO SIZE:
    - > M6: TORQUE 40.0 IN-LB OR 4.5 N-M
    - > M8: TORQUE 6.6 FT-LB OR 9.0 N-M
  - 3.2 EXTRA HARDWARE MAY BE SUPPLIED
- 4.0 TEST
- 5.0 PACKAGING
  - 5.1 PACKAGING SHALL MEET COMMSCOPE REQUIREMENTS PER DOCUMENT IS-PL-3005
  - 5.2 ALL HARDWARE SHALL BE PACKAGED SEPARATELY USING PLASTIC BAGS
  - 5.3 THIS PRINTED DOCUMENT TO BE PLACED INSIDE SHIPPING BOX FOR CUSTOMER REFERENCE
  - 5.4 BOX SIZE SHALL NOT BE LESS THAN 14.8" X 14.8" X 3"
  - 5.5 TO BE PACKAGED AND SHIPPED SEPARATELY. SHOWN ASSEMBLED FOR REFERENCE ONLY.

REVISIONS			
REV.	DESCRIPTION	DATE	APPROVED
A	INITIAL RELEASE	MS1288 02FEB24	JX1002 40188264CMO
B	100534-331(ITEM 8 ) WAS 100117-4(ITEM 8 ) ; ADDED 100521-25(ITEM 9) & 100522-25(ITEM 10)	MS1288 01MAR24	JX1002 40188264CMO
C	BX7(ITEM 8001) WAS BX180808(ITEM 8001)	MS1288 12JUN24	JX1002 40197868CMO

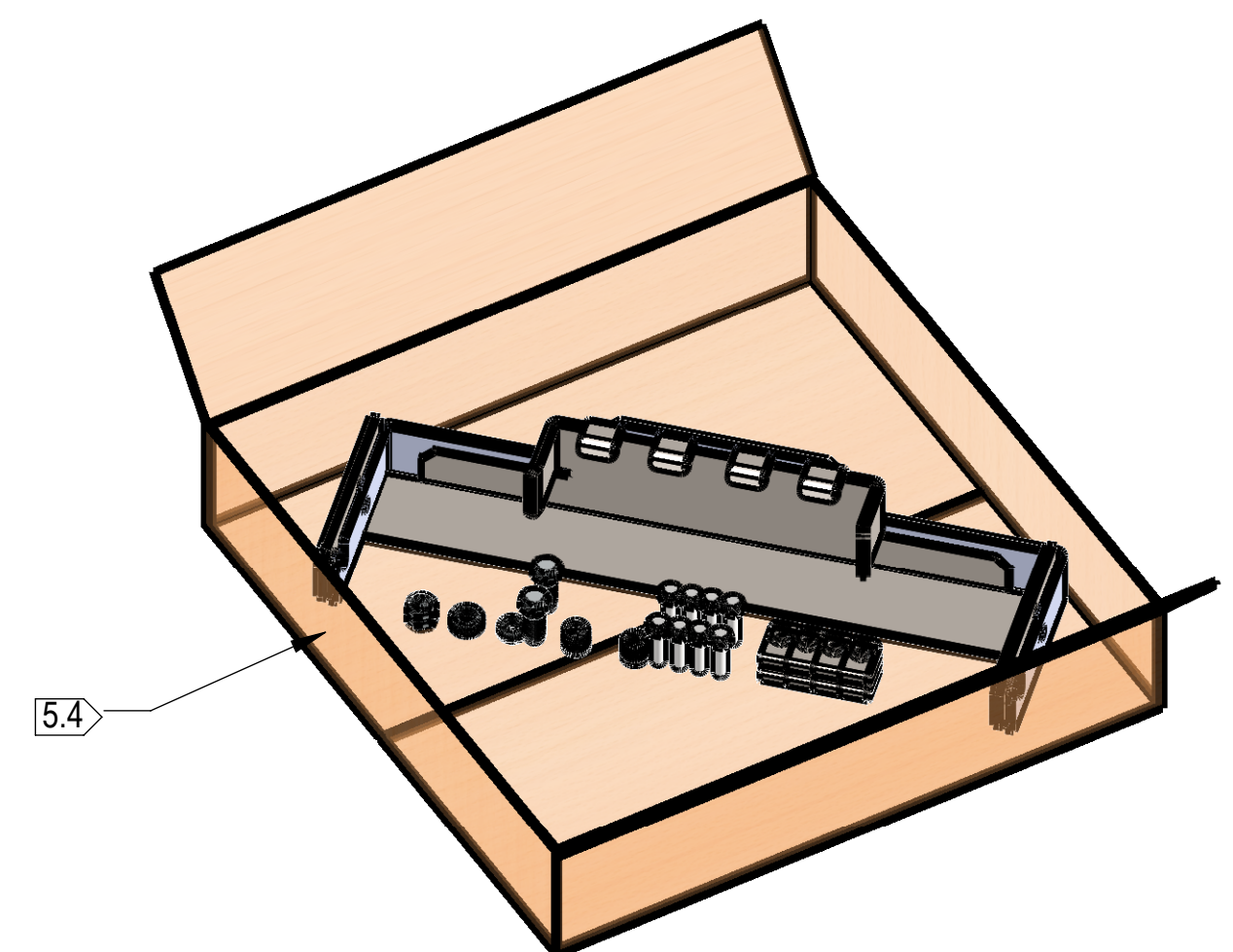
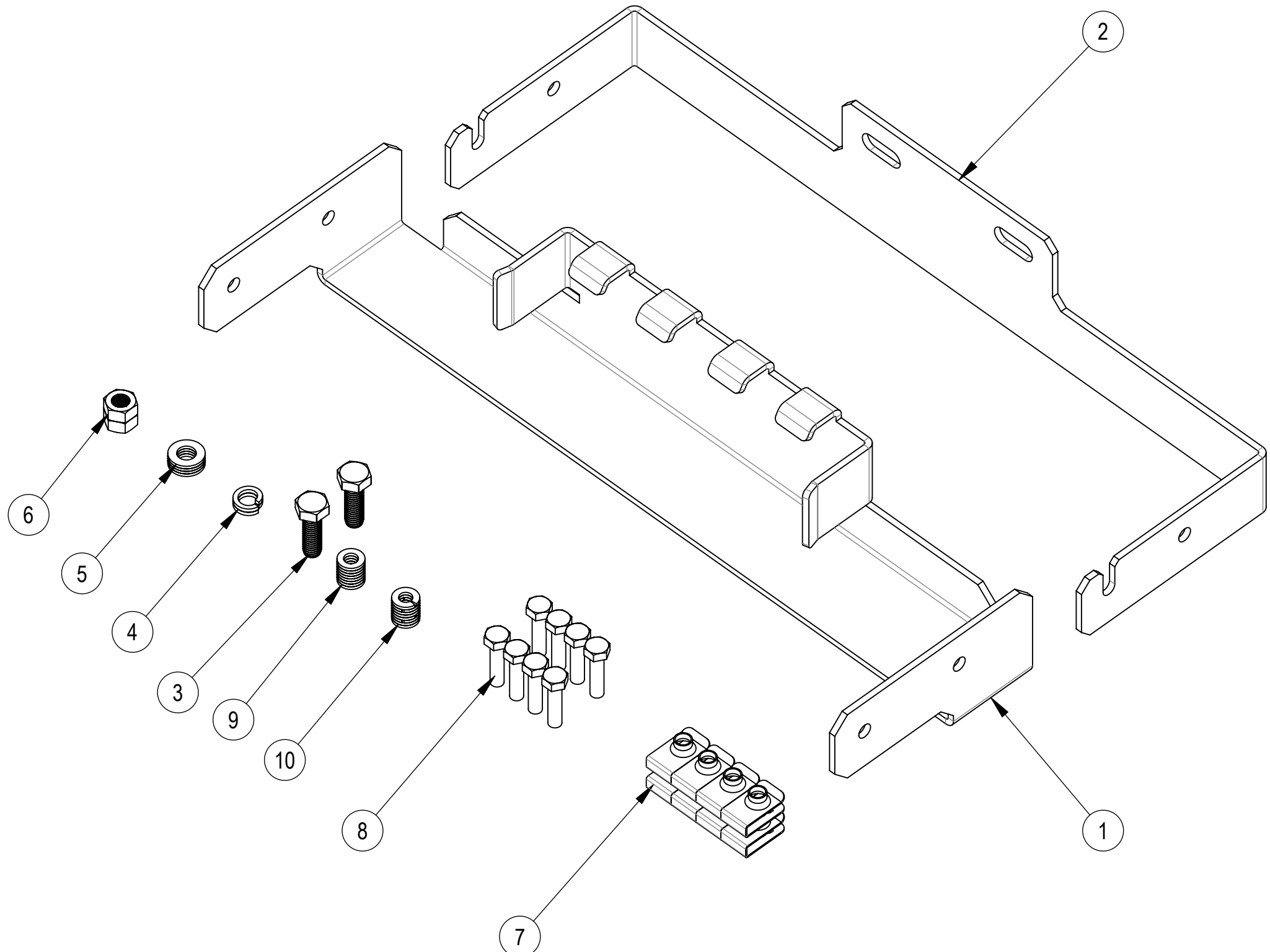

COMPONENT PART NUMBERS PROVIDED FOR ASSEMBLY PURPOSES;  
INDIVIDUAL COMPONENTS MAY BE SHIPPED AS PARTS WITHIN AN INCLUDED KIT.

ITEM NO.	PART NUMBER	DESCRIPTION	QTY.	NOTE
1	MTM1205-1000-00	BRKT, TOP,CAP H	1	
2	MTM1205-2000-00	BRKT, BOTTOM,CAP H	1	
3	MTC9415	M8 X 25mm HEX BOLT SS	2	5.2
4	MTC9418	M8 LOCK WASHER SS	2	5.2
5	MTC9419	M8 FLAT WASHER SS	4	5.2
6	MTC9417	M8 HEX NUT SS	2	5.2
7	460143456	CLIP NUT, M6, 316 SST	8	5.2
8	100534-331	SCR,HCS,HEX,M6X25,SST,PASS	8	5.2
9	100521-25	WSHR,FLAT,M6,6.4X12X1.6,SST,PASS	8	5.2
10	100522-25	WSHR,LK,SPLT, M6,SST, PASS	8	5.2
9000	MTM1193-1101-AMK-H	KIT CAP-H INSTALL INTO PB20GA-0.375	1	5.3

<b>COMMSCOPE, INC. OF NORTH CAROLINA</b>									
TOLERANCES					SAP MATERIAL MASTER				
1 PLACE .X[X] ± 0.2[6.3]			3 PLACE .XXX[X] ± 0.060[1.5]		<b>MTM1193-1101-AMK-H</b>				
2 PLACE .XX[X] ± 0.12[3.0]			ANGLES ± 2°						
FINISH					MATERIAL				
UNLESS OTHERWISE SPECIFIED DIMENSIONS ARE IN INCHES INTERPRET PER ANSI Y 14.5M-1994	CE	MS1288	02FEB24	<b>KIT CAP-H INSTALL INTO PB20GA-0.375</b>					
	RW	MS1288	06/12/2024						
	AD	JX1002	06/12/2024						
	RE	DM1121	06/12/2024						
	ECN	40197868CMO							
SCALE <b>1:4</b>		DOCUMENT NO. <b>MTM1193-1101-AMK-H</b>							
SIZE	Auth Group	INSL	MODEL			DRAWING			SHEET
<b>C</b>			VERSION	STATUS	REVISION	VERSION	STATUS	REVISION	1 OF 5
			02	RE	C	02	RE	C	

DENSITY		lbs/in³
MASS	5.00	lbs
VOLUME	720.00	in³
SURFACE AREA	1335.00	in²
HEIGHT	3.2[81.28]	
LENGTH	15.00[381.0]	
WIDTH	15.00[381.0]	

# MTM1193-1101-AMK-H INSTALLATION INSTRUCTIONS

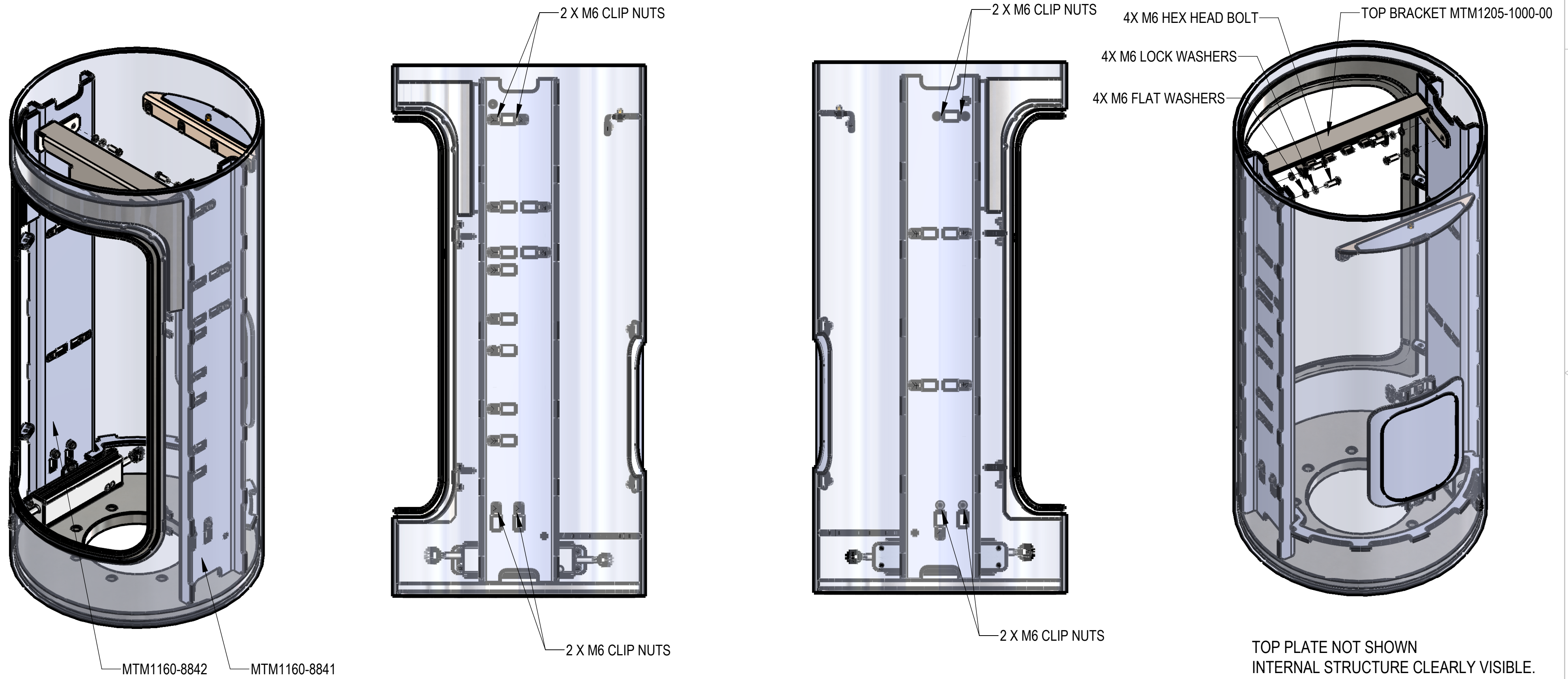

STEP 1  
 OPEN THE DOOR, INSTALL 4EA M6 CLIP NUTS TO BRACKET MTM1160-8841.  
 INSTALL 4EA M6 CLIP NUTS TO BRACKET MTM1160-8842.  
 INSTALL TOP BRACKET MTM1205-1000-00 TO MAIN FRAME USING 4 SETS OF  
 M6 HARDWARE AS SHOWN.

COMMSCOPE, INC. OF NORTH CAROLINA			
TITLE KIT CAP-H INSTALL INTO PB20GA-0.375			
SIZE <b>C</b>	SCALE <b>1:12</b>	DOCUMENT NO. MTM1193-1101-AMK-H	
DRAWING			SHEET
VERSION 02	STATUS RE	REVISION C	2 OF 5



4

3

2

1

D

D

C

C

B

B

A

A

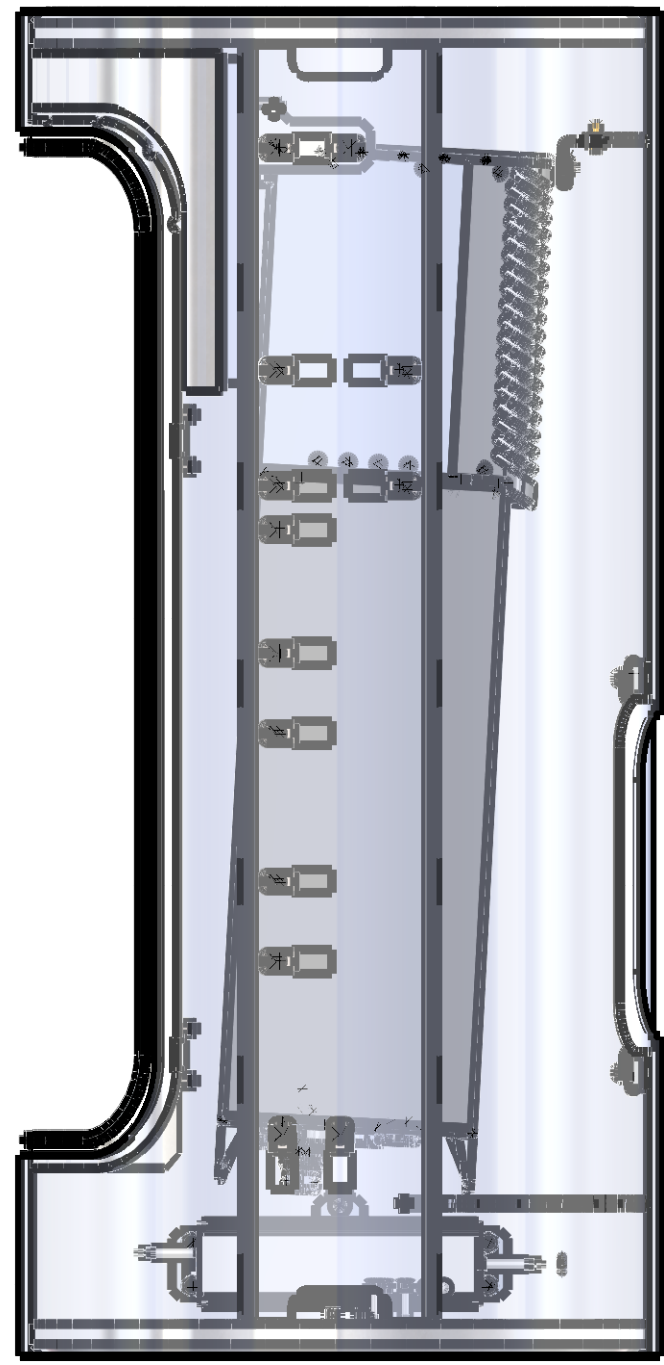
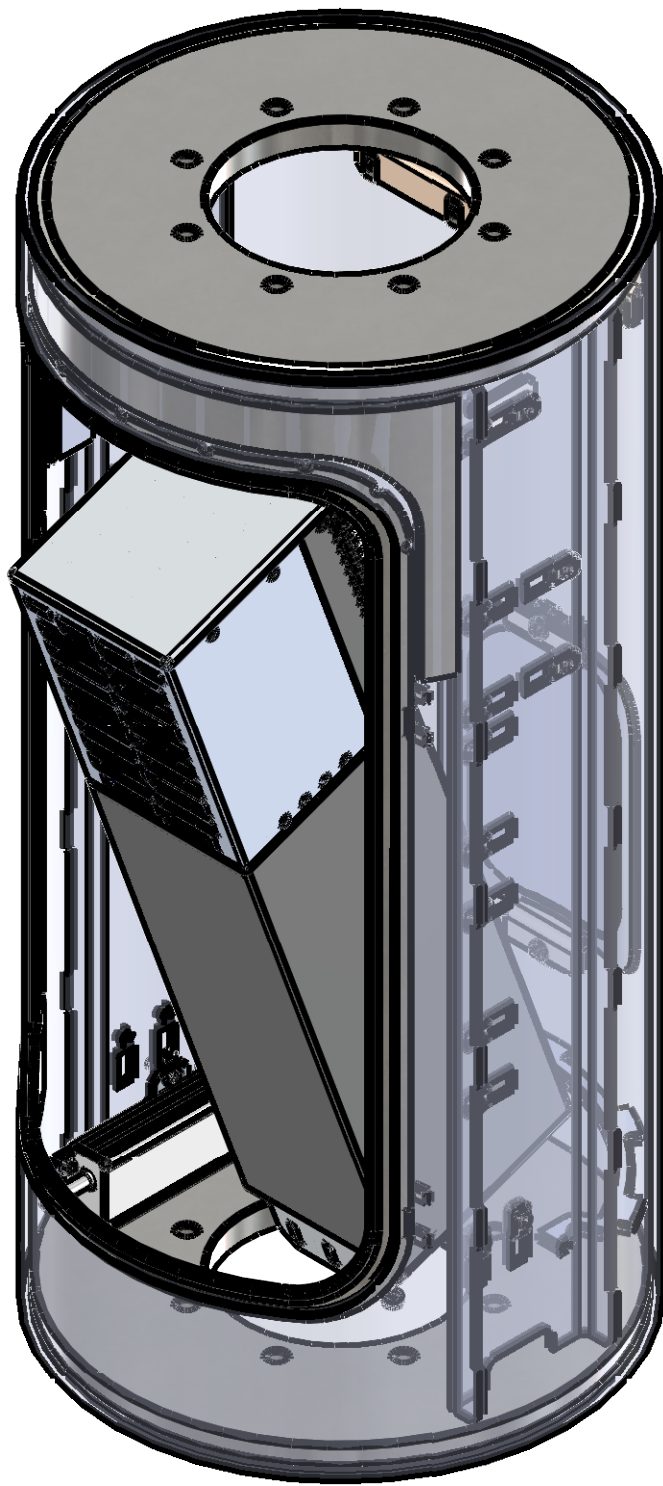
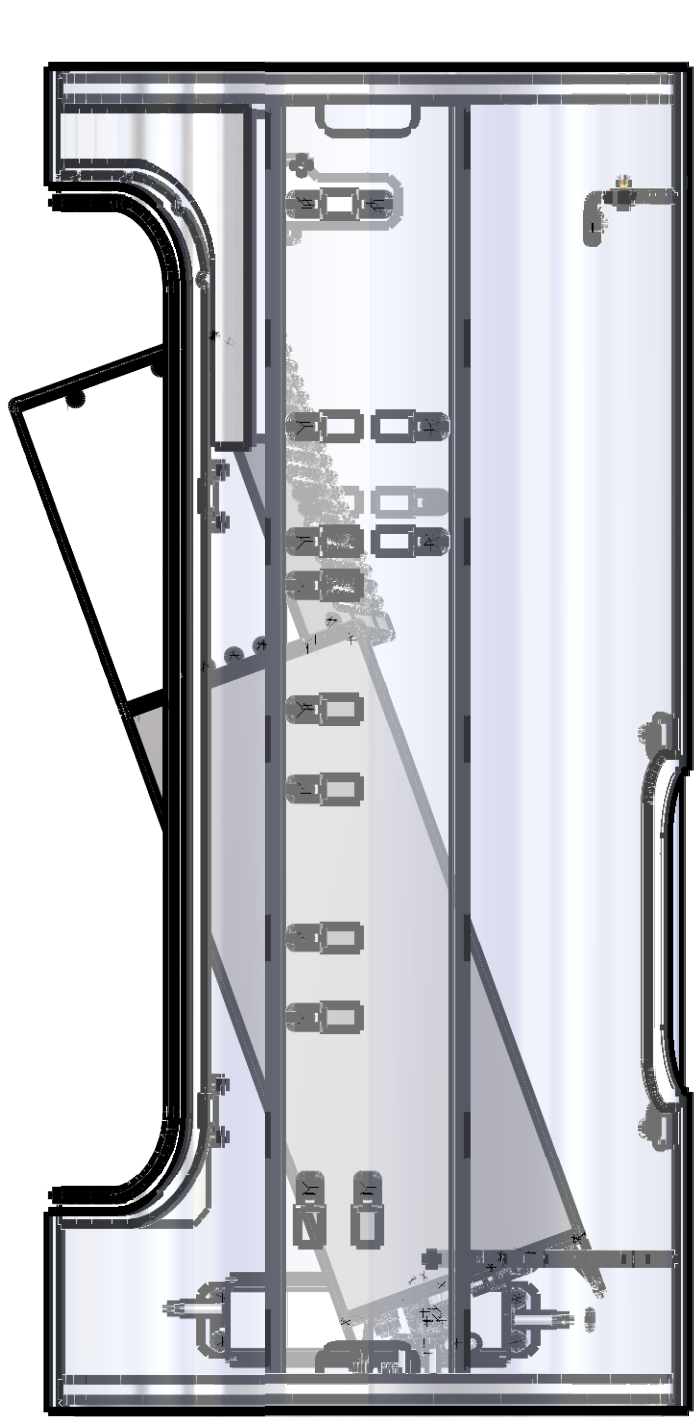

TOP BRACKET MTM1205-1000-00

GUIDE PLATE

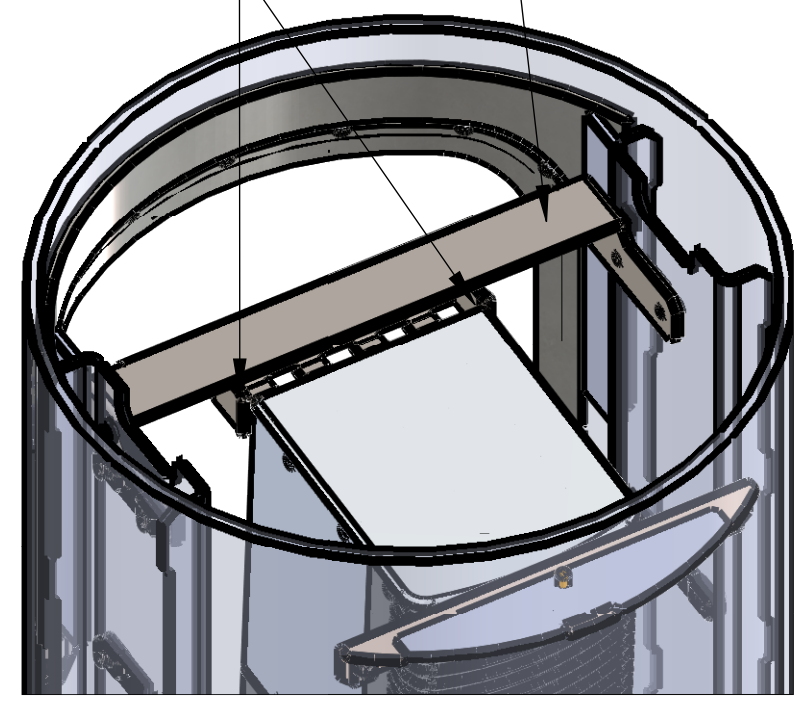

TOP PLATE NOT SHOWN  
INTERNAL STRUCTURE CLEARLY VISIBLE.

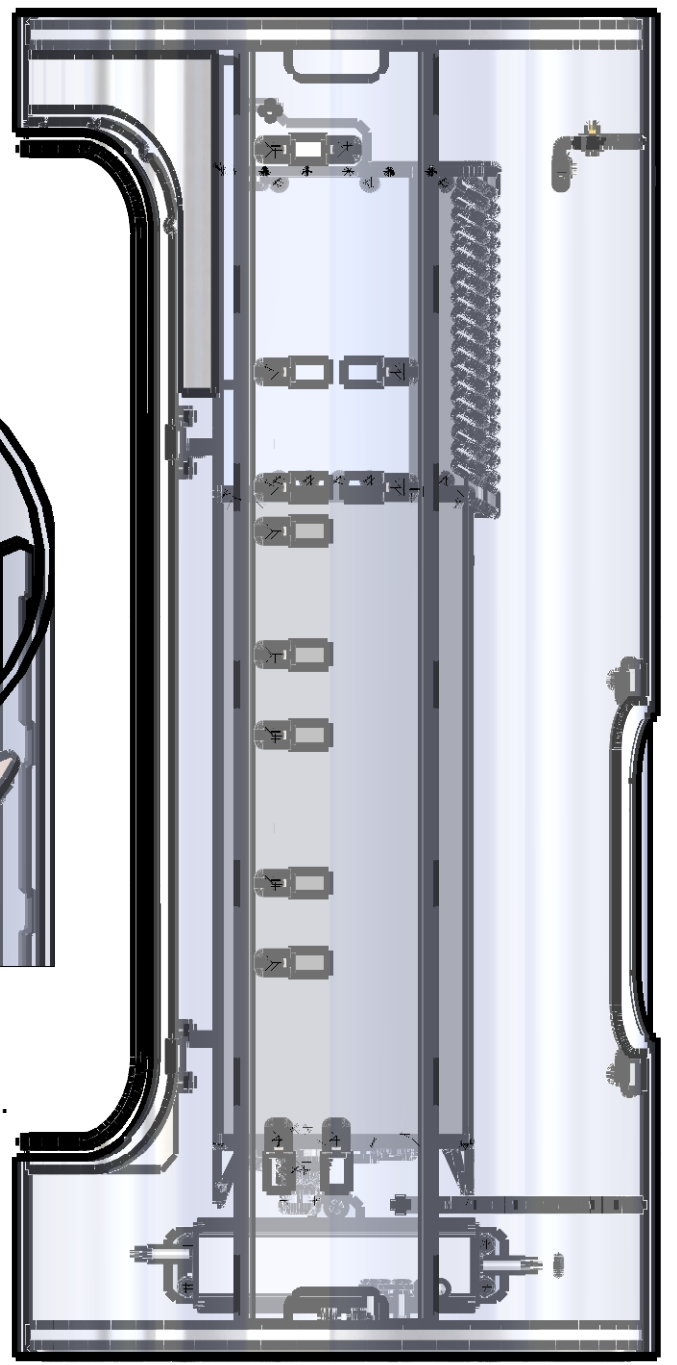

STEP 2  
 CAP H IS PLACED INTO D-MOD AT ANGLE  
 MOVE TO THE POSITION OF THE GUIDE PLATE AND HANG IT INTO HOOK

COMMSCOPE, INC. OF NORTH CAROLINA				
TITLE KIT CAP-H INSTALL INTO PB20GA-0.375				
SIZE <b>C</b>	SCALE <b>1:8</b>	DOCUMENT NO. MTM1193-1101-AMK-H		
		DRAWING		SHEET
		VERSION	STATUS	REVISION
		02	RE	C
				3 OF 5

© 2024 CommScope, Inc. Confidential

4

3

2

1

4

3

2

1

D

D

C

C

B

B

A

A

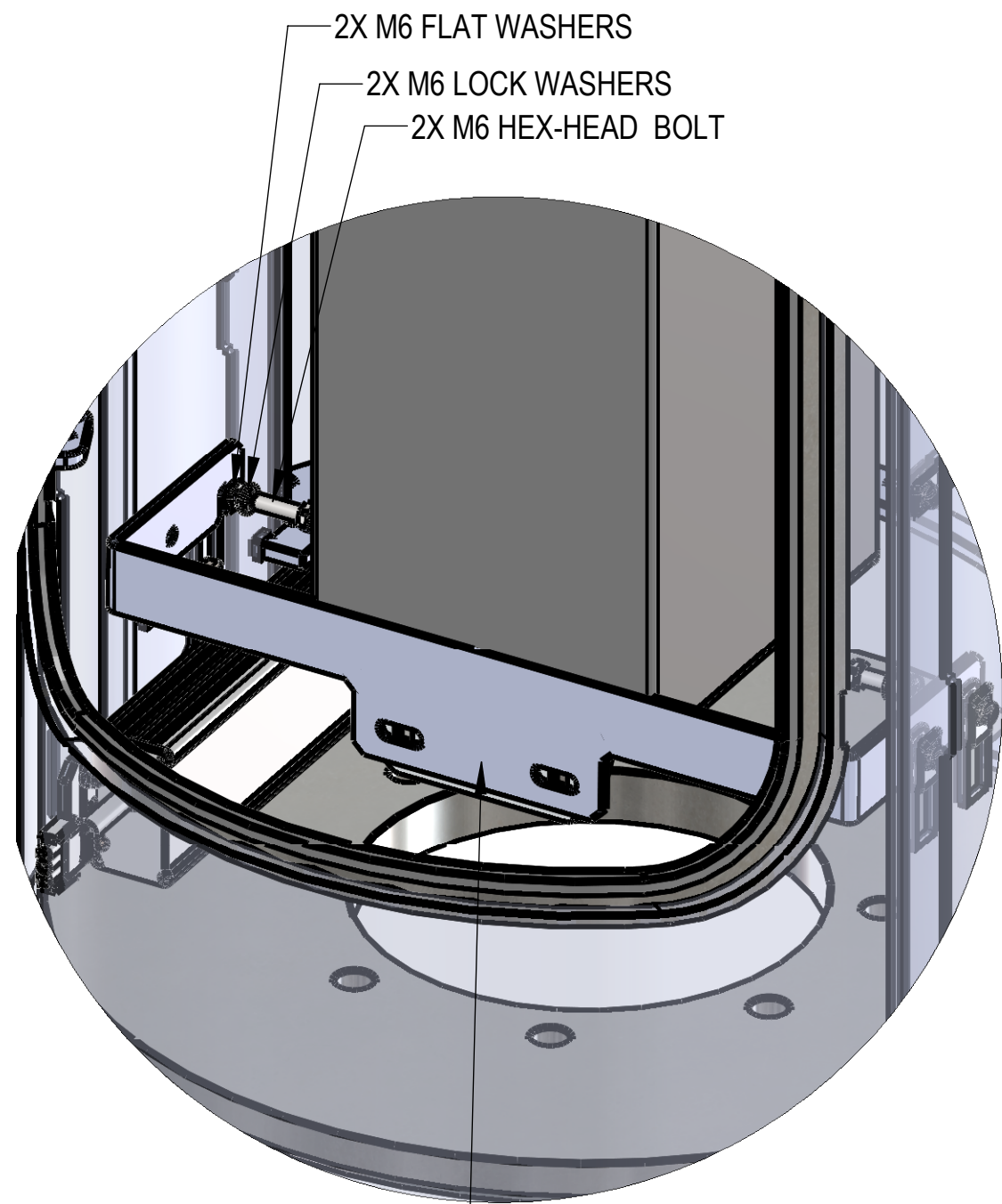
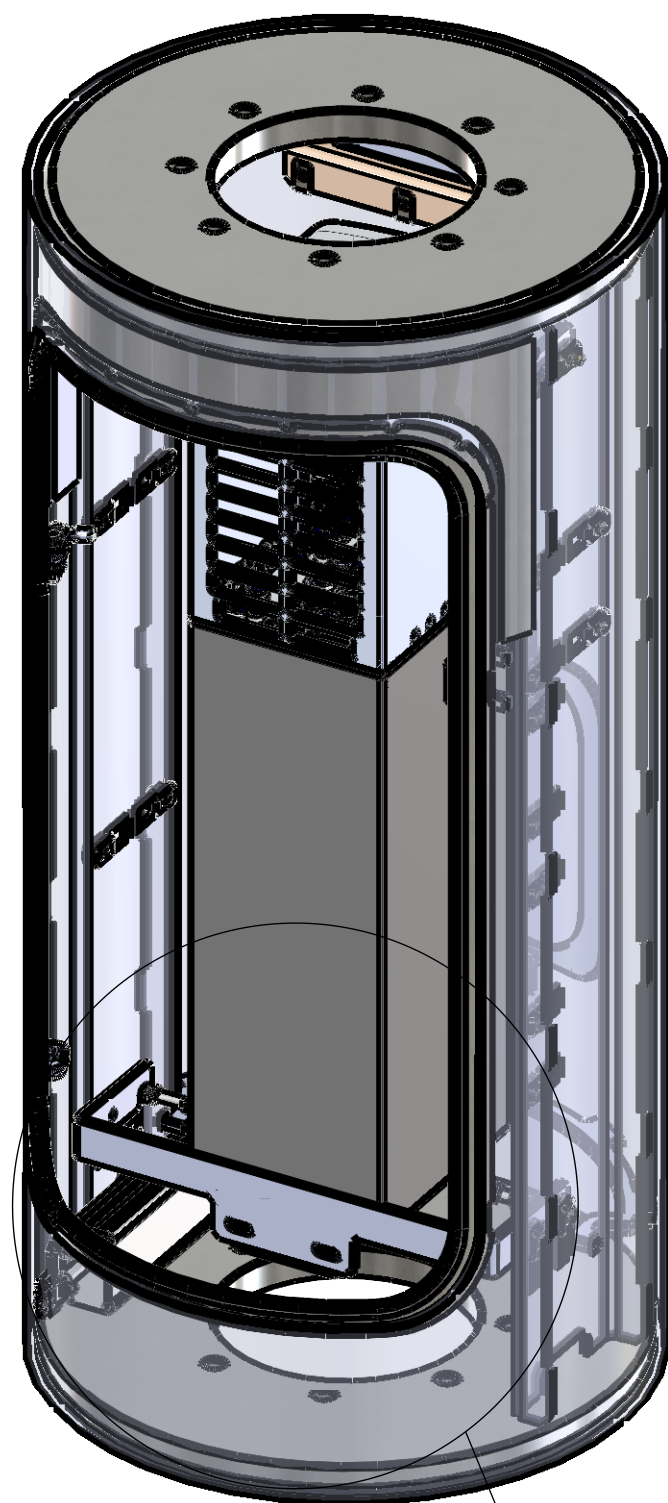

A BOTTOM BRACKET MTM1205-2000-00  
 DETAIL A  
 SCALE 1 : 3

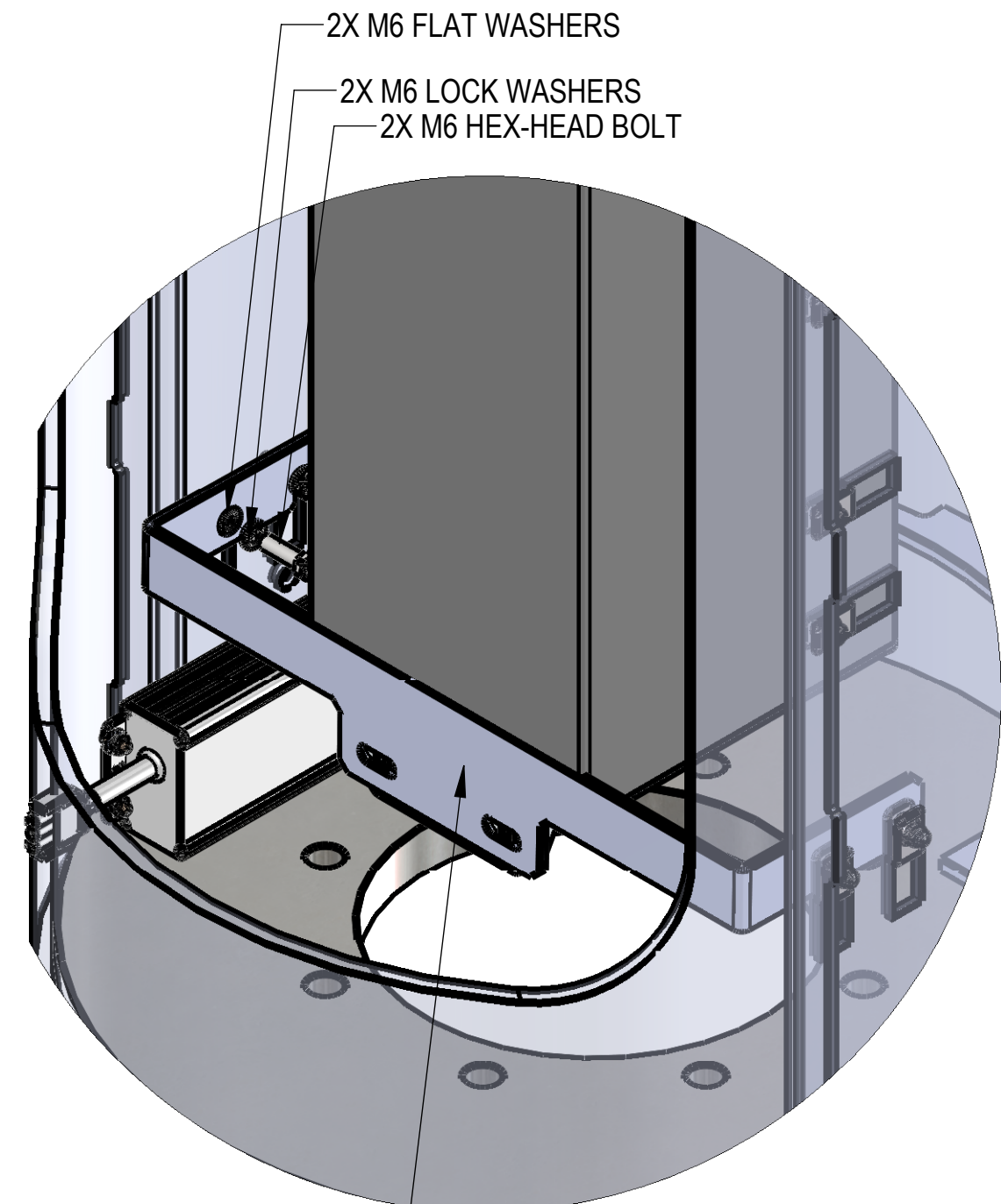
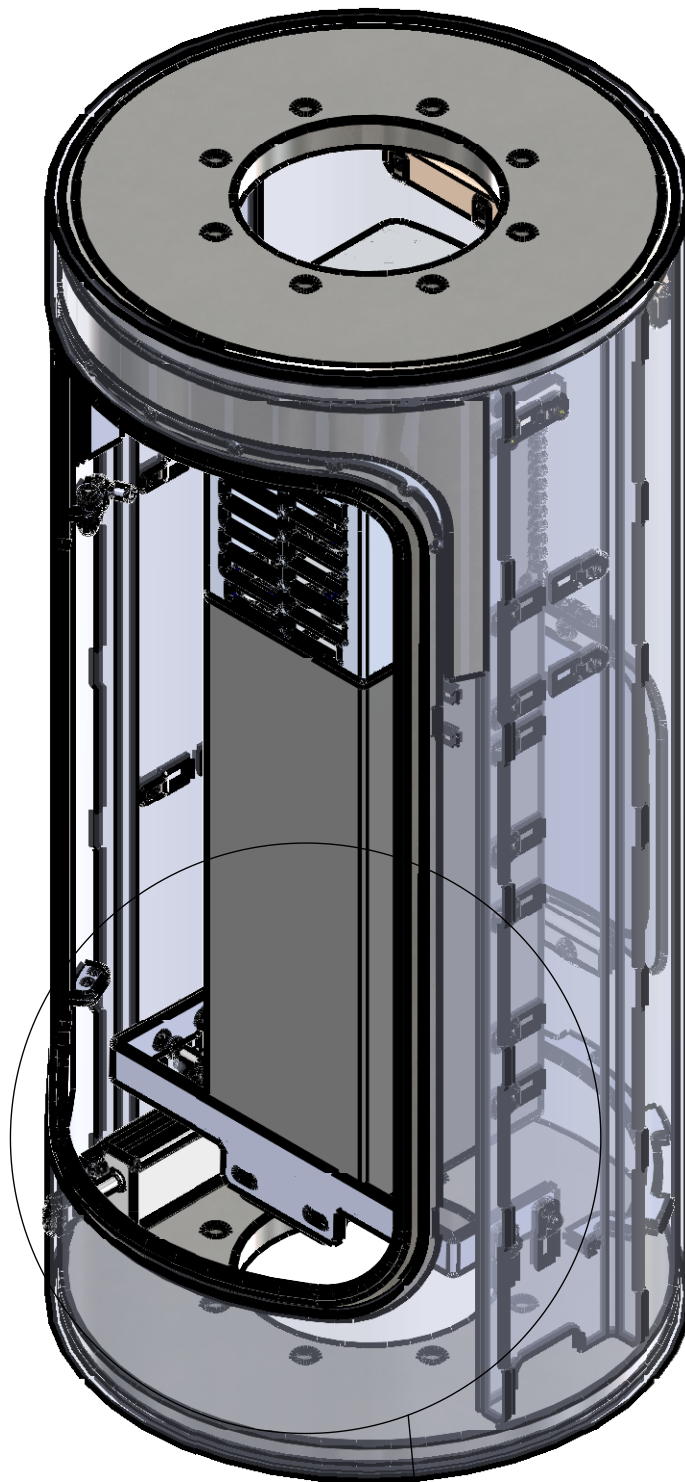

B BOTTOM BRACKET MTM1205-2000-00  
 DETAIL B  
 SCALE 1 : 3

STEP 3  
 PRE-ASSEMBLED 2 SETS OF M6 HARDWARE TO MAIN FRAME  
 THE BOTTOM BRACKET IS PLACED AS SHOWN.

STEP 4  
 FIX THE BOTTOM BRACKET USING 4 SETS OF M6 HARDWARE AS SHOWN.

COMMSCOPE, INC. OF NORTH CAROLINA					
TITLE KIT CAP-H INSTALL INTO PB20GA-0.375					
SIZE C	SCALE 1:8	DOCUMENT NO. MTM1193-1101-AMK-H			
		DRAWING			SHEET 4 OF 5
		VERSION 02	STATUS RE	REVISION C	

4

3

2

1



4

3

2

1

D

D

C

C

B

B

A

A

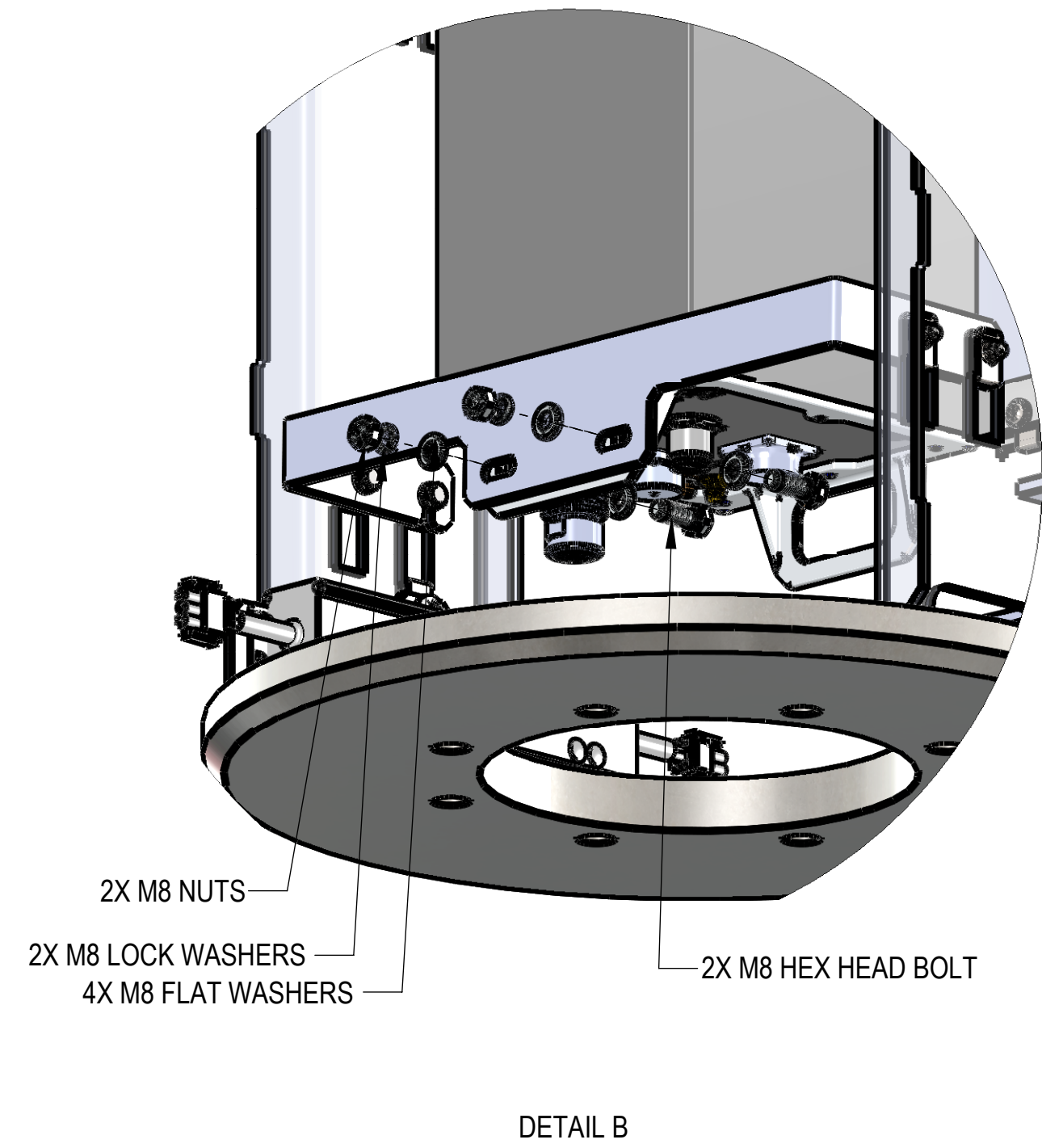
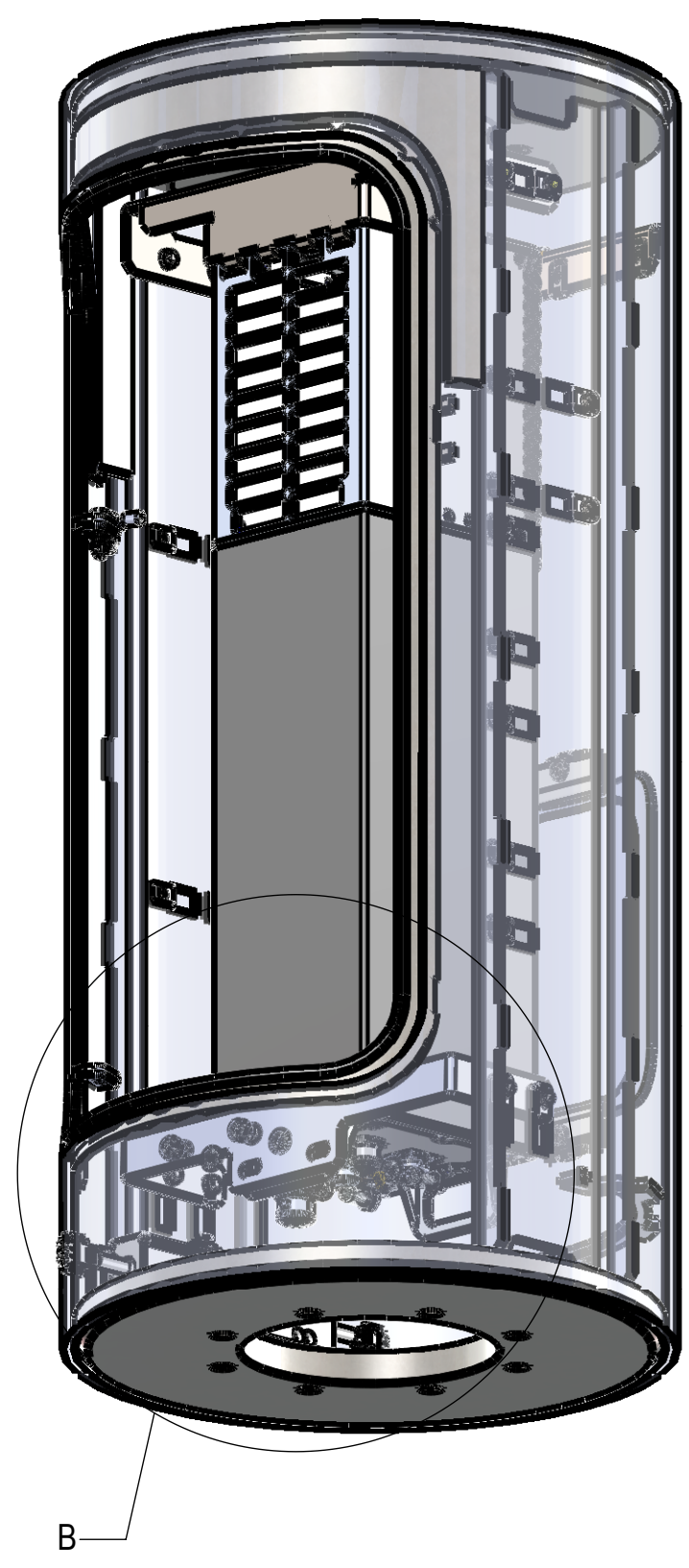

STEP 5  
FIX THE CAP H TO THE BOTTOM BRACKET MTM1205-2000-00  
USING 2 SETS OF M8 BOLTS, LOCK & FLAT WASHERS AS SHOWN.

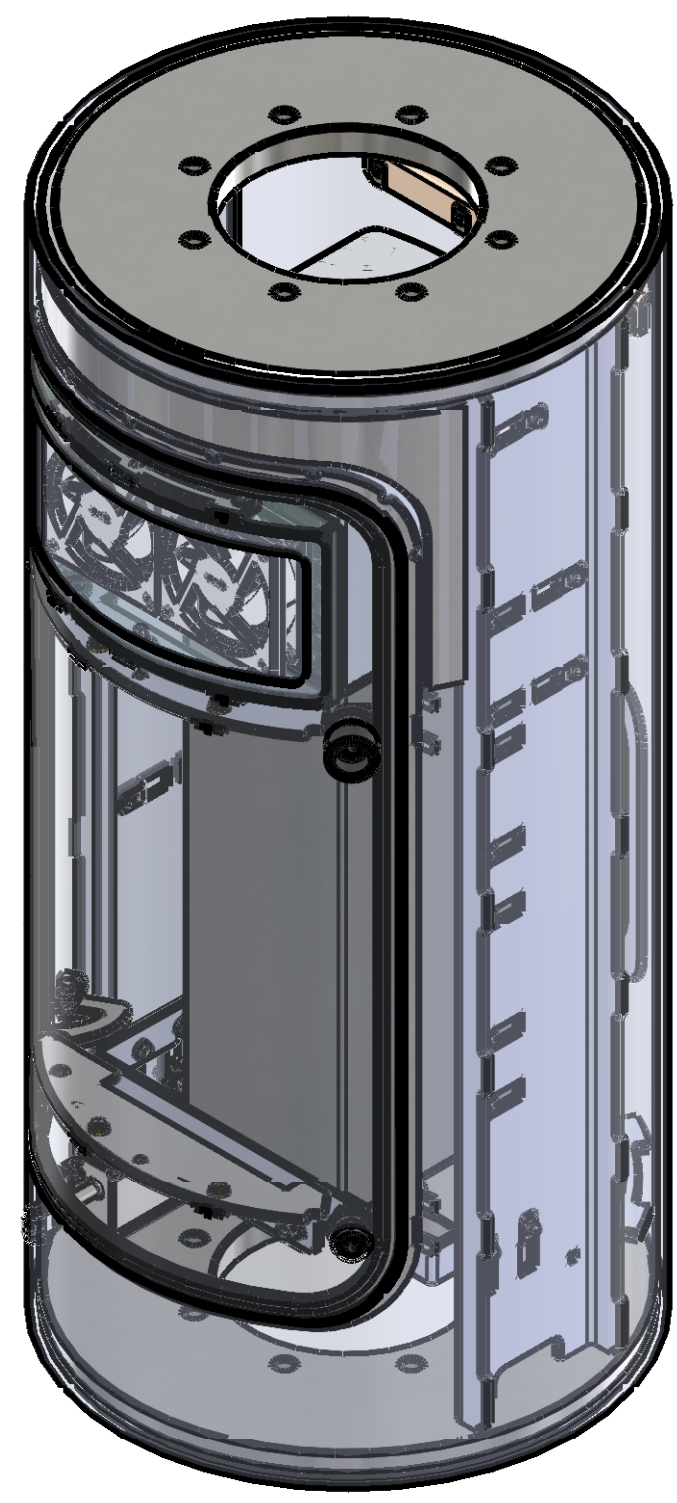

STEP 6  
CLOSE THE DOOR

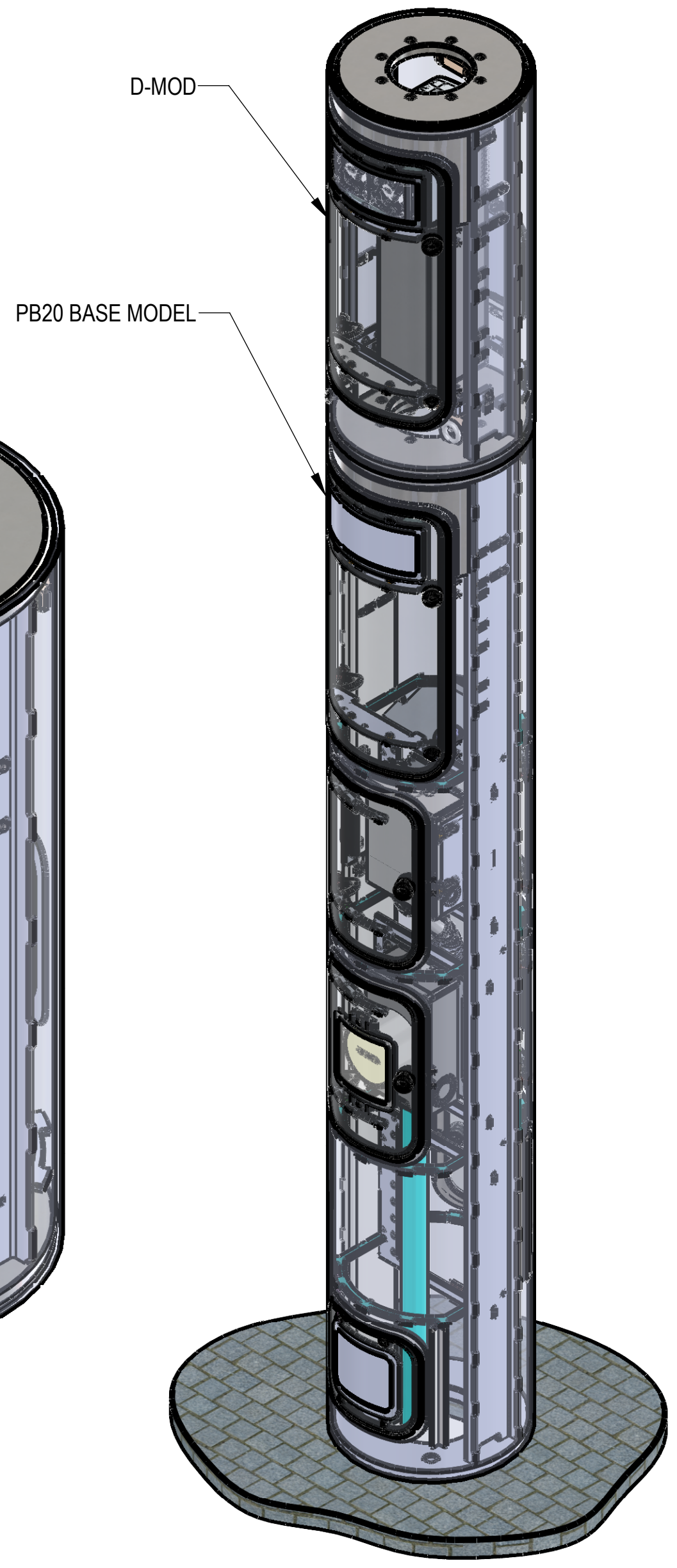

FINISHED PRODUCT

COMMSCOPE, INC. OF NORTH CAROLINA				
TITLE KIT CAP-H INSTALL INTO PB20GA-0.375				
SIZE C	SCALE 1:8	DOCUMENT NO. MTM1193-1101-AMK-H		
DRAWING		VERSION	STATUS	REVISION
		02	RE	C
				SHEET 5 OF 5

4

3

2

1

