

4

3

2

1

- 1.0 GENERAL NOTES
 - 1.1 ALL METRIC DIMENSIONS ARE IN BRACKETS [X. X]
 - 1.2 FOR PATENT INFO: <https://www.cs-pat.com>
- 2.0 DESIGN NOTES
- 3.0 MANUFACTURING/SPECIAL REQUIREMENTS
 - 3.1 TIGHTEN ALL BOLTS SECURING FLAT PLATES BY THE TURN-OF-NUT METHOD. TIGHTEN ALL U-BOLTS USING TURN-OF-NUT METHOD WITH ATTENTION TO LEAVE EQUAL DISTANCE AND EQUAL FORCE ON EACH LEG OF THE U-BOLT.
- 4.0 TEST
- 5.0 PACKAGING
 - 5.1 PACKAGING SHALL MEET COMMSCOPE REQUIREMENTS PER DOCUMENT IS-PL-3005
 - 5.2 PRINTED DOCUMENT TO BE PLACED INSIDE POLYBAG AND THEN IN SHIPPING CONTAINER
 - 5.3 EXTRA HARDWARE MAY BE SUPPLIED, BAGGED AND SHIPPED

REVISIONS			
REV.	DESCRIPTION	DATE	APPROVED
A	INITIAL RELEASE	LS1146 04JUL24	YW1045 40199608CMO

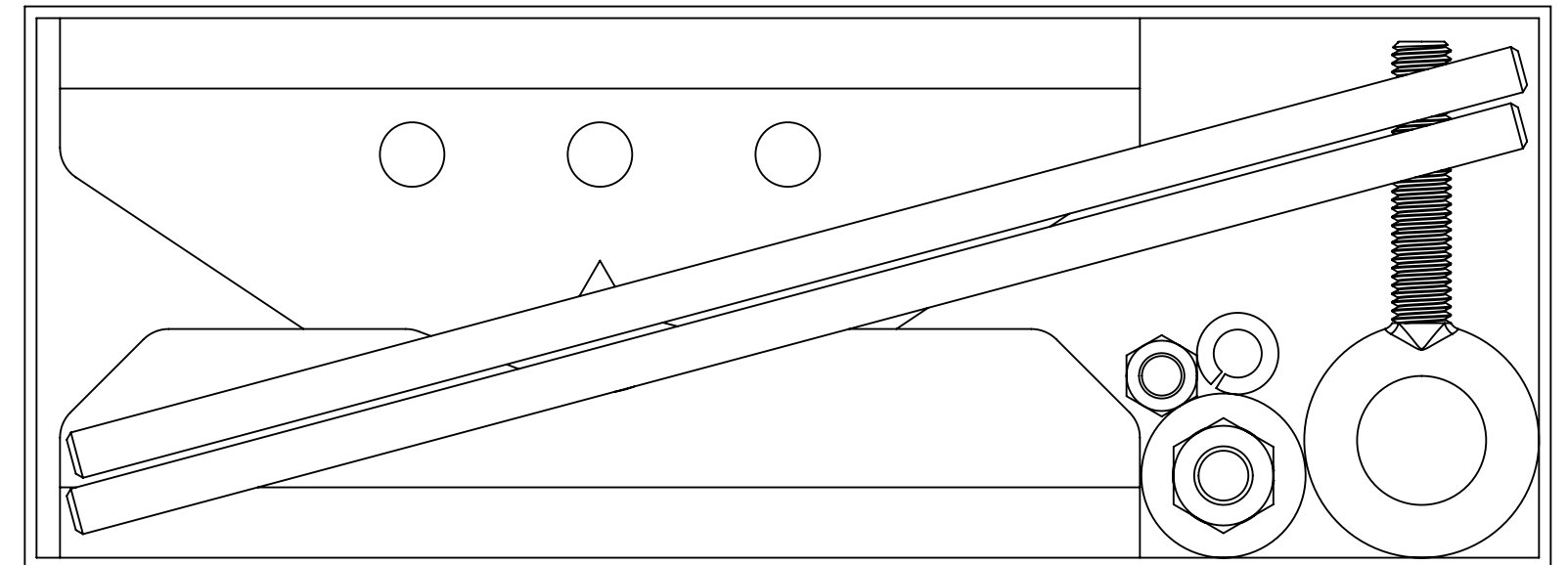
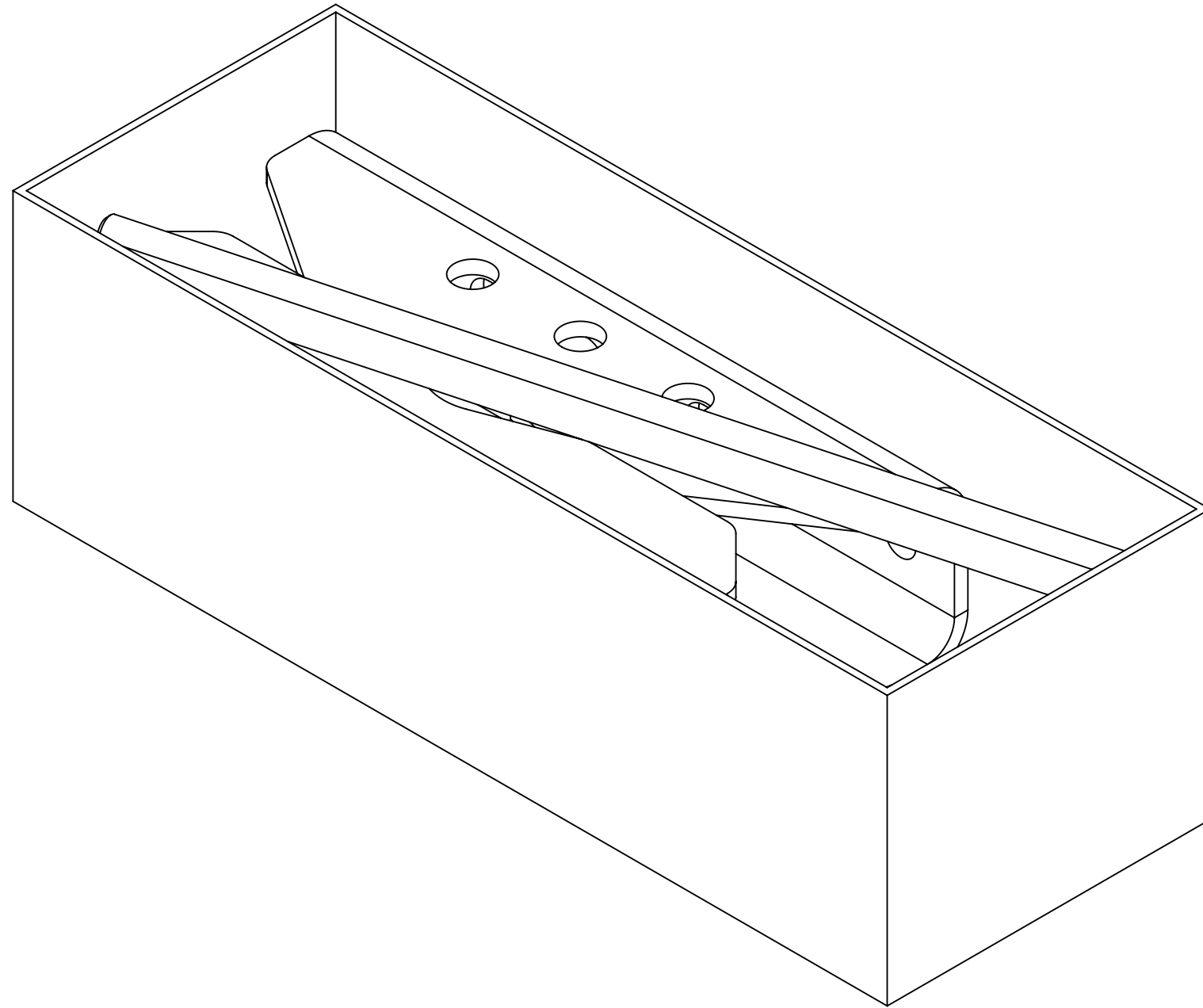

PACKAGE

NOTE : MAXIMUM CABLE WEIGHT (WITH ICE) = 3000 LBS
 ONLY ONE EYE BOLT SHOULD BE LOADED AT THE CENTER OF THE MOUNT

COMMSCOPE, INC. OF NORTH CAROLINA												
TOLERANCES						SAP MATERIAL MASTER						
1 PLACE .X[X] ± 0.25[6.3]			3 PLACE .XXX[X] ± 0.06[1.5]			860680188-006						
2 PLACE .XX[X] ± 0.12[3.0]			ANGLES ± 2°									
FINISH						MATERIAL						
UNLESS OTHERWISE SPECIFIED DIMENSIONS ARE IN INCHES INTERPRET PER ANSI Y 14.5M-1994	NAME		DATE		GRIP ANCHOR, PIPE, 1.5"-8"							
	CE LS1146		04JUL24									
	RW LS1146		07/09/2024									
	AD YW1045		07/09/2024									
	RE YMENG		03/23/2023									
ECN 40199608CMO						SCALE 1:2		DOCUMENT NO. 860680188-006				
SIZE		Auth Group		INSL		MODEL			DRAWING			SHEET 1 OF 2
C						VERSION			STATUS			
						00			AD			
						A			00			
						AD			A			

DENSITY		lbs/in³
MASS	13.54	lbs
VOLUME	50.03	in³
SURFACE AREA	446.30	in²
HEIGHT	11.50"	
LENGTH	16.00"	
WIDTH	5.66"	

4

3

2

1

4

3

2

1

NOTE : MAXIMUM CABLE WEIGHT (WITH ICE) = 3000 LBS
ONLY ONE EYE BOLT SHOULD BE LOADED AT THE CENTER OF THE MOUNT

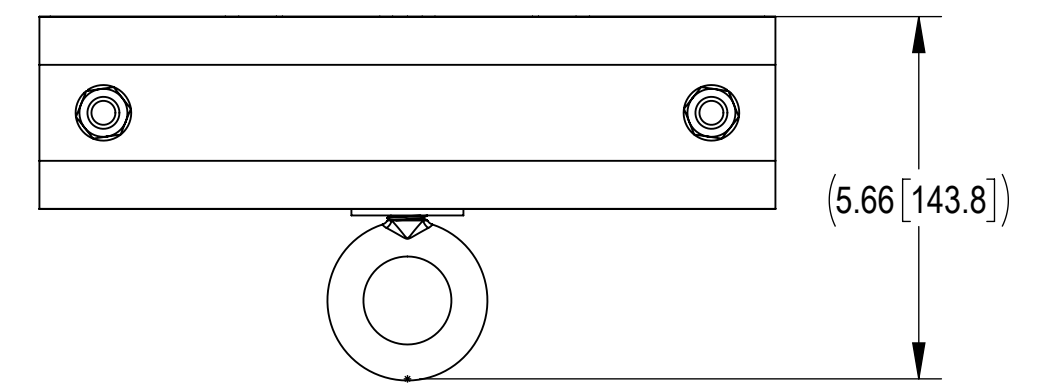
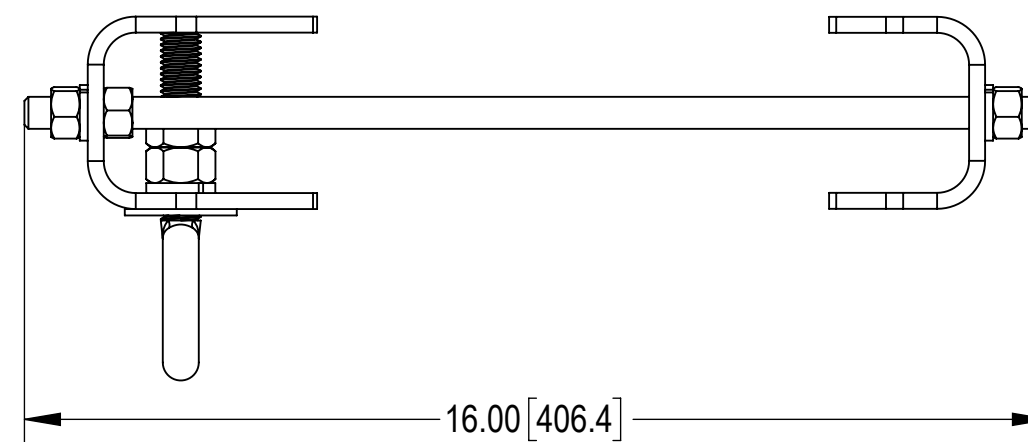
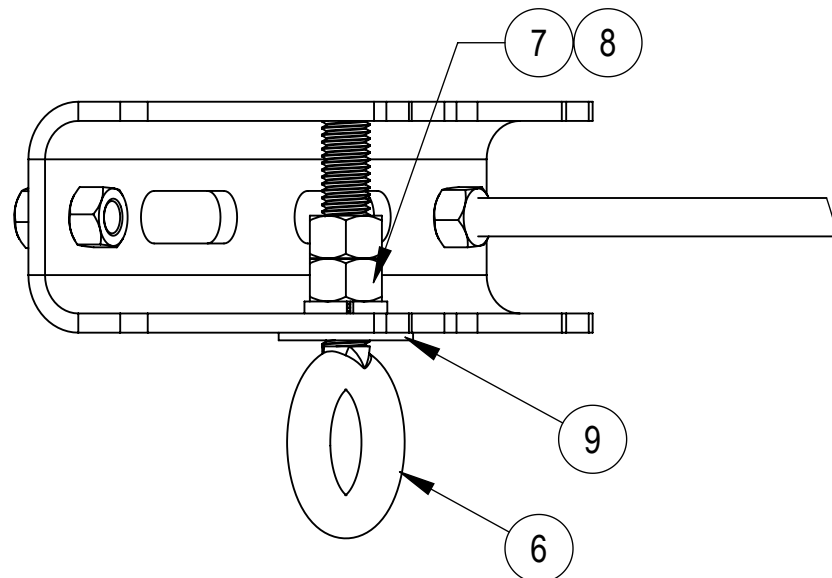
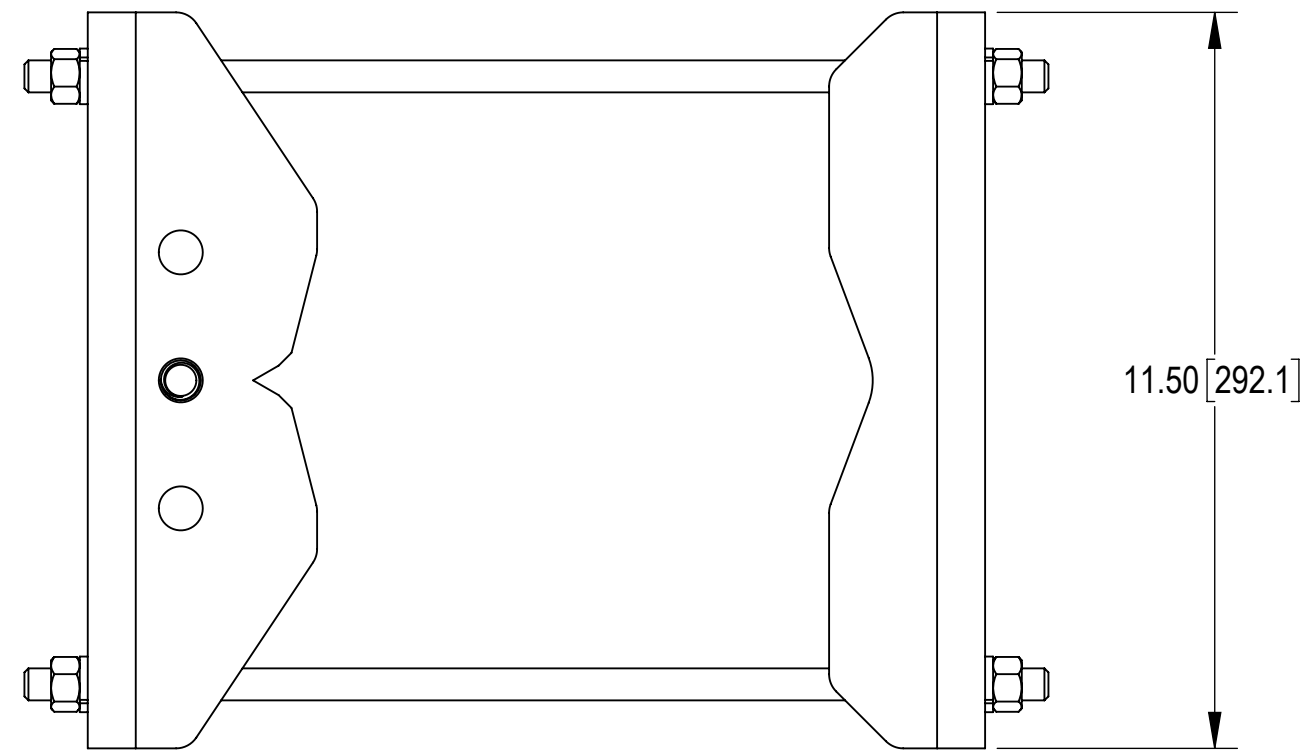
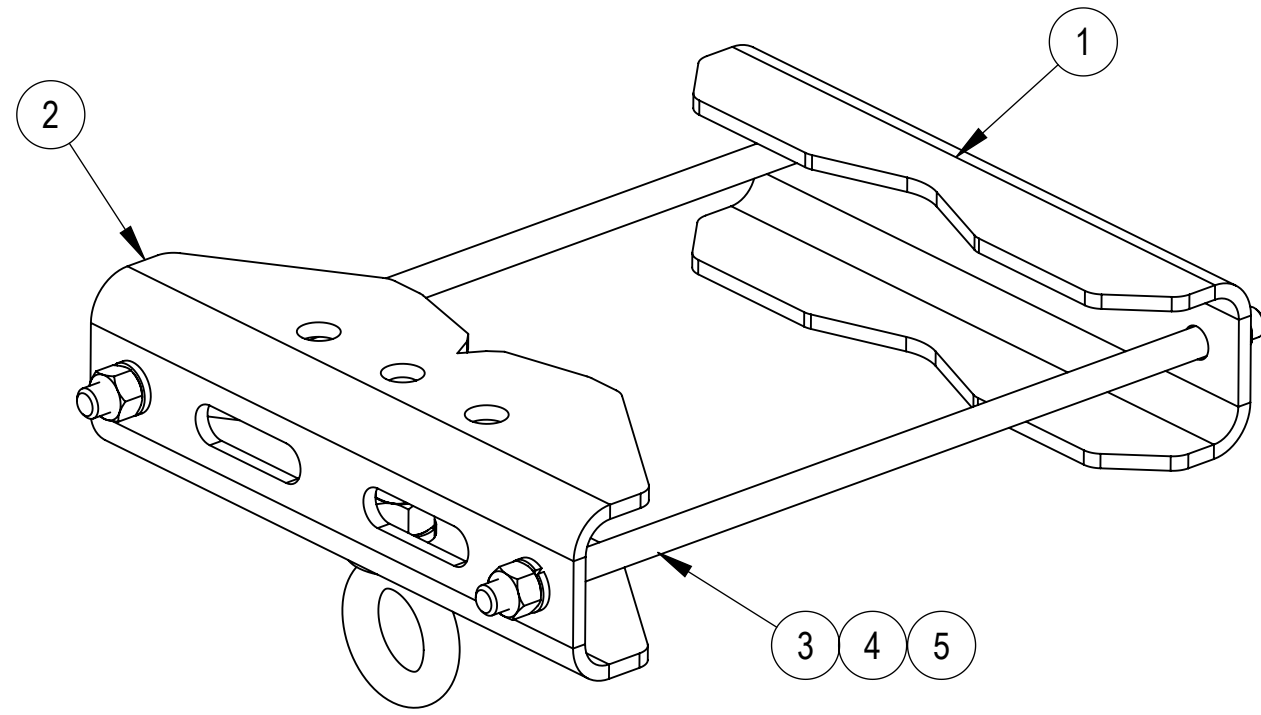

COMPONENT PART NUMBERS PROVIDED FOR ASSEMBLY PURPOSES;
INDIVIDUAL COMPONENTS MAY BE SHIPPED AS PARTS WITHIN AN INCLUDED KIT.

ITEM	PART NO.	DESCRIPTION	QTY.	WEIGHT	NOTE NO.
1	MTC397531	BACK BRACKET, SM-U2080LD	1	5.15 LBS	
2	MTC397532	FRONT BRACKET, SM-U2080LD	1	5.97 LBS	
3	MT37916	1/2" X 16" GALV THREADED ROD	2	0.88 LBS	
4	GN-04	1/2" GALV HEX NUT	6	0.04 LBS	
5	GWL-04	1/2" GALV LOCK WASHER	4	0.01 LBS	
6	9674-1	BOLT,EYE,5/8X3,STL,ZN PLD	1	2.29 LBS	
7	GN-05	5/8" GALV HEX NUT	2	0.08 LBS	
8	GWL-05	5/8" GALV LOCK WASHER	1	0.03 LBS	
9	GWF-05	GALV FLAT WASHER 5/8" (EA)	1	0.06 LBS	

COMMSCOPE, INC. OF NORTH CAROLINA				
TITLE GRIP ANCHOR, PIPE, 1.5"-8"				
SIZE C	SCALE 1:5	DOCUMENT NO. 860680188-006		
DRAWING		VERSION	STATUS	REVISION
		00	AD	A
				SHEET 2 OF 2

© 2024 CommScope, Inc. Confidential

4

3

2

1